



MV DISCONNECTORS

MV AIR CUT-OFF SWITCHES

**MV SWITCH DISCONNECTORS WITH AIR
INTERRUPTERS WITH SWITCHING CURRENT 100A**

MANUAL AND MOTOR DRIVES



CERTIFICATES AND AWARDS



Instytut Energetyki
– PAŃSTWOWY INSTYTUT BADAWCZY
Zespół ds. Certyfikacji i Inspekcji
ul. Młoty 8, 01-530 Warszawa
tel. +48 22 34 51 200
instytut.energetyki@ien.com.pl



AC 117

CERTYFIKAT ZGODNOŚCI

NR DZC.522.162.2024
Wydanie nr 01 z dnia 13.12.2024 r.

Nazwa i adres posiadacza certyfikatu:	Alpar Spółka z o.o. Luczynów 98 26-900 Kozienice
Nazwa wyrobu:	Podstawa bezpiecznika
Typ:	PNBVA-20/4, PBNWMA 24/50
Producent:	Alpar Spółka z o.o. Luczynów 98 26-900 Kozienice
Podstawowe parametry:	Według załącznika
Zastosowanie:	Podstawy bezpiecznikowe średniego napięcia przeznaczone do instalowania w napowietrznych sieciach elektroenergetycznych o napięciu znamionowym do 20kV
Wyrób spełnia wymagania zawarte w:	PN-EN 62271-1:2018-02, PN-EN IEC 60282-1:2021-01
Zgodnie z raportem wykonanym przez:	Instytut Energetyki - Państwowy Instytut Badawczy
Nr raportu z oceny wyrobu:	DZC.522.162.2024
Okres ważności:	od 13 grudnia 2024 roku do 12 grudnia 2027 roku

Prawo do posługiwania się certyfikatem zgodności w okresie jego ważności dotyczy wyłącznie:
 • tych egzemplarzy, które spełniają wyżej określone wymagania i posiadają identyczne właściwości (parametry) jak wzory/próbki przedstawione do badań
 • posiadacza certyfikatu lub jego upoważnionego przedstawiciela

Zestawienie przypisanych parametrów wyrobu zawierają załączniki do niniejszego certyfikatu.
 Liczba załączników: 1



z up. DYREKTORA
INSTYTUTU ENERGETYKI
- PAŃSTWOWEGO INSTYTUTU BADAWCZEGO

Jarosław Herczeg
dr inż. Jarosław Herczeg

Warszawa, dnia 13.12.2024 r.



Instytut Elektrotechniki
Electrotechnical Institute
Zespół Certyfikacji Wyrobów Elektrotechnicznych
Certification Group of Electrotechnical Products



AC 168

04-703 Warszawa, ul. Mieczysława Pożaryskiego 28
tel.: +48 22 11 25 264, fax: +48 22 11 25 445, www.iel.waw.pl, e-mail: ncw@iel.waw.pl

CERTYFIKAT ZGODNOŚCI

CERTIFICATE OF CONFORMITY

Nr: DN/308/2018

NAZWA I ADRES POSIADACZA CERTYFIKATU:	ALPAR Artur i Piotr Kowalski Spółka Jawna, Luczynów 98, 26-900 Kozienice
NAZWA I ADRES PRODUCENTA:	ALPAR Artur i Piotr Kowalski Spółka Jawna, Luczynów 98, 26-900 Kozienice
NAZWA WYROBU:	Rozłączniki SNI i rozłączniko-ustalenniki SN
Produkt:	MV switches and MV switches & earthing switches
TYP / ODMIANA KONSTRUKCYJNA:	RN III SA 24/4(K,S), Rnp III SA 24/4(K,S), RNM III SA 24/4(K,S), RNP III SA 24/4(K,S), RNMp III SA 24/4(K,S), RNPp III SA 24/4(K,S)
Type / Constructional form:	VERTE
PARAMETRY: / Ratings:	PN-EN 62271-1:2005, PN-EN 62271-102:2005, PN-EN 62271-102:2005/A1:2011, PN-EN 62271-102/A2:2013-10, PN-EN 62271-103:2011
NORMY ODWIEŚNIENIA: / Reference standards:	
SPRAWOZDANIA Z BADAŃ: / Test Reports:	a) 7864/NBR/2008, 8696/NZL/NBR/15, 8771/NZL/NBR/16 b) EUR/35/E/08-2, EWN/14/E/09, EWP/59/E/2008-1
NAZWY LABORATORIÓW: / Testing laboratories:	a) Laboratorium Badawcze Aparatury Rozłączniczej IEL (Laboratorium badawcze akredytowane przez PCA, Nr AB 074) b) Laboratorium Badawcze IEN (Laboratorium badawcze akredytowane przez PCA, Nr: AB 272, AB 323 i AB 324)

TERMIN WAŻNOŚCI CERTYFIKATU: / This Certificate is valid till: 2021-06-27

NA PODSTAWIE WYŻEJ WYMIENIONYCH SPRAWOZDAŃ Z BADAŃ STWIERDZA SIĘ, ŻE WYROBY SĄ ZGODNE Z WYMAGANIAMI POWYŻSZYCH NORM.
 On the basis of the above test reports this is to certify that products fulfill the requirements of the above standards.

CERTYFIKAT JEST WAŻNY DLA WYROBÓW MAJĄCYCH IDENTYCZNE CECHY, KONFIGURACJĘ I WYPOSAŻENIE JAK BADAŃE PRÓBKİ.
 Refers only to the products having identical characteristics and arrangement as the sample submitted for testing.



PROGRAM CERTYFIKACJI PCW 1/NCW/DN TYPU 1a wg PN-EN ISO/IEC 17067:2014-01 (BADANIE TYPU, PRZEGLĄD I OCENA DOKUMENTACJI, WYDANIE CERTYFIKATU).
 Certification scheme PCW 1/NCW/DN type 1a acc. to PN-EN ISO/IEC 17067:2014-01 (type test, evaluation of documentation, issue of certificate).

Kierownik Jednostki Certyfikującej
Head of the Certification Body
Dyrektor Instytutu Elektrotechniki
Director of the Electrotechnical Institute

Tomasz Błaziejczyk
dr inż. Tomasz Błaziejczyk

Warszawa / Warsaw: 2018-06-28

Za wyróżniający się produkt elektrotechniczny
EXPOPOWER 2017
Poznań
23 maja 2017

Puchar Prezesa
Polskiego Towarzystwa Przenośności i Rozdziału Energii Elektrycznej
M. Maciejowski Europejskie Targi Włókna
JANUARIUSZ 2017

PUCIAR
Polskie Towarzystwo Przenośności i Rozdziału Energii Elektrycznej
JANUARIUSZ 2017

WYBÓR KONSUMENTÓW
ZŁOTY MEDAL 2018
EXPOPOWER
Międzynarodowe Targi Energetyki

CHAPTER 1

MV disconnectors

1. Characteristics and intended use.....	4
2. Technical data	4
3. Identification of the isolating or cut-off switch	5
4. Types and structure	6
5. Using the isolating switches.....	20
6. Inspections and maintenance.....	20

CHAPTER 2

MV air cut-off switches

1. Characteristics and intended use.....	22
2. Technical data	22
3. Identification of the isolating or cut-off switch	23
4. Types and structure	24
5. Using the cut-off switches.....	38
6. Inspections and maintenance.....	38

CHAPTER 3

MV switch disconnectors with air interrupters with switching current 100A

1. Characteristics and intended use.....	40
2. Technical data	40
3. Types and structure	42
4. Using the cut-off switches.....	50
5. Inspections and maintenance.....	50

CHAPTER 4

NRA, NRAu manual drives

1. Characteristics and intended use.....	52
2. How to order manual drives	52
3. List of manual drive components	53
4. Construction	54
5. List of drive components	54
6. Description of drive operation.....	55

NRMA, NRMAu manual drives

1. Characteristics and intended use.....	57
2. How to order manual drives	57
3. List of manual drive components	58
4. Construction	59
5. List of drive components	59
6. Description of drive operation.....	60

Motor drives

1. Characteristics and intended use.....	62
2. Advantages	62
3. Technical data	63
4. Construction and principle of operation.....	63
5. Maintenance, periodic inspections and repairs	66
6. Technical acceptance.....	66
7. Warranty terms.....	66
8. Transport and storage.....	66

CHAPTER 1

MV disconnectors

ON III SA 24/4 (K, S)
OUN III SA 24/4 (K, S)
ONp III SA 24/4 (K, S)
OUNp III SA 24/4 (K, S)
ONM III SA 24/4 (K, S)
OUNM III SA 24/4 (K, S)
ONMp III SA 24/4 (K, S)
OUNMp III SA 24/4 (K, S)
ONp III SA 24/4o (K, S)
OUNp III SA 24/4o (K, S)
ONM III SA 24/4o (K, S)
OUNM III SA 24/4o (K, S)
ONMp III SA 24/4o (K, S)
OUNMp III SA 24/4o (K, S)

1. Characteristics and intended use

The subject of the study is the construction documents of three-pole isolating and overhead isolating-earthing switches manufactured by Alpar Ltd.

The isolating switches are built on a common frame for horizontal mounting (ON, OUN) or for vertical mounting (ONp, OUNp) and on one supporting bar (ONM, OUNM). Each pole of the isolating switch consists of two stand-off insulator, one insulator is fixed and the other is movable. Electric current paths are installed on the insulators.

The isolating switches can be equipped with porcelain, composite or silicone insulators.

Overhead isolating switches of the ON type (OUN) are used in power transmission networks with voltages of 15, 20 and 30 kV. They are intended for switching on and off transmission lines that are not under load.

The isolating switches with an installed earthing switch (OUN) additionally earth the lines in the disconnected part.

ON (OUN) III SA 24/4 type isolating switches can also be used in branch lines supplying one or more transformer stations.

ON III SA 24/4 (K, S)
 OUN III SA 24/4 (K, S)
 ONp III SA 24/4 (K, S)
 OUNp III SA 24/4 (K, S)
 ONM III SA 24/4 (K, S)
 OUNM III SA 24/4 (K, S)
 ONMp III SA 24/4 (K, S)
 OUNMp III SA 24/4 (K, S)
 ONp III SA 24/4o (K, S)
 OUNp III SA 24/4o (K, S)
 ONM III SA 24/4o (K, S)
 OUNM III SA 24/4o (K, S)
 ONMp III SA 24/4o (K, S)
 OUNMp III SA 24/4o (K, S)

2. Technical data

Isolation and isolation-earthing switches have been tested. The tests have been carried out according to the following standard requirements:

PN-EN 62271-1:2018-02 High voltage switchgear and control equipment

Part 1: Common provisions

PN-EN IEC 62271-102:2018-10 High voltage switchgear and control equipment

Part 2: High voltage alternating current isolating and earthing switches

Type - version	ON(M)(p) i OUN(M)(p)	
Rated voltage U_r	24kV	
Rated frequency f_r / number of phases	50Hz / 3	
Rated withstand voltage at power frequency U_d	To the ground and interphase	50 kV
	A safe isolation break	60 kV
Rated lightning surge withstand voltage U_p (1,2/50 μ s)	To the ground and interphase	125 kV
	A safe isolation break	145 kV
Rated continuous current I_r	400 A	
Rated short-time withstand current I_k / t_k	16 kA / 1 s	
Rated peak withstand current I_p	40 kA	
Mechanical strength class of the isolating switch (5000 C-O cycles)	M2	
Motor/manual drive (type)	NEA-__ / NRA(u) / NRMA(u)	
Rated short-time withstand current of the earthing switch I_{ke} / t_k	16 kA / 1 s	
Rated peak withstand current of the earthing switch I_{pe}	40 kA	
Rated short-circuit making current of the earthing switch I_{ma}	2,5 kA	
Rated short-circuit making current of the isolating switch I_{ma}	2,5 kA	
Classification of earthing switch for short-circuit switching	E2	
Classification of the isolating switch for short-circuit switching	E2	
Operating conditions: ambient temperature	-40°C to +40°C	
Working conditions: installation height above sea level	< 1000 m	

3. Manufacturer's code of the isolating or cut-off switch

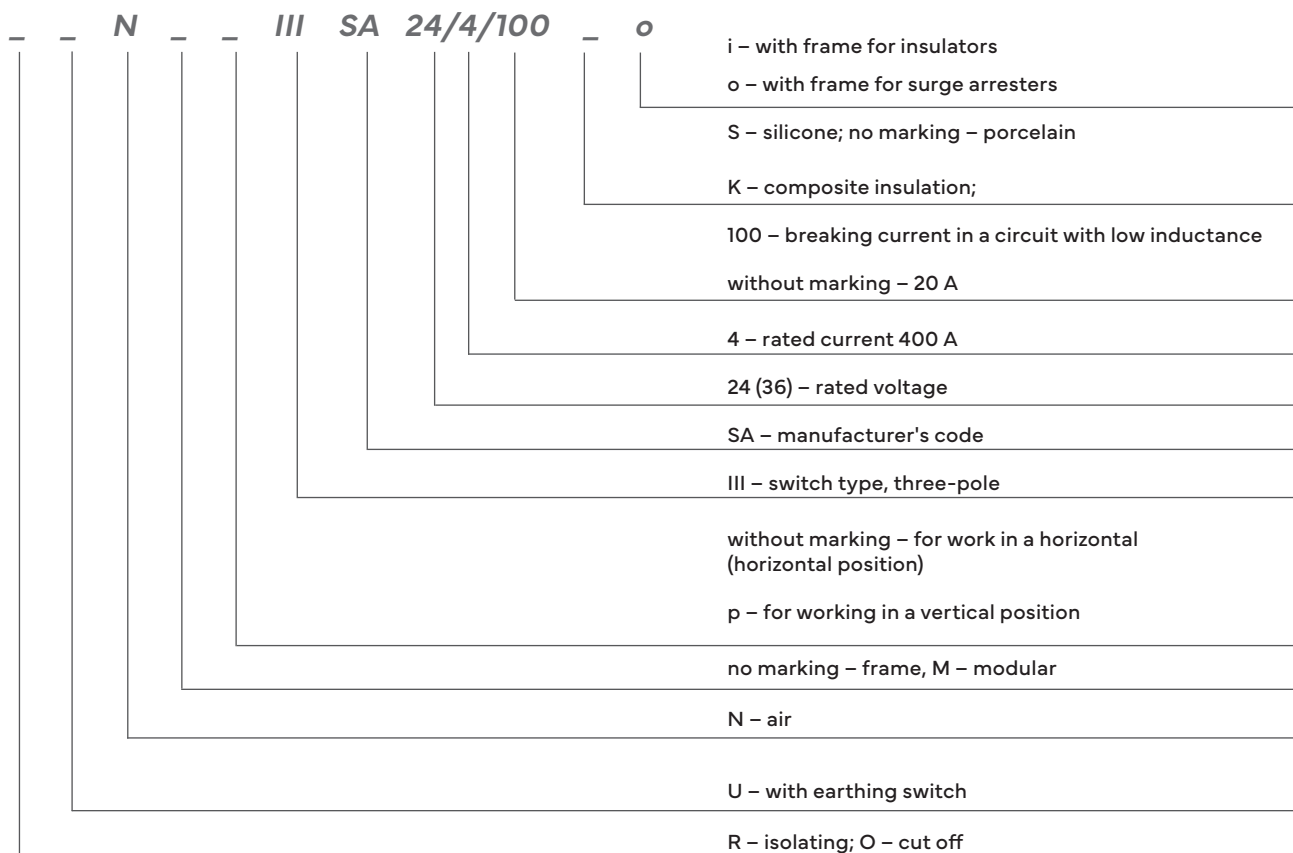

Marking examples:

OUN III SA 24/4

– three-pole overhead isolating-earthing switch 24 kV / 400 A with porcelain insulation

RUNMp III SA 24/4

– outdoor modular vertical three-pole cut off-earthing switch 24 kV / 400 A with porcelain insulation

ONp III SA 24/4 S

– vertical three-pole overhead isolating switch 24 kV / 400 A with silicone insulation

RUNM III SA 24/4 Ko

– outdoor modular three-pole cut-off-earthing switch 24 kV / 400 A with composite insulation and structure for surge arresters

RNM III SA 24/4/100S

– three-pole modular overhead cut-off switch 24 kV / 400 A / 100 A with silicone insulation

4. Types and structure

4.1. Frame isolating switches – horizontal installation on a pole.

Type ON (OUN) III SA 24/4 overhead isolating switches have a three-pole structure with a common base (frame) and a common drive for all poles. Each pole of the isolating switch is built on two stand-off insulators. One insulator is attached to the base (frame) and the other to the bearing-mounted movable beam. This structure ensures simultaneous closing and opening of all poles.

Isolating switches are normally made of porcelain insulators. Additionally, they can be equipped with insulators:

- ON (CUN) III SA 24/4 K – composite
- ON (CUN) III SA 24/4 S – silicone

At the customer's request, other insulators with a valid certificate can be used.

Electric current path of each pole consists of main contacts. These elements are mounted on support holder placed directly on the support insulators.

The main current path consists of a flat fixed contact and two profiled moving contacts screwed together. The moving contacts of the current path have been profiled in a shape that ensures trouble-free self-guidance and a large contact surface. Additionally, the mounting of the movable contacts has a technical clearance, thanks to which the contact surface between the movable contacts

and the fixed contact (or earthing switch contact) is optimal. As standard, the main contacts are made of copper flat bar, protected against corrosion by tinning, and can additionally be silver-plated.

Each movable pole of the isolating switch is standardly equipped with a movable joint with a current terminal of 16-95 mm², on request 120 mm². The joint is designed to prevent the cable or power cord from breaking. A cord or wire with a cross-section of up to 95 (120) mm² can be connected to the terminal. To ensure the optimal current flow path, the connection terminal is connected to the main contact through a flexible copper connector. A feeder clamp is used to connect a cable or power cable from the side of the permanent contact, which also allows you to connect a cable with a cross-section of up to 95 (120) mm².

The frame of the isolating switches is made of closed profiles and cold-formed sections. Corrosion protection is provided by a zinc coating made by immersion. The ON (OUN) III SA 24/4 isolating switches are designed for horizontal installation on all standard power structures used in the municipal power industry.

The isolating switch is controlled by using a manual drive type NRA(u) or a motor drive NEA. The drives are coupled to the switch's drive mechanism using 2 M10 screws.

Basic solutions

○ ON III SA 24/4 type isolating switch

03-001
ON III SA 24/4

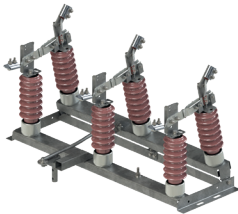

○ OUN III SA 24/4 type isolating-earthing switch

03-002
OUN III SA 24/4

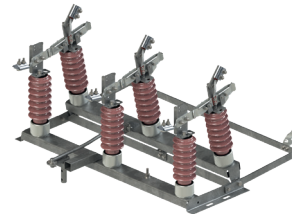

03-005
ON III SA 24/4K

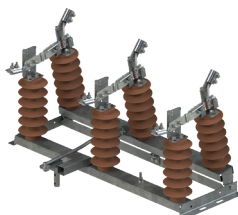

03-006
OUN III SA 24/4K

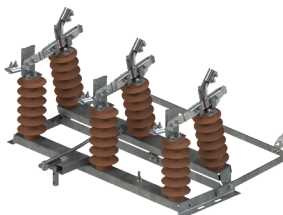

03-009
ON III SA 24/4S

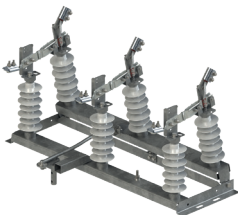

03-010
OUN III SA 24/4S

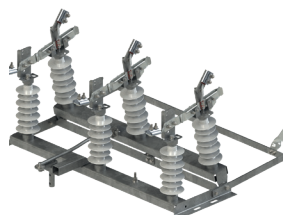

Basic dimensions

○ ON III SA 24/4 type isolating switch

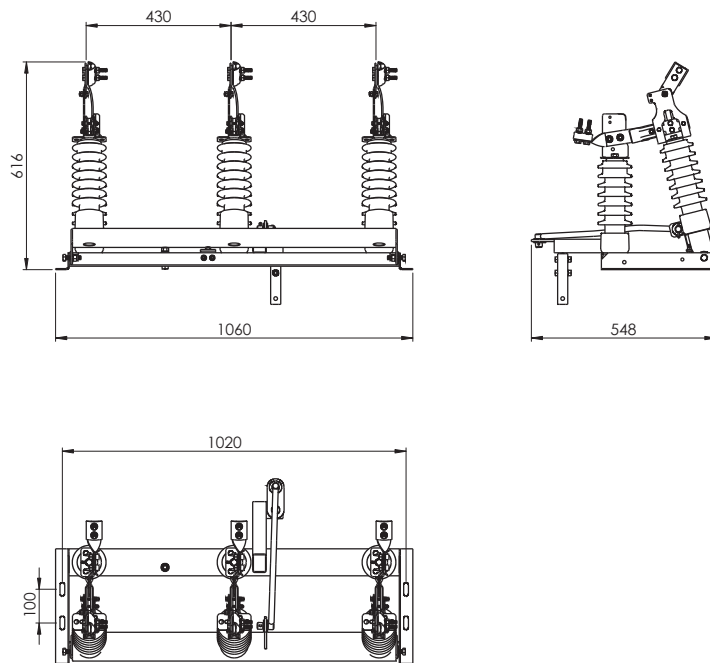

○ OUN III SA 24/4 type isolating-earthing switch

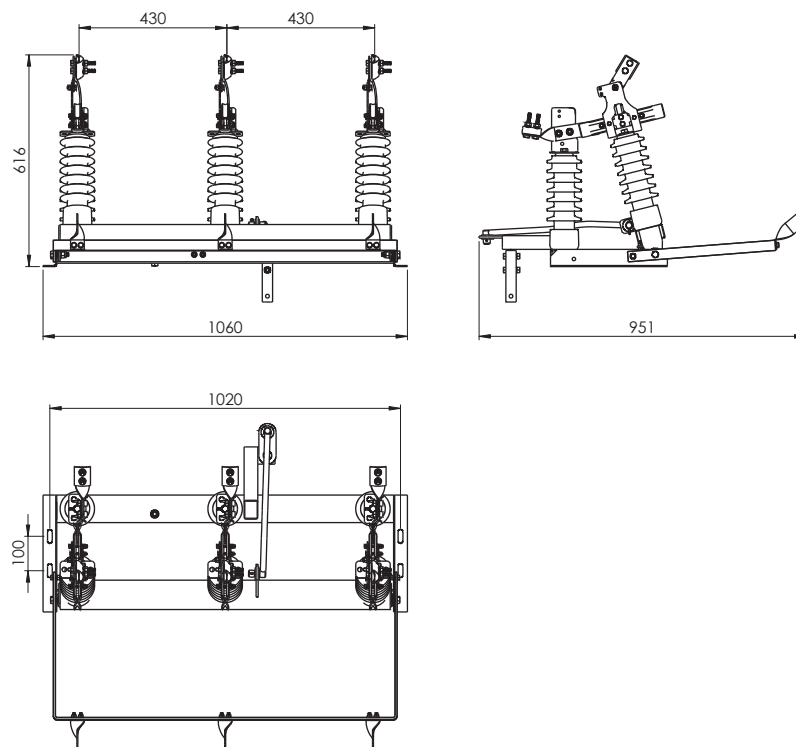

4.2. Frame isolating switches – vertical installation on a pole.

The overhead isolating switches type ONp (OUNp) III SA 24/4 have a three-pole structure with a common base (frame) and a common drive for all poles. An integral part of each vertical isolating switch is the structure attaching it to the pole leg. Each pole of the isolating switch is built on two support insulators. One insulator is attached to the base (frame) and the other to the bearing-mounted movable beam. This construction ensures the simultaneous closing and opening of all poles.

Isolating switches are normally made of porcelain insulators. Additionally, they can be equipped with insulators:

- ONp (OUNp) III SA 24/4 K – composite
- ONp (OUNp) III SA 24/4 S – silicone

At the customer's request, other insulators with a valid certificate can be used.

The current path of each pole consists of main contacts. These elements are mounted on support holder placed directly on the support insulators.

The main current path consists of a flat fixed contact and two profiled moving contacts screwed together. The moving contacts of the current path have been profiled to ensure trouble-free self-guidance and a large contact surface. Additionally, the mounting of

the movable contacts has a technical clearance, thanks to which the contact surface between the movable contacts and the fixed contact (or earthing switch contact) is optimal. As standard, the main contacts are made of flat copper, protected against corrosion by tinning, and can additionally be silver-plated.

Each movable pole of the isolating switch is standardly equipped with a movable joint with a feeder clamp of 16–95 mm², on request 120 mm². The joint is designed to prevent the cable or power cord from breaking. A rope or wire with a cross-section of up to 95 (120) mm² can be connected to the terminal. To ensure an optimal current flow path, the connection terminal is connected to the main contact via a flexible copper connector. A current terminal is used to connect a cable or power cable from the side of the permanent contact, which also allows the connection of a cable with a cross-section of up to 95 (120) mm².

The frame of the isolating switches is made of closed profiles and cold-formed sections. Corrosion protection is provided by a zinc coating made by immersion. ONp (OUNp) III SA 24/4 isolating switches are designed for installation directly on a pole leg.

The isolating switch is controlled by using a manual drive of the NRA(u) type or an NEA motor drive. The drives are coupled to the switch's drive mechanism using 2 M10 screws.

Basic solutions

○ ONp III SA 24/4 type isolating switch

○ OUNp III SA 24/4 type isolating-earthing switch

03-033
ONp III SA 24/4



03-034
OUNp III SA 24/4

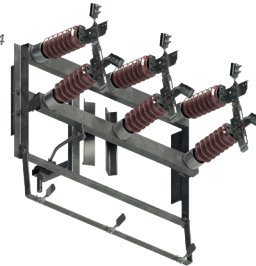

03-037
ONp III SA 24/4K



03-038
OUNp III SA 24/4K



03-041
ONp III SA 24/4S

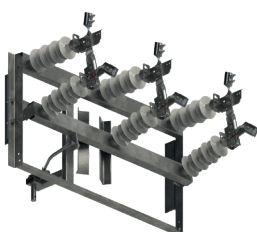

03-042
OUNp III SA 24/4S



Basic dimensions

○ ONp III SA 24/4 type isolating switch

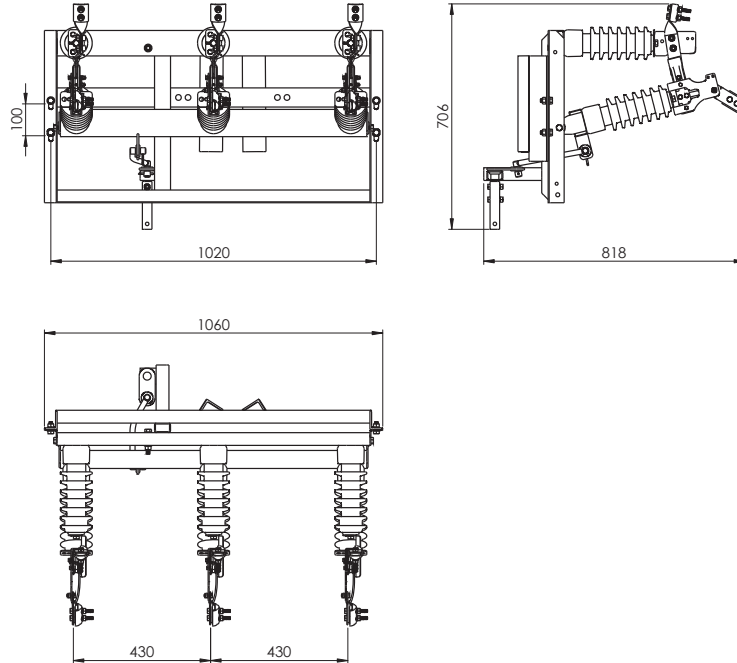

○ OUNp III SA 24/4 type isolating-earthing switch

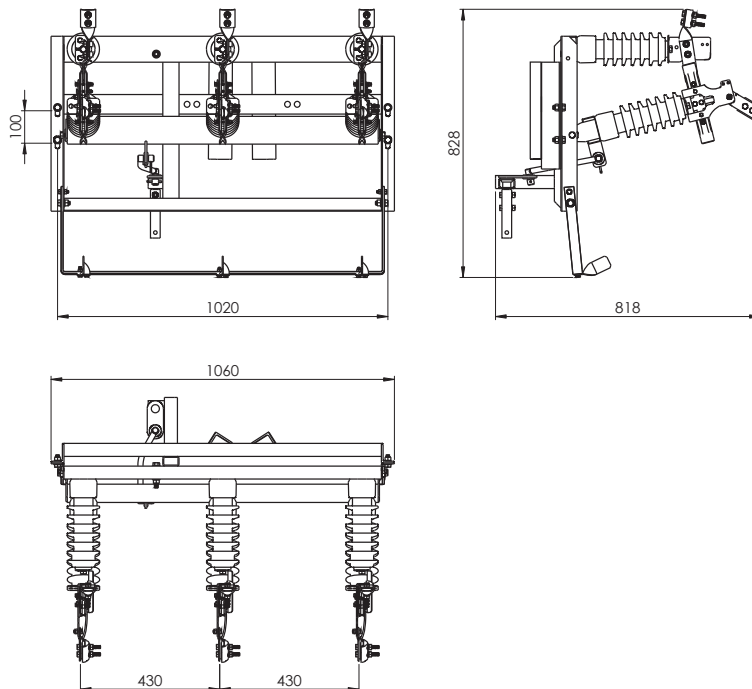

4.3. Modular isolating switches – horizontal installation on a pole.

The modular structure of ONM (OUNM) III SA 24/4 isolating switches allows you to independently set the poles relative to each other while maintaining minimum, safe distances. These isolating switches can be installed at the top (above the pole conductors) and on the pole leg in a horizontal position.

When ordering a modular isolating switch (isolating switch–earthing switch) intended for installation on the top of a pole, please provide the type of structure to which the switch is to be attached (see: **Booklet 5: Fixing switches in overhead MV lines**). When ordering a modular isolating switch (isolating switch–earthing switch) intended for mounting to a pole leg, please provide the top diameter of the spun pole.

Overhead isolating switches type ONM (OUNM) III SA 24/4 have an asymmetric three-pole structure with a common support beam and a common drive for all poles. Each pole of the isolating switch is built on two support insulators. One insulator is attached to the structure permanently, the other is attached to the movable structure with bearings. The movable structures of all three poles are connected by one profile. The handle of the switch driving mechanism is attached to the profile; this structure ensures simultaneous closing and opening of all poles.

Modular isolating switches are usually built on porcelain insulators. Additionally, they can be equipped with insulators:

- ONM (OUNM) III SA 24/4 K – composite
- ONM (OUNM) III SA 24/4 S – silicone

At the customer's request, other insulators with a valid certificate can be used.

The current path of each pole consists of main contacts. These elements are mounted on support holder placed directly on the support insulators. The main current path consists of a flat fixed contact and two profiled moving contacts screwed together. The moving contacts of the current path have been profiled to ensure trouble-free self-guidance and a large contact surface. Additionally, the mounting of the movable contacts has technical clearance, thanks to which the contact surface of the movable contacts with the fixed contact (or earthing switch contact) is optimal. As standard, the main contacts are made of flat copper, protected against corrosion by tinning, and can additionally be silver-plated.

Each movable pole of the isolating switch is equipped with a movable joint with a feeder clamp of 16-95 mm², on request 120 mm². The joint is designed to prevent the rope or power cord from breaking. A rope or wire with a cross-section of up to 95 (120) mm² can be connected to the terminal. To ensure the optimal current flow path, the connection terminal is connected to the main contact through a flexible copper connector. A feeder clamp is used to connect a cable or power cable from the side of the permanent contact, which also allows you to connect a cable with a cross-section of up to 95 (120) mm².

Corrosion protection is provided by immersion zinc plating.

The isolating switch is controlled by using a manual drive type NRA(u) or a motor drive NEA. The drives are coupled to the switch's drive mechanism using 2 M10 screws.

Modular isolating switches can be controlled by a reciprocating drive, NRMA(u) type. Details of connection and operation are shown in section 4 NRMA, NRMAu hand drives.

Basic solutions

○ ONM III SA 24/4 isolating switch

03-049
ONM III SA 24/4

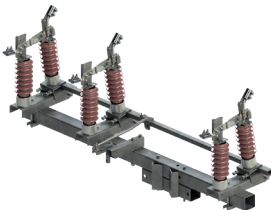

○ OUNM III SA 24/4 type isolating-earthing switch

03-050
OUNM III SA 24/4

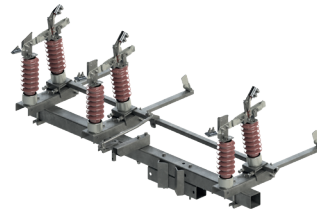

03-053
ONM III SA 24/4K

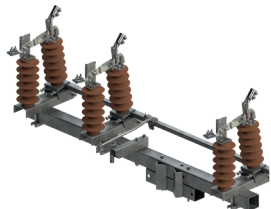

03-054
OUNM III SA 24/4K

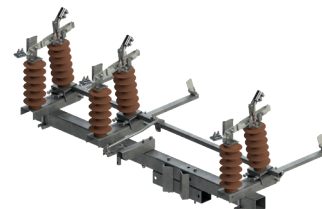

03-057
ONM III SA 24/4S

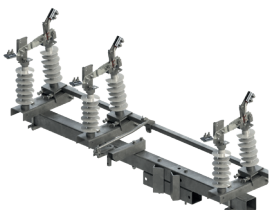

03-058
OUNM III SA 24/4S

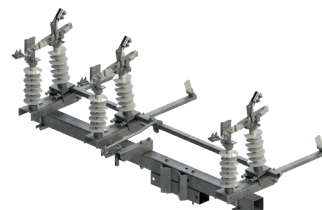

Basic dimensions

- ONM III SA 24/4 isolating switch

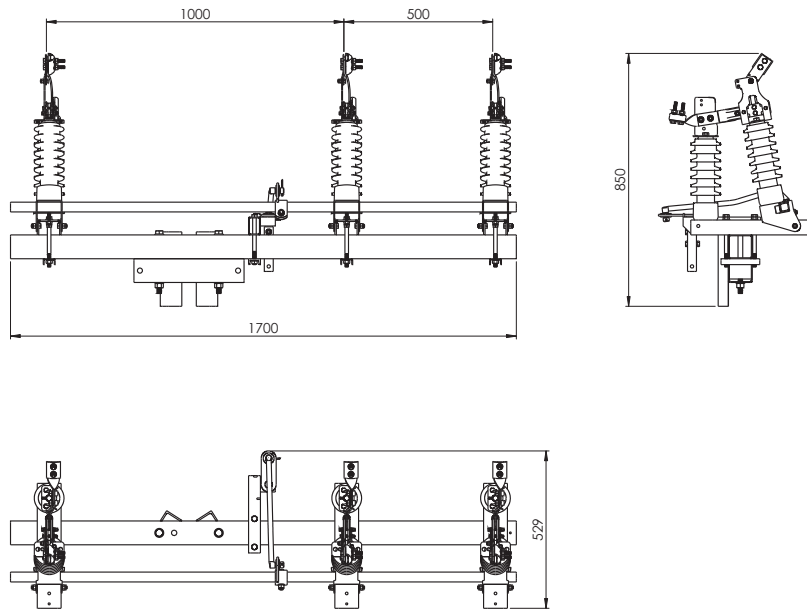

- OUNM III SA 24/4 type isolating-earthing switch

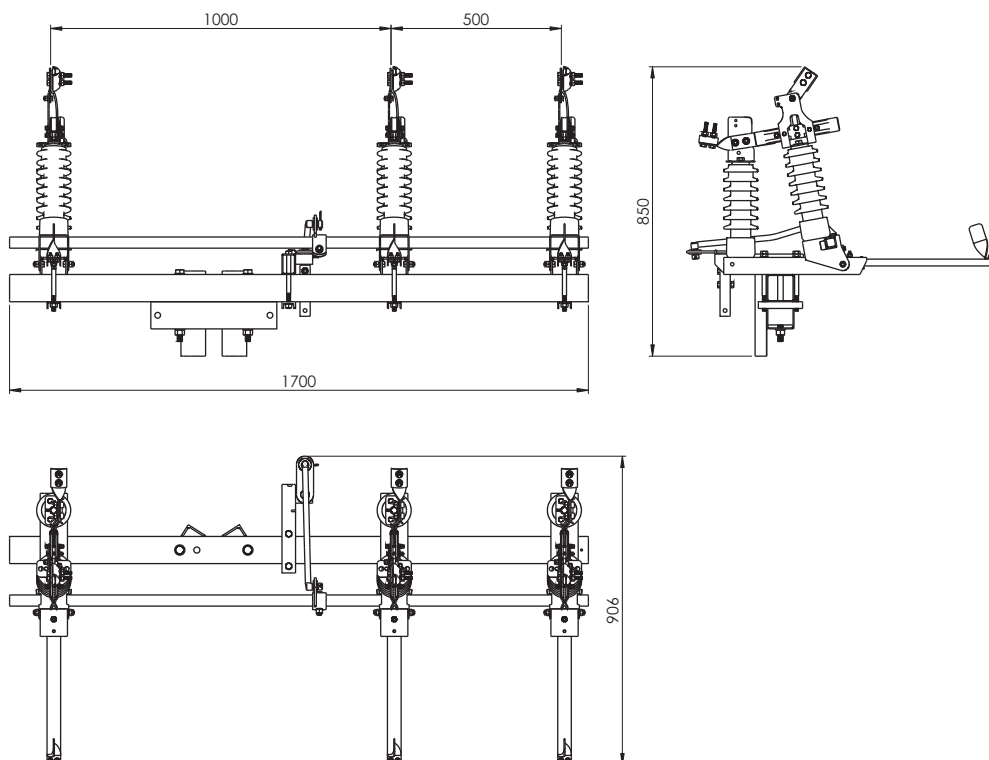

4.4. Modular isolating switches – vertical installation on a pole.

The modular structure of ONMp () III SA 24/4 isolating switches allows for independent positioning of the poles relative to each other, maintaining minimum, safe distances. These isolating switches can only be installed on a pole leg in a vertical position.

When ordering a modular vertical isolating switch (isolating switch-earthing switch), please provide the top diameter of the spun pole.

Outdoor isolating switches type ONMp (OUNMp) III SA 24/4 have an asymmetrical three-pole structure with a common support beam and a common drive for all poles. Each pole of the isolating switch is built on two support insulators. One insulator is permanently attached to the structure, the other is attached to a movable structure with bearings. The movable structures of all three poles are connected by one profile. The handle of the switch's drive mechanism is attached to the profile; this design ensures simultaneous closing and opening of all poles.

Modular isolating switches are usually built on porcelain insulators. Additionally, they can be equipped with insulators:

- ONMp (OUNMp) III SA 24/4 K – composite
- ONMp (OUNMp) III SA 24/4 S – silicone

At the customer's request, other insulators with a valid certificate can be used.

The current path of each pole consists of main contacts. These elements are mounted on support holder placed directly on the support insulators. The main current path consists of a flat fixed contact and two profiled moving contacts screwed together.

The moving contacts of the current path have been profiled in a shape that ensures trouble-free self-guidance and a large contact surface. Additionally, the mounting of the movable contacts has a technical clearance, thanks to which the contact surface between the movable contacts and the fixed contact (or earthing switch contact) is optimal. As standard, the main contacts are made of copper flat bar, protected against corrosion by tinning, and can additionally be silver-plated.

Each movable pole of the isolating switch is equipped with a movable joint with a current terminal of 16-95 mm², on request 120 mm². The joint is designed to prevent the rope or power cord from breaking. A rope or wire with a cross-section of up to 95 (120) mm² can be connected to the terminal. To ensure an optimal current flow path, the connection terminal is connected to the main contact via a flexible copper connector. A current terminal is used to connect a cable or power cable from the side of the permanent contact, which also allows the connection of a cable with a cross-section of up to 95 (120) mm².

Corrosion protection is provided by a zinc coating made by immersion.

The isolating switch is controlled by using a manual drive type NRA(u) or a motor drive NEA.

The drives are coupled to the switch's drive mechanism using 2 M10 screws.

Modular isolating switches can be controlled by a reciprocating drive, NRMA(u) type. Details of connection and operation are shown in section 4 NRMA, NRMAu hand drives.

Basic solutions

○ ONMp III SA 24/4 type isolating switch

03-017
ONMp III SA 24/4

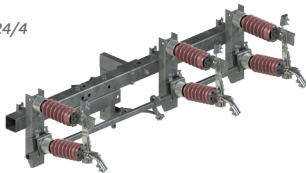

03-021
ONMp III SA 24/4K

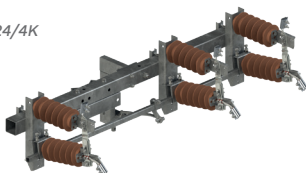

03-025
ONMp III SA 24/4S

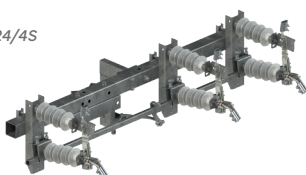

○ OUNMp III SA 24/4 type isolating-earthing switch

03-018
OUNMp III SA 24/4



03-022
OUNMp III SA 24/4K

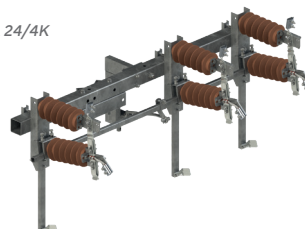

03-026
OUNMp III SA 24/4S

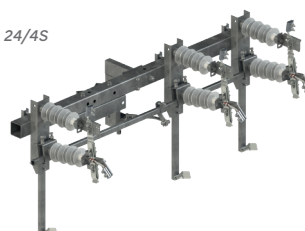

Basic dimensions

○ ONMp III SA 24/4 type isolating switch

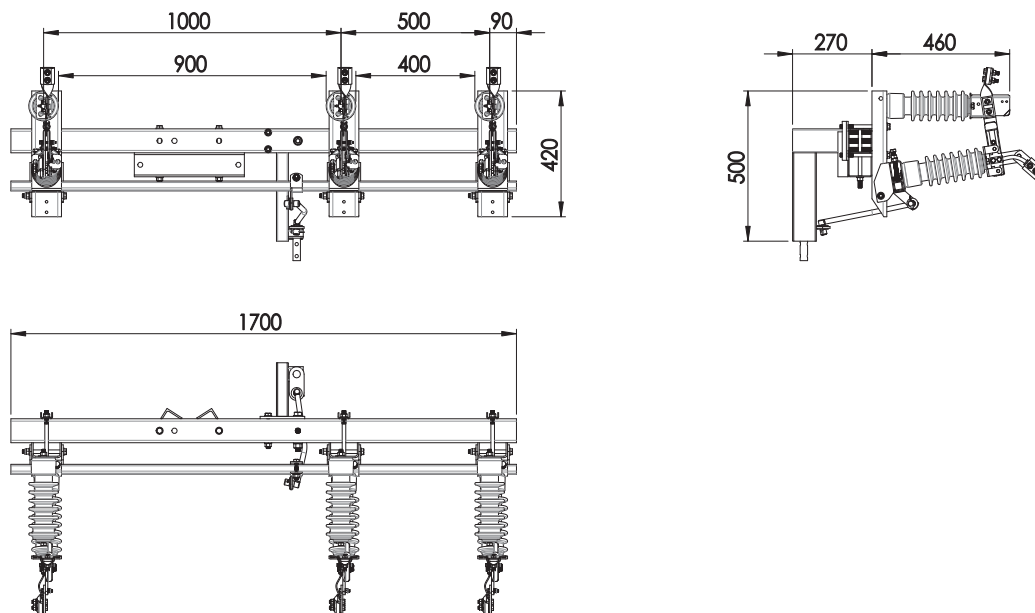

○ OUNMp III SA 24/4 type isolating-earthing switch

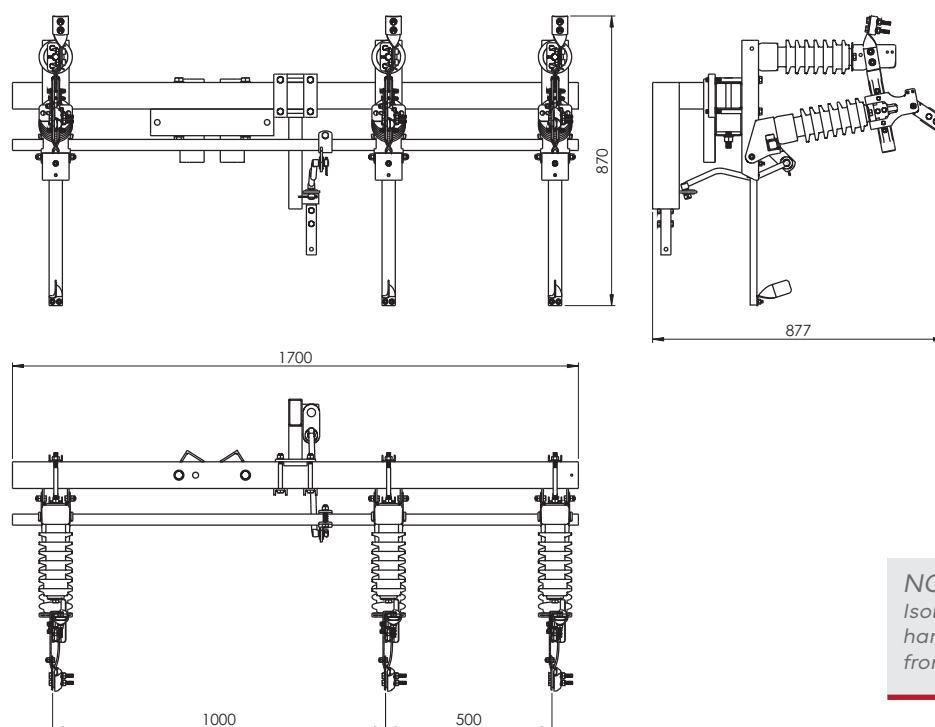

NOTE!
 Isolating switches with left-hand movement. Opening from left to right

4.5. Frame isolating switches with construction ready for MV surge arresters - vertical installation on a pole.

The overhead isolating switches type ONp (OUNp) III SA 24/4o have a three-pole structure with a common base (frame) and a common drive for all poles. An integral part of each vertical isolating switch is the structure attaching to the pole leg. Each pole of the isolating switch is built on two support insulators. One insulator is attached to the base (frame) and the other to the bearing-mounted movable beam. This structure ensures simultaneous closing and opening of all poles.

Isolating switches are normally made of porcelain insulators. Additionally, they can be equipped with insulators:

- ONp (OUNp) III SA 24/4Ko – composite
- ONp (OUNp) III SA 24/4So – silicone

At the customer's request, other insulators with a valid certificate can be used.

The current path of each pole consists of main contacts. These elements are mounted on support holder placed directly on the support insulators. The main current path consists of a flat fixed contact and two profiled contacts screwed together. The moving contacts of the current path have been profiled to ensure trouble-free self-guidance and a large contact surface. Additionally, the mounting of the movable contacts has technical clearance, thanks to which the contact surface of the movable contacts with the fixed contact (or earthing switch contact) is optimal. As standard, the main contacts are made of flat copper, protected against corrosion by tinning, and can additionally be silver-plated.

Each movable pole of the isolating switch is standardly equipped with a movable joint with a current terminal of 16-95 mm², on request 120 mm². The joint is designed to prevent the cable or power cord from breaking. The LGY bridge ended with a copper mounting plate is factory-installed to the current terminal. The necessary holes were made in the mounting plate to assemble the bridge with a surge arrester and a cable head end. To ensure an optimal current flow path, the connection terminal is connected to the main contact via a flexible copper connector. A feeder clamp is used to connect a cable or power cable from the side of the permanent contact, which also allows the connection of a cable with a cross-section of up to 95 (120) mm². The frame of the isolating switches is made of closed profiles and cold-formed sections. Corrosion protection is provided by a zinc coating made by immersion.

A frame for surge arresters or support insulators is attached to the frame of the isolating switches as standard - so there is no need to install an additional structure for the surge arresters. This solution provides more space on the pole and reduces implementation time and investment costs.

ONp (OUNp) III SA 24/4o isolating switches are designed for mounting directly on a pole leg.

The isolating switch is controlled by using a manual drive type NRA(u) or a motor drive NEA.

The drives are coupled to the switch's drive mechanism using 2 M10 screws.

Basic solutions

○ ONp III SA 24/4o type isolating switch

03-033.1
ONp III SA 24/4o

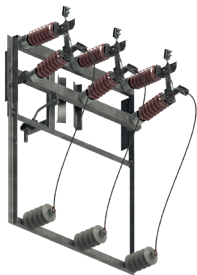

03-037.1
ONp III SA 24/4Ko

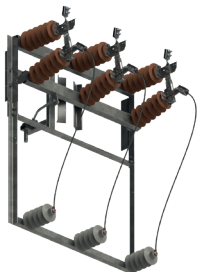

03-041.1
ONp III SA 24/4So

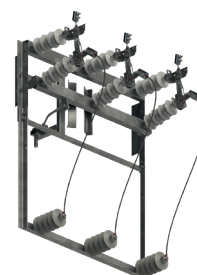

○ OUNp III SA 24/4o type isolating-earthing switch

03-034.1
OUNp III SA 24/4o

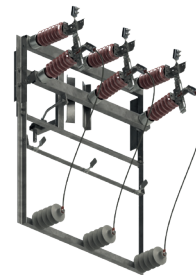

03-038.1
OUNp III SA 24/4Ko

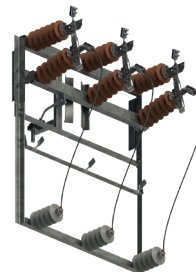

03-042.1
OUNp III SA 24/4So

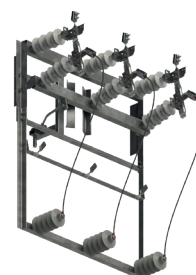

Basic dimensions

- ONp III SA 24/40 type isolating switch

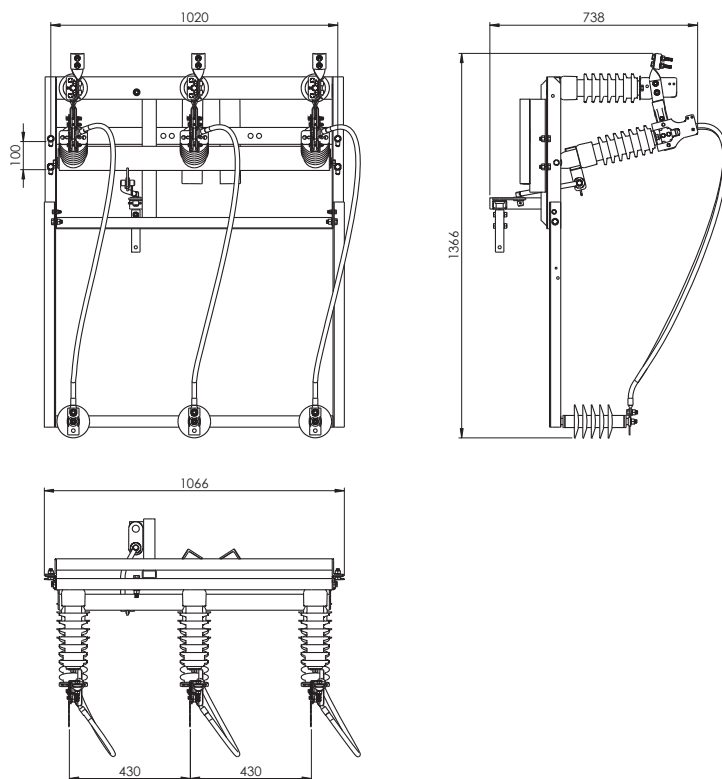

NOTE!
Surge arresters or post insulators are not standardly included in the price of the product!

- OUNp III SA 24/40 type isolating-earthing switch

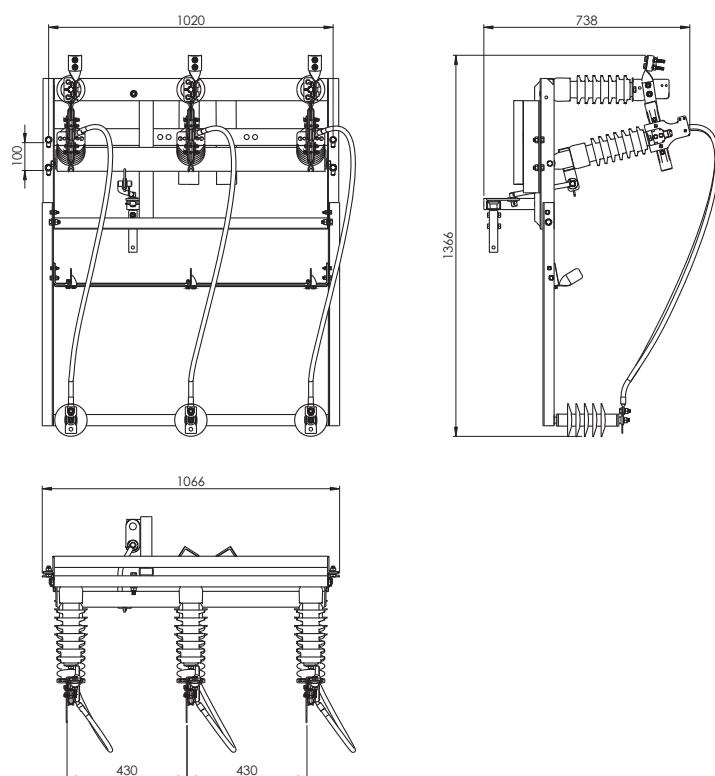

4.6. Modular isolating switches with with construction ready for MV surge arresters - horizontal installation on a pole.

The modular structure of ONM (OUNM) III SA 24/4o isolating switches allows you to independently set the poles relative to each other, maintaining minimum, safe distances. These isolating switches can be installed at the top (above the pole conductors) and on the pole leg in a horizontal position.

When ordering a modular isolating switch (isolating switch-earthing switch) intended for installation on the top of a pole, please provide the type of structure to which the switch is to be attached (see: **Booklet: 4 Fixing switches in overhead MV lines**). When ordering a modular isolating switch (isolating switch-earthing switch) intended for mounting to a pole leg, please provide the top diameter of the spun pole.

Overhead isolating switches type ONM (OUNM) III SA 24/4o have an asymmetric three-pole structure with a common support beam and a common drive for all poles. Each pole of the isolating switch is built on two support insulators. One insulator is attached to the structure permanently, the other is attached to the movable structure with bearings. The movable structures of all three poles are connected by one profile. The handle of the switch driving mechanism is attached to the profile; this structure ensures simultaneous closing and opening of all poles.

Modular isolating switches are usually built on porcelain insulators. Additionally, they can be equipped with insulators:

- ONM (OUNM) III SA 24/4Ko – composite
- ONM (OUNM) III SA 24/4So – silicone

The current circuit of each pole consists of main contacts. These elements are mounted on support holder placed directly on the support insulators. The main current path consists of a flat fixed contact and two profiled moving contacts screwed together.

The moving contacts of the current path have been profiled to ensure trouble-free self-guidance and a large contact surface. Additionally, the mounting of the movable contacts has a technical clearance, thanks to which the contact surface of the movable contacts with the fixed contact (or earthing switch contact) is optimal. As standard, the main contacts are made of flat copper, protected against corrosion by tin plating, and can also be silver-plated. Each movable pole of the isolating switch is equipped with a movable joint with a feeder clamp of 16-95 mm², on request 120 mm². The joint is designed to prevent the cable or power cord from breaking.

An LGY bridge with a copper mounting plate is factory-installed to the current terminal. The necessary holes were made in the mounting plate to assemble the bridge with the surge arrester and the cable head end.

To ensure an optimal current flow path, the terminal is connected to the main contact via a flexible copper connector. A feeder clamp is used to connect a cable or power cable from the side of the permanent contact, which also allows you to connect a cable with a cross-section of up to 95 (120) mm².

Standard structures for surge arresters or support insulators are attached to the main beam of the isolating switch - so there is no need to install an additional structure for surge arresters. This solution provides more space on the pole and reduces implementation time and investment costs.

The isolating switch is controlled by using a manual drive type NRA(u) or a motor drive NEA.

Modular isolating switches can be controlled by a reciprocating drive, type NRMA(u). Details of connection and operation are shown in section 4 NRMA, NRMAu hand drives.

Basic solutions

○ ONM III SA 24/4o type isolating switch

03-065
ONM III SA 24/4o

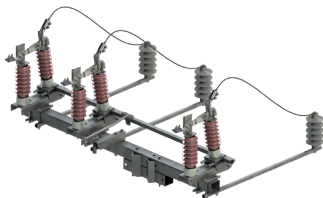

03-069
ONM III SA 24/4Ko

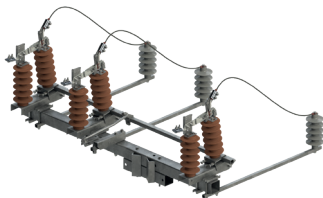

03-073
ONM III SA 24/4So

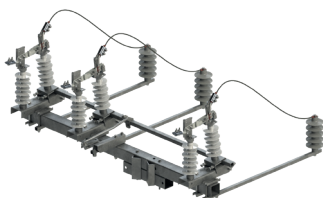

○ OUNM III SA 24/4o type isolating-earthing switch

03-066
OUNM III SA 24/4o

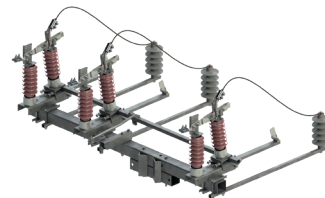

03-070
OUNM III SA 24/4Ko

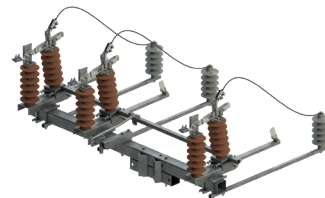

03-074
OUNM III SA 24/4So

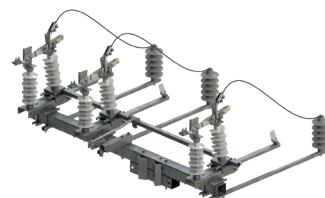

Basic dimensions

- ONM III SA 24/4o type isolating switch

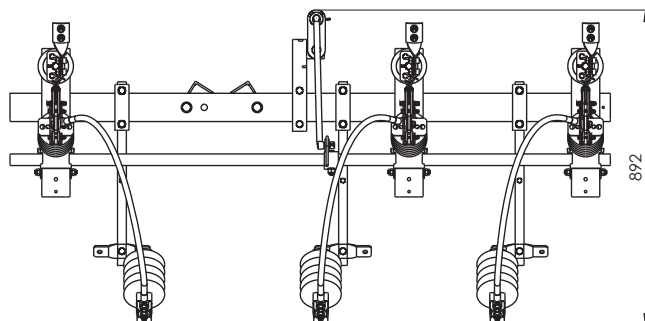
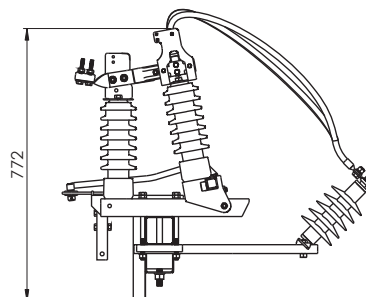
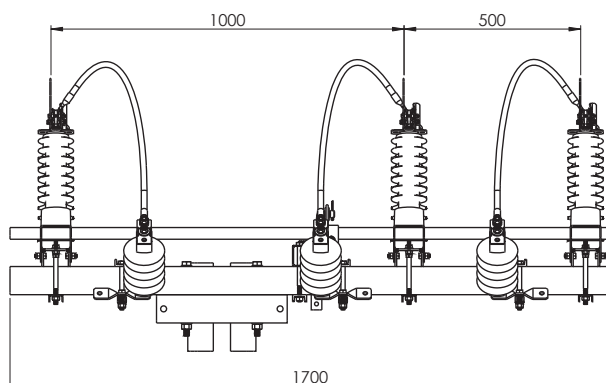

NOTE!
ALPAR's offer also includes isolating (ONM) and isolating-earthing switches (OUNM) with their own structure for mounting support insulators.

- OUNM III SA 24/4o type isolating-earthing switch

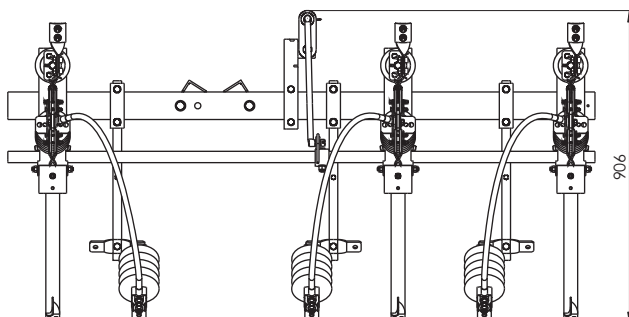
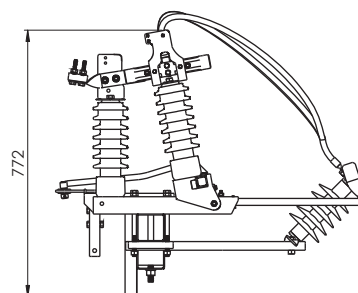
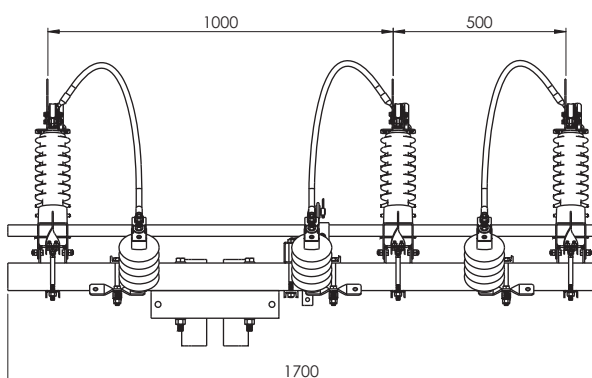

NOTE!
Surge arresters or post insulators are not standardly included in the price of the product!

4.7. Modular isolating switches with with construction ready for MV surge arresters - vertical installation on a pole.

The modular structure of ONMp (OUNMp) III SA 24/4o isolating switches allows you to independently set the poles relative to each other while maintaining minimum, safe distances. These isolating switches can only be installed on a pole leg in a vertical position. When ordering a modular vertical isolating switch (isolating switch-earthing switch), please provide the top diameter of the rotating pole. ONMp (OUNMp) III SA24/4o type overhead isolating switches have an asymmetric three-pole structure with a common support beam and a common drive for all poles. Each pole of the isolating switch is built on two support insulators. One insulator is permanently attached to the structure, the other is attached to a movable structure with bearings. The movable structures of all three poles are connected by one profile. The handle of the switch driving mechanism is attached to the profile; this structure ensures simultaneous closing and opening of all poles.

Modular isolating switches are usually built on porcelain insulators. Additionally, they can be equipped with insulators:

- ONMp (OUNMp) III SA 24/4Ko – composite
- ONMp (OUNMp) III SA 24/4So – silicone

The current path of each pole consists of main contacts. These elements are mounted on support holder placed directly on the support insulators. The main current path consists of a flat fixed contact and two profiled movable contacts twisted together.

The moving contacts of the current path have been profiled in a shape that ensures trouble-free self-guidance and a large contact surface.

Additionally, the mounting of the movable contacts has a technical clearance, thanks to which the contact surface between the movable contacts and the fixed contact (or earthing switch contact) is optimal. As standard, the main contacts are made of flat copper, protected against corrosion by tinning, and can additionally be silver-plated. Each movable pole of the isolating switch is equipped with a movable joint with a current terminal of 16-95 mm², on request 120 mm². The joint is designed to prevent the cable or power cord from breaking.

An LGY bridge with a copper mounting plate is factory-installed to the current terminal. The necessary holes are made in the mounting plate to assemble the bridge with a surge arrester and a cable header tip.

To ensure an optimal current flow path, the connection terminal is connected to the main contact via a flexible copper connector. A feeder clamp is used to connect a cable or power cable from the side of the permanent contact, which also allows the connection of a cable with a cross-section of up to 95 (120) mm².

Standard structures for surge arresters or support insulators are attached to the main beam of the isolating switch - so there is no need to install an additional structure for surge arresters. This solution provides more space on the pole and reduces implementation time and investment costs.

The isolating switch is controlled by using a manual drive type NRA(u) or a motor drive NEA.

Modular isolating switches can be controlled by a reciprocating drive, type NRMA(u). Details of connection and operation are shown in section 4 NRMA, NRMAu hand drives.

Basic solutions

○ ONMp III SA 24/4o type isolating switch

03-077
ONMp III SA 24/4o

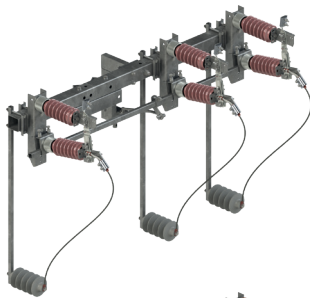

03-081
ONMp III SA 24/4Ko

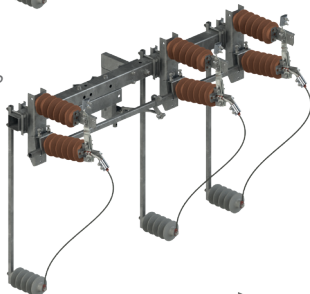

03-085
ONMp III SA 24/4So

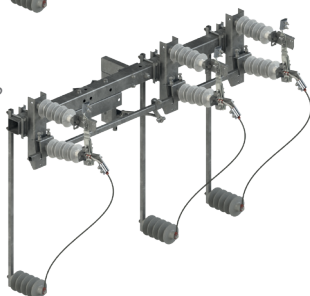

○ OUNMp III SA 24/4o type isolating-earthing switch

03-078
OUNMp III SA 24/4o



03-082
OUNMp III SA 24/4Ko

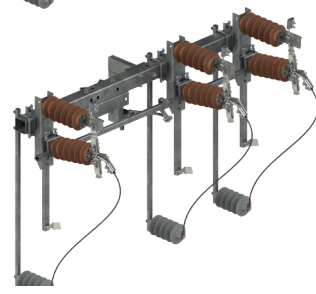

03-086
OUNMp III SA 24/4So

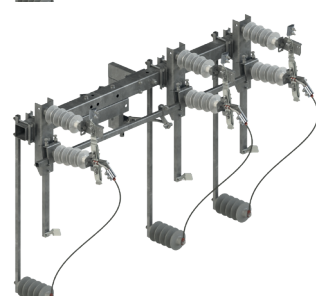

Basic dimensions

- ONMp III SA 24/4o type isolating switch

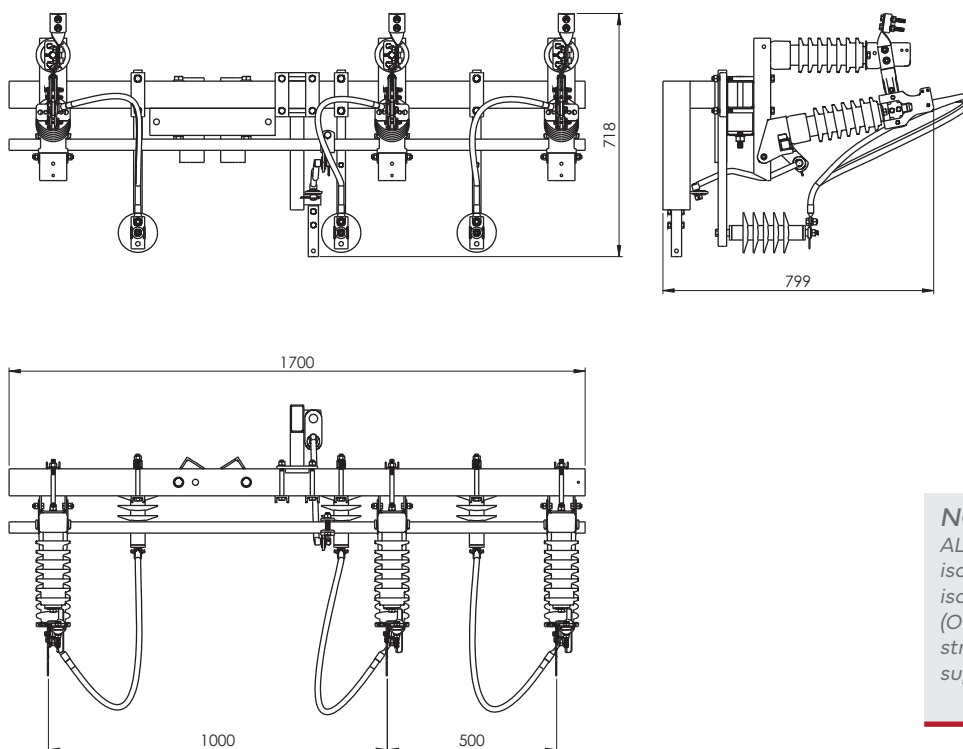

NOTE!
ALPAR's offer also includes isolating (ONMp) and isolating-earthing switches (OUNMp) with their own structure for mounting support insulators

- OUNMp III SA 24/4o type isolating-earthing switch

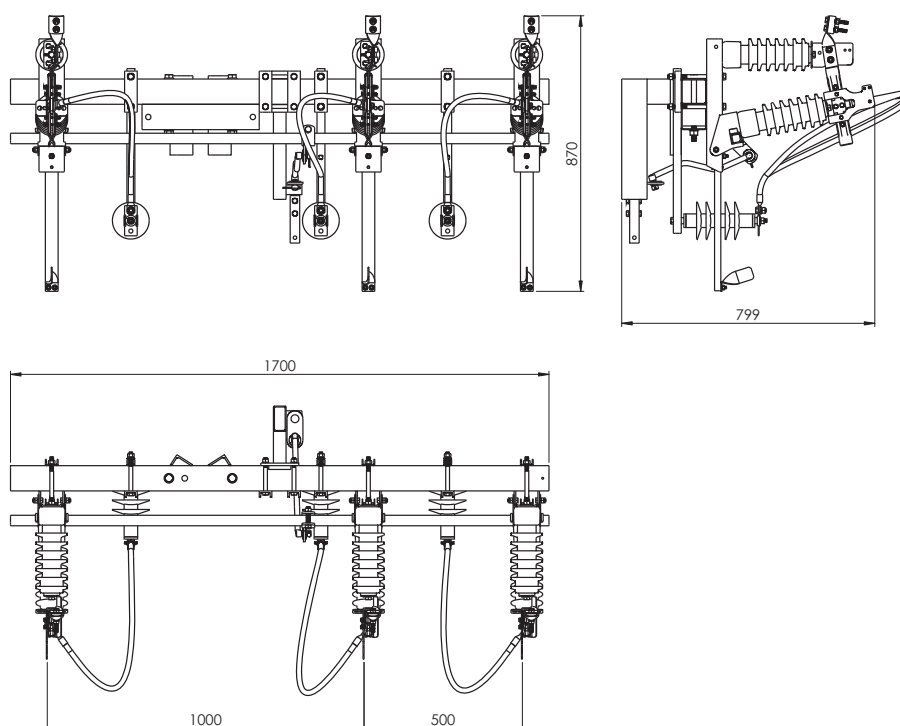

NOTE!
Surge arresters or post insulators are not standardly included!

NOTE!
Left-hand movement isolating switches. Opening from left to right.

5. Using isolating switches

Immediately after receiving the isolating switch, check whether the delivery is consistent with the order and the general condition of the isolating switch.

The devices should be carried during unloading, loading and assembly by grasping only the base (beam).

NOTE!

It is unacceptable to grab the elements of the current circuit and the support insulators of the disconnecter.

The isolating switches are delivered to the customer completely assembled and adjusted - always in the closed position. After unpacking, check whether the device has not suffered any mechanical damage during transport and whether the data on the rating plate are consistent.

When mounting the isolating switch on a pole and coupling it with the NRA(u) or NRMA(u) manual drive, the device should be in the closed position. When installing the handwheel, the drive key should be on the right side in the closed position.

NOTE!

Does not apply to modular isolating switches operating in a vertical position. In this group of isolating switches, the key should be on the left side.

NOTE!

Installing drives other than NRA(u) and NRMA(u) drives is possible after contacting the manufacturer.

As standard, the isolating switches are designed to connect conductors with a cross-section of up to 95 mm². Before connection, it is recommended to clean the contact surfaces of the connecting elements (connection terminals) from any possible contamination and lubricate them with a thin layer of conductive grease (acid-free).

Before putting the isolating switch into operation, check the condition of the device, correct coupling with the drive and correct operation. The isolating switch should be visually inspected, checking the condition of the insulators (dirt, cracks, etc.) and the correct tightening of screw connections - in particular cable connections, connection to the drive and the attachment of the device to the supporting structure. Then perform several switching cycles, paying attention to the proper operation of the main contacts (recharging when closing).

6. Inspections and maintenance

6.1. Inspections

It is recommended that isolating switches be inspected once every five years to ensure trouble-free operation and:

- Each time the main contacts are replaced
- After switching on the isolating switch, there is a short circuit

During inspections, particular attention should be paid to:

- Condition of insulators (scratches, cracks, etc.)
- Condition of main contacts (dirt, traces of melting)
- Condition of the screw connections of the connector (cable connections, connections to the drive, attachment of the device to the supporting structure)
- Condition of the switch driving mechanism
- Condition of protective coatings

6.2. Maintenance

It is recommended to perform isolating switches maintenance after each inspection. Maintenance scope includes:

- Cleaning of insulators
- Cleaning the main contacts
- Lubricating the main contacts with conductive grease (acid-free)
- Tighten any loose screw connections
- Replacing damaged protective coatings (cold zinc spray)

CHAPTER 2

MV air cut-off switches

RN III SA 24/4 (K, S)
RUN III SA 24/4 (K, S)
RNp III SA 24/4 (K, S)
RUNp III SA 24/4 (K, S)
RNM III SA 24/4 (K, S)
RUNM III SA 24/4 (K, S)
RNMp III SA 24/4 (K, S)
RUNMp III SA 24/4 (K, S)
RNp III SA 24/4o (K, S)
RUNp III SA 24/4o (K, S)
RNM III SA 24/4o (K, S)
RUNM III SA 24/4o (K, S)
RNMp III SA 24/4o (K, S)
RUNMp III SA 24/4o (K, S)

1. Characteristics and intended use

The subject of the study is the construction documents of three-pole cut-off switches and overhead cut-off and earthing switches manufactured by Alpar Ltd.

The switches are built on a common frame for horizontal installation (RN, RUN) or for vertical installation (RNp, RUNp) and on one supporting bar (RNM, RUNM). Each pole of the cut-off switch consists of two stand-off insulator, one insulator is fixed and the other is movable. Electric current path are installed on the insulators.

Switch cut-off switches can be equipped with porcelain, composite or silicone insulators. Overhead switches of the RN type (RUN) are used in power transmission networks with voltages of 15, 20 and 30 kV. They are designed to connect and disconnect transmission lines with a load of up to 25 A. Cut-off switches with an installed earthing switch (RUN) additionally ground the lines in the disconnected part.

RN (RUN) III SA 24/4 switch cut-off switches can also be used in branch lines supplying one or more transformer stations, because in the open position, they create a visible and safe insulating break, thus meeting the requirements for insulating switches.

RN III SA 24/4 (K, S)
 RUN III SA 24/4 (K, S)
 RNp III SA 24/4 (K, S)
 RUNp III SA 24/4 (K, S)
 RNM III SA 24/4 (K, S)
 RUNM III SA 24/4 (K, S)
 RNMp III SA 24/4 (K, S)
 RUNMp III SA 24/4 (K, S)
 RNp III SA 24/4o (K, S)
 RUNp III SA 24/4o (K, S)
 RNM III SA 24/4o (K, S)
 RUNM III SA 24/4o (K, S)
 RNMp III SA 24/4o (K, S)
 RUNMp III SA 24/4o (K, S)

2. Technical data

Cut-off and cut-off-earthing switches have been tested. The tests have been carried out according to the following standard requirements:

PN-EN IEC 62271-102:2018-10 High voltage switchgear and control equipment

Part 1: Common provisions

PN-EN 62271-103:2011 High voltage switchgear and control equipment

Part 103: Switches with a rated voltage higher than 1 kV up to and including 52 kV

PN-EN IEC 62271-102:2018-10 High voltage switchgear and control equipment

Part 102: High voltage alternating current cut off and earthing switches

Type - version	RN(M)(p) i RUN(M)(p)	
Rated voltage U_r	24kV	
Rated frequency f_r / number of phases	50Hz / 3	
Rated withstand voltage at power frequency U_d	To the ground and interphase	50 kV
	A safe isolation break	60 kV
Rated lightning impulse withstand voltage U_p (1,2/50 μ s)	To the ground and interphase	125 kV
	A safe isolation break	145 kV
Rated continuous current I_r	400 A	
Rated short-time withstand current I_k / t_k	16 kA / 1 s	
Rated peak withstand current I_p	40 kA	
Rated breaking current in a circuit with low inductance I_{load}	20 A	
Rated breaking current in the ring network circuit I_{loop}	20 A	
Rated breaking current for charging overhead lines I_c	2 A	
Rated breaking current of cable charging I_{cc}	16 A	
Rated breaking current for earth fault I_{ef1}	48 A	
Rated breaking current for charging cables and overhead lines under earth fault conditions I_{ef2}	27 A	
Electrical/mechanical durability class of the cut-off switch (5000 C-O cycles)	E3 / M2	
Motor/manual drive (type)	NEA-__ / NRA(u) / NRMA(u)	
Rated short-time withstand current of the earthing switch I_{ke} / t_k	16 kA / 1 s	
Rated peak withstand current of the earthing switch I_{pe}	40 kA	
Rated short-circuit making current of the earthing switch I_{ma}	2,5 kA	
Rated short-circuit making current of the cut-off switch I_{ma}	2,5 kA	
Classification of earthing switch for short-circuit switching	E2	
Classification of the switch for short-circuit switching	E2	
Operating conditions: ambient temperature	-40°C to +40°C	
Working conditions: installation height above sea level	< 1000 m	

3. Manufacturer's code of the isolating or cut-off switch

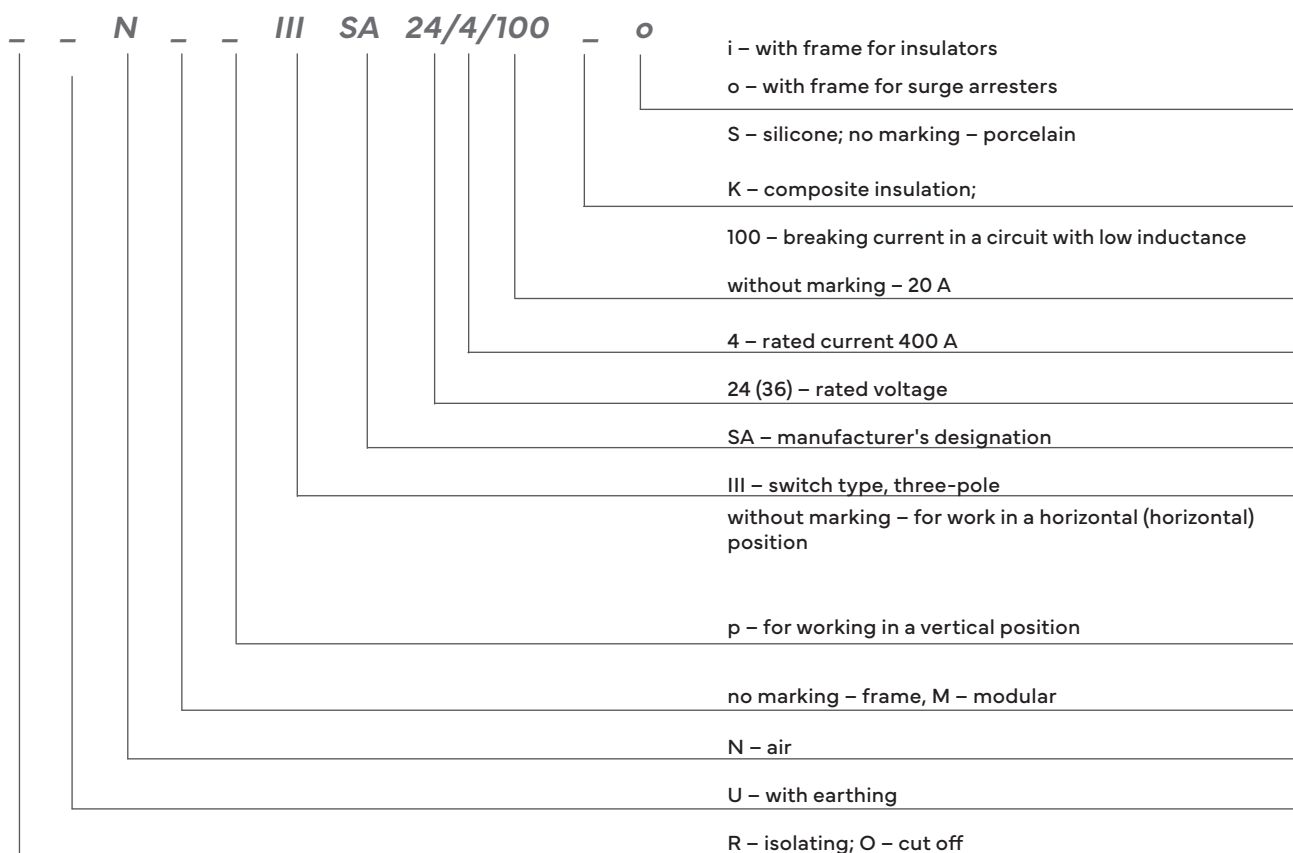

Marking examples:

OUN III SA 24/4

– three-pole overhead isolating-earthing switch 24 kV / 400 A with porcelain insulation

RUNMp III SA 24/4

– outdoor modular vertical three-pole cut off-earthing switch 24 kV / 400 A with porcelain insulation

ONp III SA 24/4 S

– vertical three-pole overhead isolating switch 24 kV / 400 A with silicone insulation

RUNM III SA 24/4 Ko

– outdoor modular three-pole cut-off-earthing switch 24 kV / 400 A with composite insulation and structure for surge arresters

RNM III SA 24/4/100S

– three-pole modular overhead cut-off switch 24 kV / 400 A / 100 A with silicone insulation

4. Types and structure

4.1. Cut-off switches built on a frame - horizontal installation on a pole.

The RN (RUN) III SA 24/4 type outdoor cut-off switches have a three-polar structure with a common base (frame) and a common drive for all poles. Each pole of the cut-off switch is built on two support insulators. One insulator is attached to the base (frame) and the other to the bearing-mounted movable beam. This structure ensures simultaneous closing and opening of all poles.

Standard cut-off switches are made of porcelain insulators. Additionally, they can be equipped with insulators:

- RN (RUN) III SA 24/4 K – composite
- RN (RUN) III SA 24/4 S – silicone

At the customer's request, other insulators with a valid certificate can be used.

The current path of each pole consists of main contacts and auxiliary (snap) contacts. These elements are attached to support holder placed directly on the support insulators. The main current path consists of a flat fixed contact and two profiled moving contacts screwed together. The moving contacts of the current path have been profiled in a shape that ensures trouble-free self-guidance and a large contact surface. Additionally, the mounting of the movable contacts has technical clearance, thanks to which the contact surface between the movable contacts and the fixed contact (or earthing switch contact) is optimal. As standard, the main contacts are made of flat copper, protected against corrosion by tinning, and can additionally be silver-plated.

The auxiliary (snap) contact consists of a driver and a spring. The driver is made of galvanized steel sheet and the snap contact spring is made of spring stainless steel.

Each movable pole of the cut-off switch is standardly equipped with a movable joint with a current terminal of 16-95 mm², on request 120 mm². The joint is designed to prevent the cable or power cord from breaking. A rope or wire with a cross-section of up to 95 (120) mm² can be connected to the terminal. To ensure an optimal current flow path, the connection terminal is connected to the main contact via a flexible copper connector. A current terminal is used to connect a cable or power cable from the side of the permanent contact, which also allows the connection of a cable with a cross-section of up to 95 (120) mm².

The frame of the cut-off switch is made of closed profiles and cold-formed sections. Corrosion protection is provided by a zinc coating made by immersion. RN (RUN) III SA 24/4 cut-off switches are designed for horizontal mounting on all standard power structures used in the professional power industry.

The cut-off switch is controlled by using a manual drive type NRA(u) or a motor drive NEA. The drives are coupled to the switch's drive mechanism using 2 M10 screws.

Basic solutions

- RN III SA 24/4 type cut-off switch

03-003
RN III SA 24/4

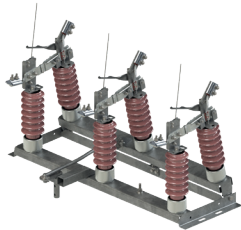

03-007
RN III SA 24/4K

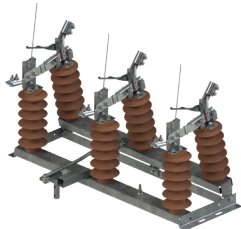

03-011
RN III SA 24/4S



- RUN III SA 24/4 type cut-off-earthing switch

03-004
RUN III SA 24/4

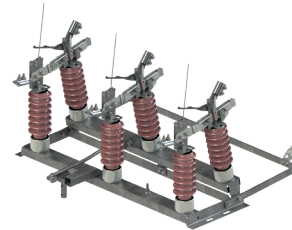

03-008
RUN III SA 24/4K

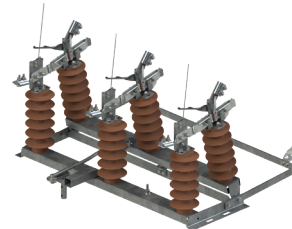

03-012
RUN III SA 24/4S

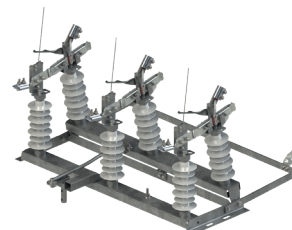

Basic dimensions

○ RN III SA 24/4 type cut-off switch

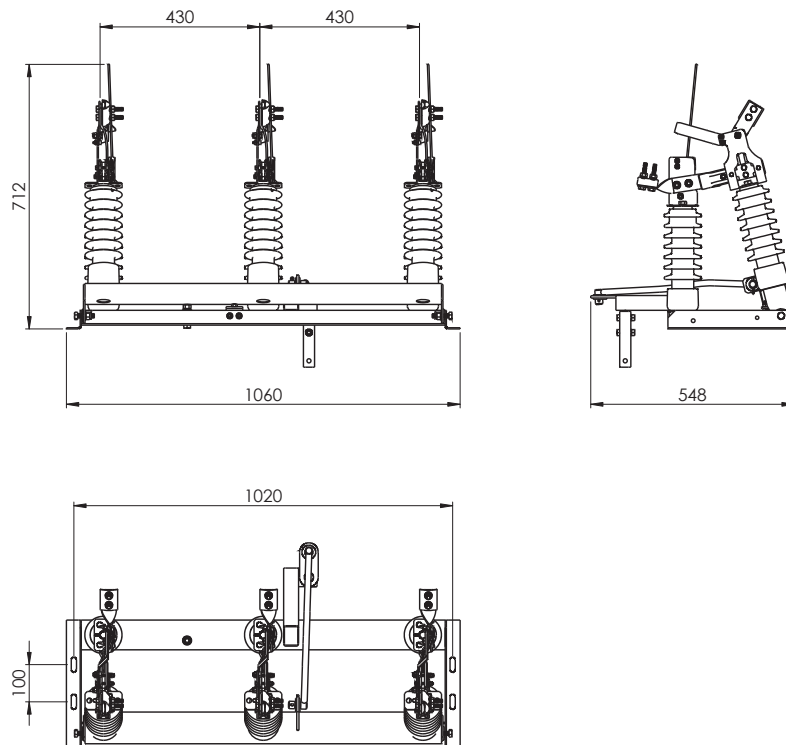

○ RUN III SA 24/4 type cut-off-earthing switch

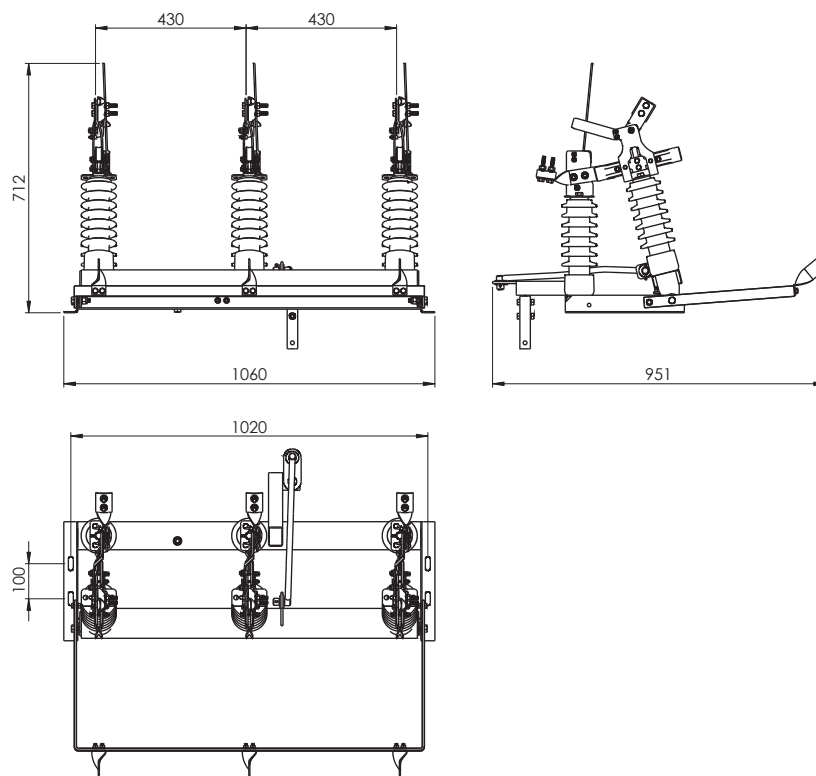

4.2. Cut-off switches built on a frame - vertical installation on a pole.

Outdoor cut-off switches type RNp (RUNp) III SA 24/4 have a three-pole design with a common base (frame) and a common drive for all poles. An integral part of each vertical cut-off switch is the structure fastening to the pole leg. Each pole of the cut-off switch is built on two support insulators. One insulator is attached to the base (frame) and the other to the movable beam with bearings. This structure ensures simultaneous closing and opening of all poles.

Standard cut-off switches are made of porcelain insulators. Additionally, they can be equipped with insulators:

- RNp (RUNp) III SA 24/4 K – composite
- RNp (RUNp) III SA 24/4 S – silicone

At the customer's request, other insulators with a valid certificate can be used.

The current path of each pole consists of main contacts and auxiliary (snap) contacts. These elements are mounted on support holder placed directly on the support insulators.

The main current path consists of a flat fixed contact and two profiled moving contacts screwed together. The moving contacts of the current path have been profiled to ensure trouble-free self-guidance and a large contact surface. Additionally, the mounting of the movable contacts has a technical clearance, thanks to which the contact surface of the movable contacts with the fixed contact (or earthing switch contact) is optimal. As standard, the

main contacts are made of flat copper, protected against corrosion by tin plating, and can also be silver-plated.

The auxiliary (snap) contact consists of a driver and a spring. The driver is made of galvanized steel sheet and the snap contact spring is made of spring stainless steel.

Each movable pole of the cut-off switch is standardly equipped with a movable joint with a current terminal of 16-95 mm², on request 120 mm². The joint is designed to prevent the cable or power cord from breaking. A rope or wire with a cross-section of up to 95 (120) mm² can be connected to the terminal. To ensure an optimal current flow path, the connection terminal is connected to the main contact via a flexible copper connector. A current terminal is used to connect a cable or power cable from the side of the permanent contact, which also allows the connection of a cable with a cross-section of up to 95 (120) mm².

The frame of the cut-off switch is made of closed profiles and cold-formed sections. Corrosion protection is provided by a zinc coating made by immersion. RNp (RUNp) III SA 24/4 cut-off switches are designed to be mounted directly on the pole leg.

The cut-off switch is controlled by using a manual drive type NRA(u) or a motor drive NEA. The drives are coupled to the switch's drive mechanism using 2 M10 screws.

Basic solutions

○ RNp III SA 24/4 type cut-off switch

03-035
RNp III SA 24/4

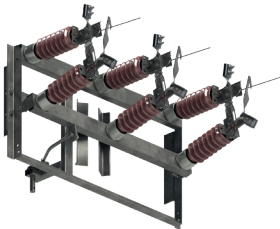

03-039
RNp III SA 24/4K

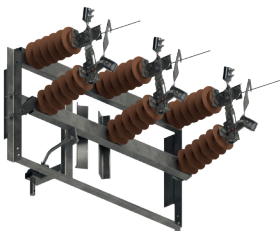

03-043
RNp III SA 24/4S

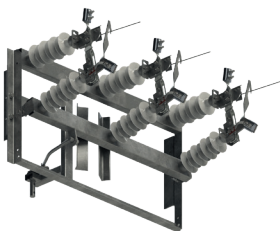

○ RUNp III SA 24/4 type cut-off-earthing switch

03-036
RUNp III SA 24/4

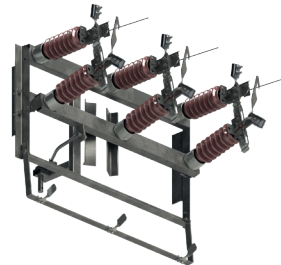

03-040
RUNp III SA 24/4K

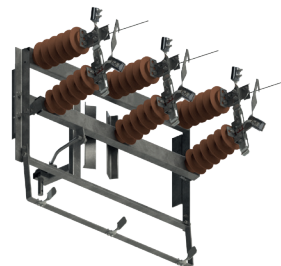

03-044
RUNp III SA 24/4S

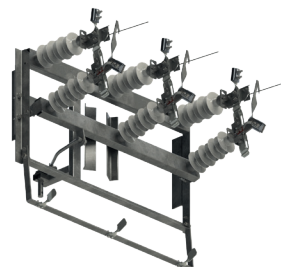

Basic dimensions

○ *RNp III SA 24/4 type cut-off switch*

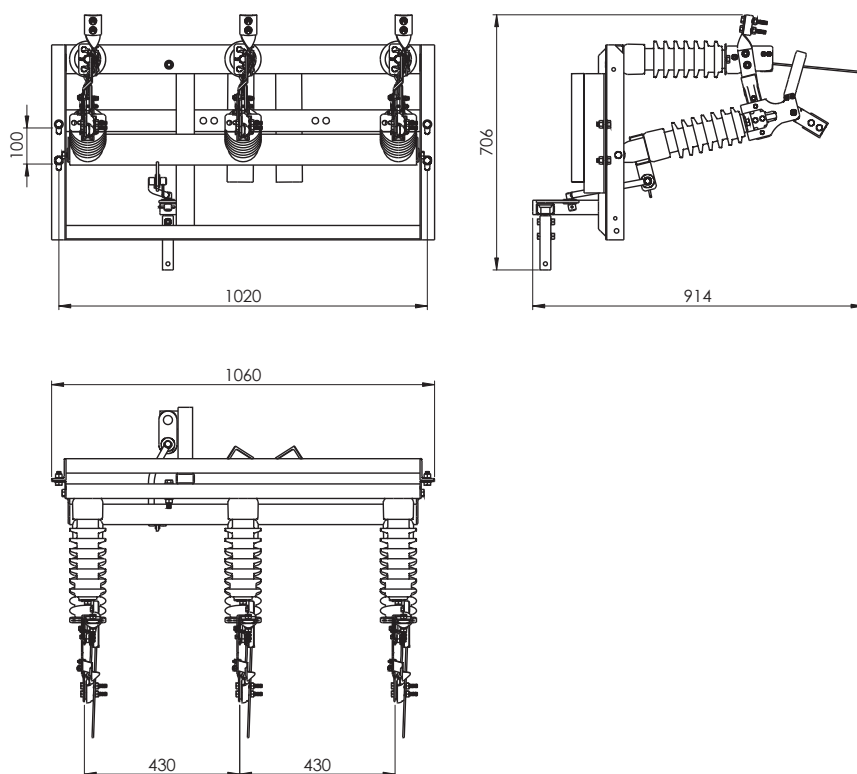

○ *RUNp III SA 24/4 type cut-off-earthing switch*

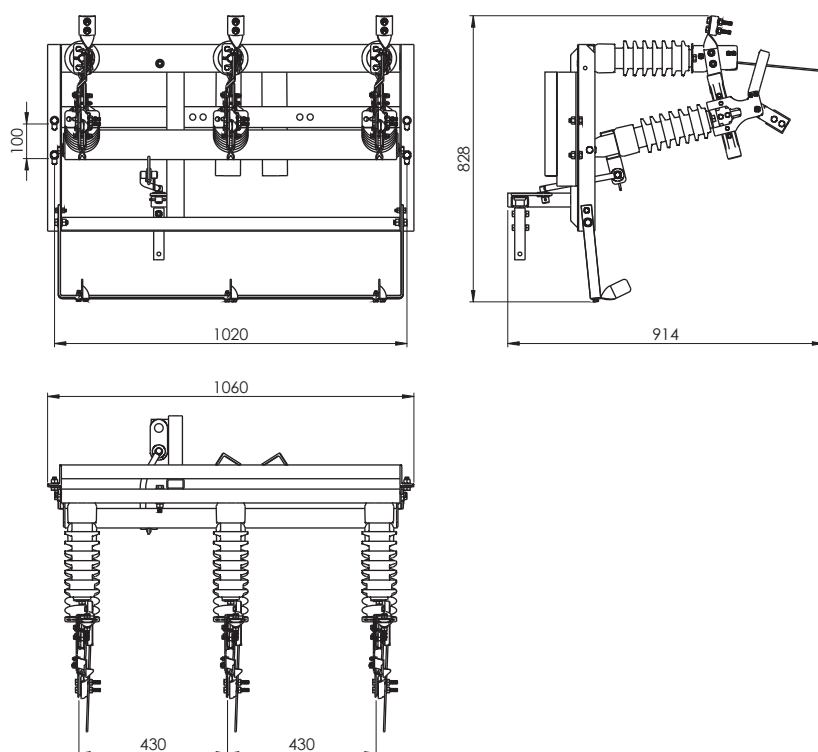

4.3. Modular cut-off switches – horizontal installation on a pole.

The modular structure of RNM (RUNM) III SA 24/4 cut-off switches allows you to independently set the poles to each other while maintaining minimum, safe distances.

These switches can be installed at the top (above the pole conductors) and on the pole leg in a horizontal position. When ordering a modular switch (disconnecter-earthing switch) intended for installation on the top of a pole, please provide the type of structure to which the switch is to be attached (see: **Booklet 4: Fixing switches in overhead MV lines**). When ordering a modular switch (cut-off-earthing switch) intended for installation on a pole leg, please provide the top diameter of the spun pole.

RNM (RUNM) III SA 24/4 outdoor cut-off switches have an asymmetric three-pole structure with a common support beam and a common drive for all poles. Each pole of the cut-off switch is built on two support insulators. One insulator is permanently attached to the structure, the other is attached to a movable structure with bearings. The movable structures of all three poles are connected by one profile. The handle of the switch's drive mechanism is attached to the profile; this design ensures simultaneous closing and opening of all poles.

Modular cut-off switches are usually built on porcelain insulators. Additionally, they can be equipped with insulators:

- RNM (RUNM) III SA 24/4K – composite
- RNM (RUNM) III SA 24/4S – silicone

At the customer's request, other insulators with a valid certificate can be used.

The current path of each pole consists of main and auxiliary (snap) contacts. These elements are attached to support holder placed directly on the support insulators.

The main current path consists of a flat fixed contact and two profiled moving contacts screwed together. The moving contacts of the current path have been profiled to ensure trouble-free self-guidance and a large contact surface. Additionally, the mounting of the movable contacts has a technical clearance, thanks to which the contact surface of the movable contacts with the fixed contact (or earthing switch contact) is optimal. As standard, the main contacts are made of flat copper, protected against corrosion by tin plating, and can also be silver-plated. The auxiliary (snap) contact consists of a driver and a spring. The driver is made of galvanized steel sheet and the snap contact spring is made of spring stainless steel. Each movable pole of the cut-off switch is equipped with a movable joint with a 16-95 mm² current terminal or 120 mm² on request. The joint is designed to prevent the cable or power cord from breaking.

To ensure an optimal current flow path, the connection terminal is connected to the main contact via a flexible copper connector. A feeder clamp is used to connect a cable or power cable from the side of the permanent contact, which also allows you to connect a cable with a cross-section of up to 95 (120) mm².

Corrosion protection is provided by a zinc coating made by immersion. The disconnecter is controlled by using a manual drive type NRA(u) or a motorized drive NEA. The drives are coupled to the drive mechanism of the switch using 2 M10 screws.

Basic solutions

○ RNM III SA 24/4 type cut-off switch

03-051
RNM III SA 24/4

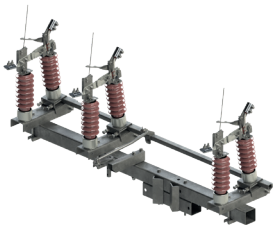

03-055
RNM III SA 24/4K



03-059
RNM III SA 24/4S

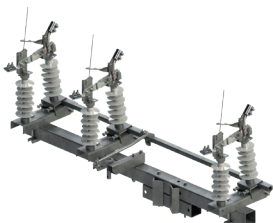

○ RUNM III SA 24/4 type cut-off-earthing switch

03-052
RUNM III SA 24/4

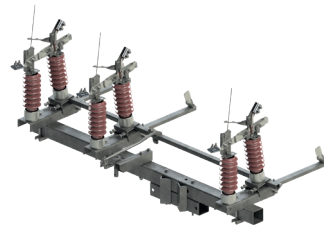

03-056
RUNM III SA 24/4K

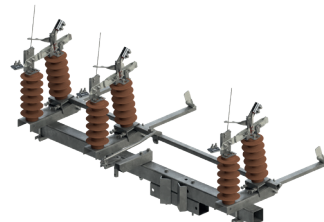

03-060
RUNM III SA 24/4S

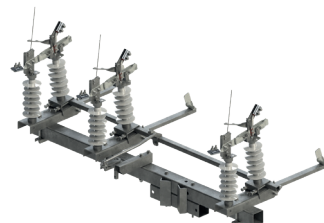

Basic dimensions

- RNM III SA 24/4 type cut-off switch

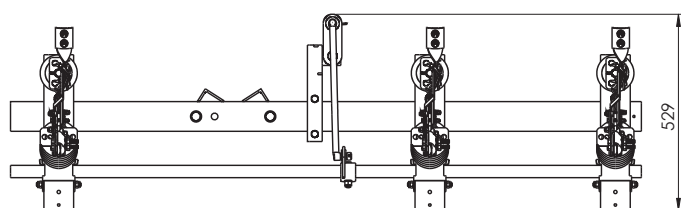
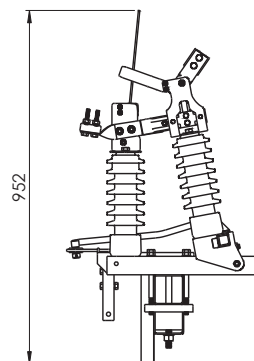
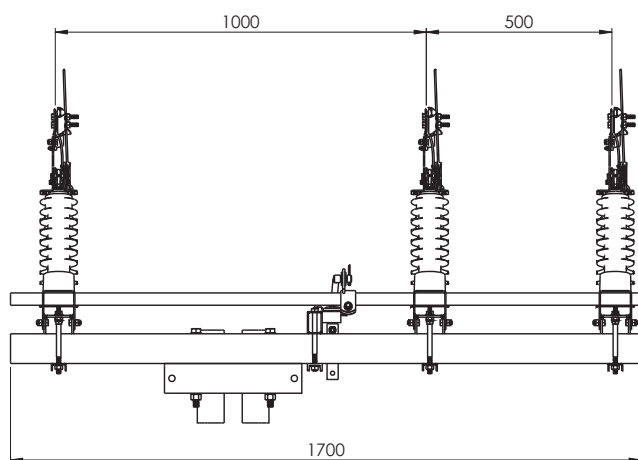

- RUNM III SA 24/4 type cut-off-earthing switch

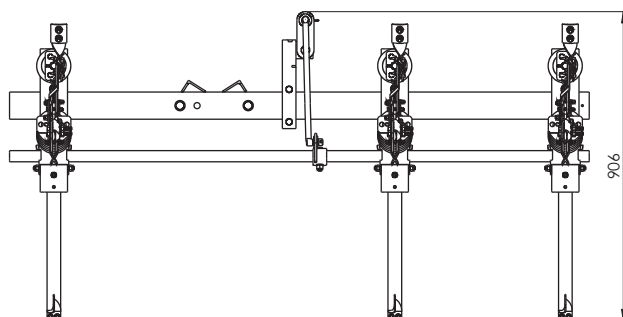
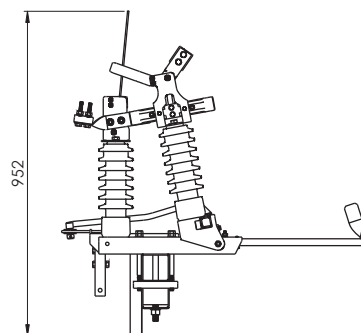
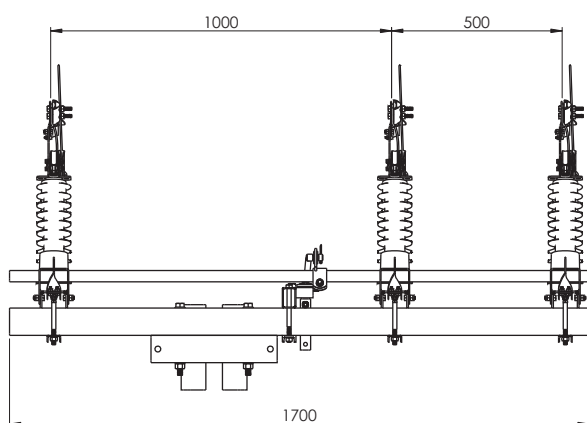

4.4. Modular cut-off switches – vertical installation on a pole.

The modular structure of the RNMP (RUNMp) III SA 24/4 cut-off switch allows you to independently set the poles to each other while maintaining minimum, safe distances.

These switches can only be installed on a pole leg in a vertical position. When ordering a modular cut-off switch (cut-off and earthing switch) intended for installation on a pole leg, please provide the top diameter of the spun pole. Outdoor cut-off switch type RNMP (RUNMp) III SA 24/4 have an asymmetric three-pole structure with a common support beam and a common drive for all poles. Each pole of the cut-off switch is built on two support insulators. One insulator is permanently attached to the structure, the other is attached to a movable structure with bearings. The movable structures of all three poles are connected by one profile. The handle of the switch's drive mechanism is attached to the profile; this design ensures simultaneous closing and opening of all poles.

Modular cut-off switches are usually built on porcelain insulators. Additionally, they can be equipped with insulators:

- RNM (RUNM) III SA 24/4K – composite
- RNM (RUNM) III SA 24/4S – silicone

At the customer's request, other insulators with a valid certificate can be used.

The current path of each pole consists of main and auxiliary (snap) contacts. These elements are attached to support holder placed directly on the support insulators.

The main current path consists of a flat fixed contact and two profiled moving contacts screwed together. The moving contacts of the current path have been profiled to ensure trouble-free self-guidance and a large contact surface. Additionally, the mounting of the movable contacts has a technical clearance, thanks to which the contact surface of the movable contacts with the fixed contact (or earthing switch contact) is optimal. As standard, the main contacts are made of flat copper, protected against corrosion by tinning, and can additionally be silver-plated. The auxiliary (snap) contact consists of a driver and a spring. The driver is made of galvanized steel sheet and the snap contact spring is made of stainless steel spring. Each movable pole of the cut-off switch is equipped with a movable joint with a current terminal of 16-95mm², on request 120mm². The joint is designed to prevent the cable or power cord from breaking.

To ensure an optimal current flow path, the connection terminal is connected to the main contact via a flexible copper connector. A feeder clamp is used to connect a cable or power cable from the side of the permanent contact, which also allows the connection of a cable with a cross-section of up to 95 (120) mm².

Corrosion protection is provided by a zinc coating made by immersion. The cut-off switch is controlled by using a manual drive type NRA(u) or a motor drive NEA. The drives are coupled to the switch driving mechanism using 2 M10 screws.

Basic solutions

○ RNMP III SA 24/4 type cut-off switch

03-019
RNMP III SA 24/4

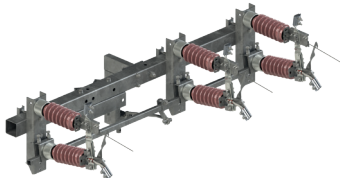

03-023
RNMP III SA 24/4K

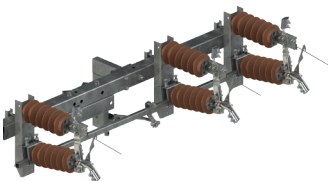

03-027
RNMP III SA 24/4S

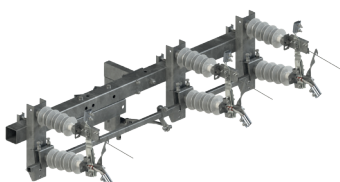

○ RUNMp III SA 24/4 type cut-off-earthing switch

03-020
RUNMp III SA 24/4

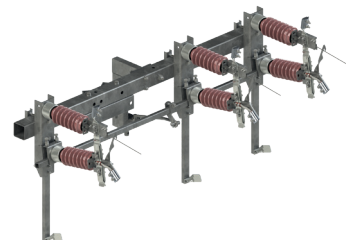

03-024
RUNMp III SA 24/4K

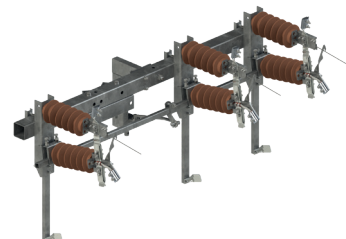

03-028
RUNMp III SA 24/4S

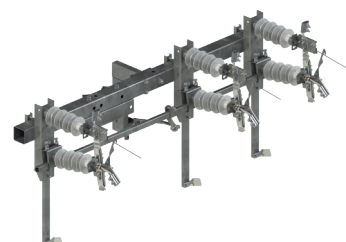

Basic dimensions

- RNMp III SA 24/4 type cut-off switch

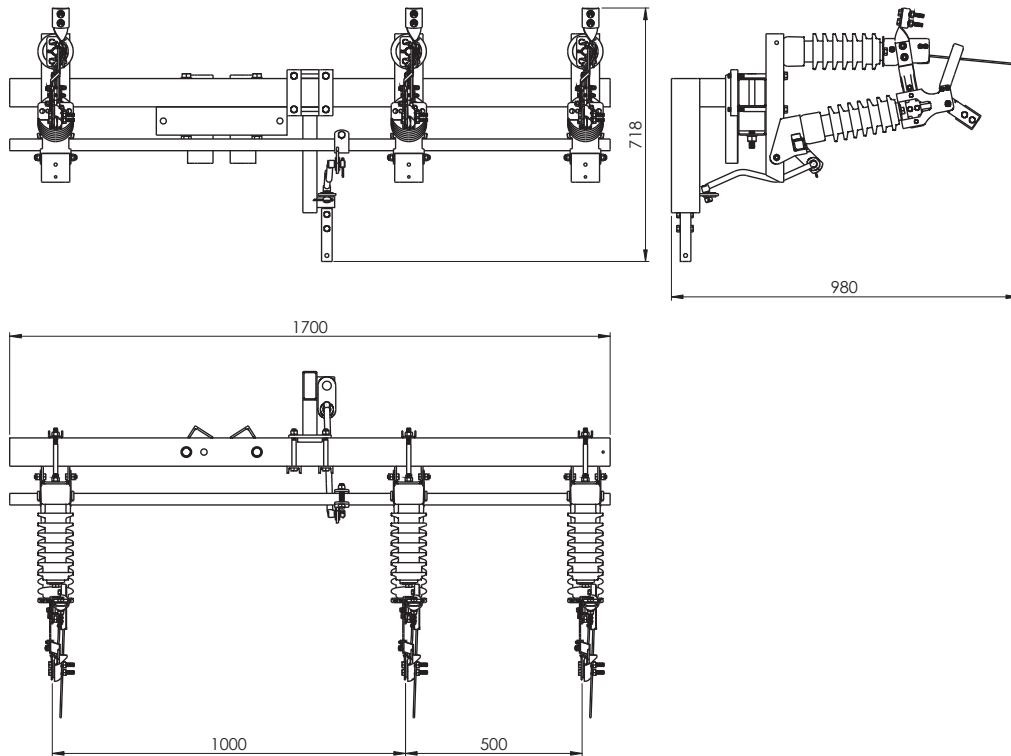

- RUNMp III SA 24/4 type cut-off-earthing switch

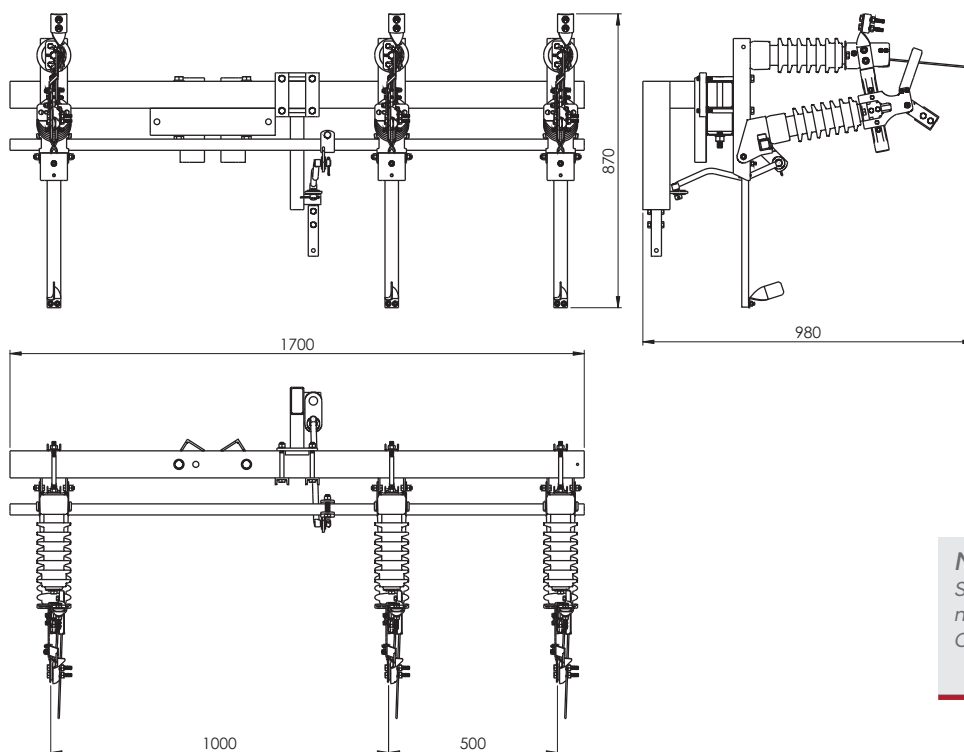

NOTE!
Switches with left-hand movement.
Opening from left to right.

4.5. Frame cut-off switches with their own disconnecter with a frame/ construction ready for MV surge arresters - vertical installation on a pole.

Outdoor cut-off switches type RNp (RUNp) III SA 24/4o have a three-pole design with a common base (frame) and a common drive for all poles. An integral part of each vertical cut-off switch is the structure attaching it to the pole leg. Each pole of the cut-off switches is built on two support insulators. One insulator is attached to the base (frame) and the other to the bearing-mounted movable beam. This construction ensures the simultaneous closing and opening of all poles.

Standard cut-off switches are made of porcelain insulators. Additionally, they can be equipped with insulators:

- RNp (RUNp) III SA 24/4Ko – composite
- RNp (RUNp) III SA 24/4So – silicone

At the customer's request, other insulators with a valid certificate can be used.

The current path of each pole consists of main contacts and auxiliary (snap) contacts. These elements are mounted on support holder placed directly on the support insulators. The main current path consists of a flat permanent contact and two profiled contacts twisted together. The moving contacts of the current path have been profiled in a shape that ensures trouble-free self-guidance and a large contact surface. Additionally, the mounting of the movable contacts has a technical clearance, thanks to which the contact surface of the movable contacts with the fixed contact (or earthing switch contact) is optimal. As standard, the main contacts are made of flat copper, protected against corrosion by tinning, and can additionally be silver-plated.

The auxiliary (snap) contact consists of a driver and a spring. The driver is made of galvanized steel sheet and the snap contact spring is made of stainless steel spring. Each movable pole of the cut-off switch is standardly equipped with a movable joint with a feeder clamp of 16-95 mm², on request 120 mm². The joint is designed to prevent the cable or power cord from breaking.

An LGY bridge with a copper mounting plate is factory-installed to the current terminal. The necessary holes are made in the mounting plate to assemble the bridge with a surge arrester and a cable header tip.

To ensure an optimal current flow path, the connection terminal is connected to the main contact via a flexible copper connector. A feeder clamp is used to connect a cable or power cable from the side of the permanent contact, which also allows you to connect a cable with a cross-section of up to 95 (120) mm². The frame of the cut-off switch is made of closed profiles and cold-formed sections. Corrosion protection is provided by a zinc coating made by immersion. A frame for surge arresters or support insulators is standardly attached to the frame of the cut-off switches - so there is no need to install an additional structure for the surge arresters. This solution provides more space on the pole and reduces implementation time and investment costs.

The cut-off switch is controlled by using a manual drive type NRA(u) or a motor drive NEA.

Basic solutions

○ RNp III SA 24/4o type cut off switch

03-035.1
RNp III SA 24/4o

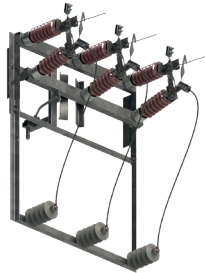

03-039.1
RNp III SA 24/4Ko

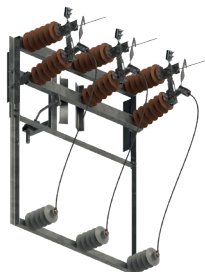

03-043.1
RNp III SA 24/4So

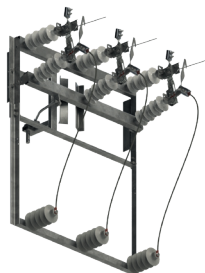

○ RUNp III SA 24/4o type cut off-earthing switch

03-036.1
RUNp III SA 24/4o

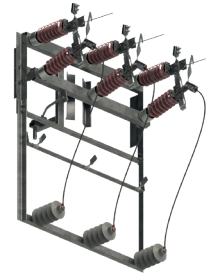

03-040.1
RUNp III SA 24/4Ko

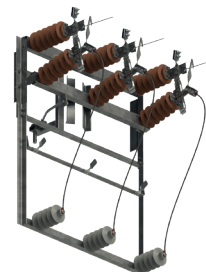

03-044.1
RUNp III SA 24/4So

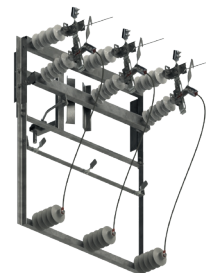

Basic dimensions

○ RNp III SA 24/4o type cut-off switch

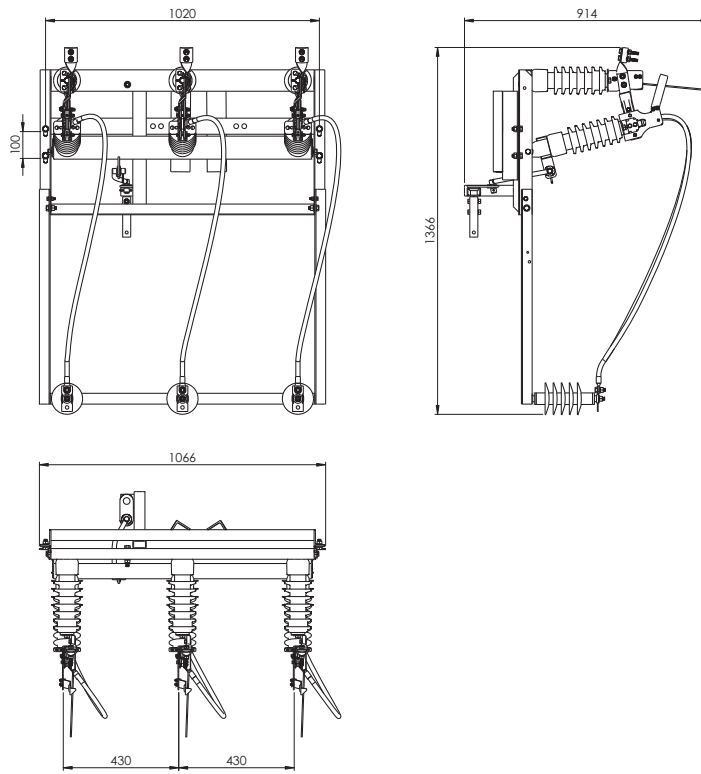

NOTE!
Surge arresters or support insulators are not standardly included in the price of the product!

○ RUNp III SA 24/4o type cut off-earthing switch

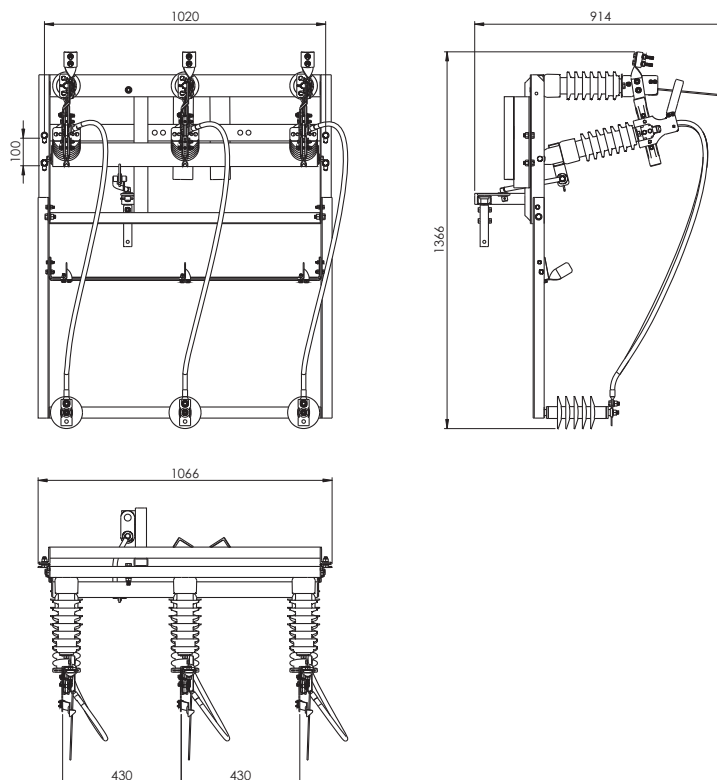

4.6. Modular cut-off switches with with construction ready for MV surge arresters - horizontal installation on a pole.

The modular structure of the RNM (RUNM) III SA 24/4o cut-off switch allows you to independently set the poles to each other, maintaining minimum, safe distances.

These switches can be installed at the top (above the pole conductors) and on the pole leg in a horizontal position. When ordering a modular switch (cut-off-earthing switch) intended for installation on the top of a pole, please provide the type of structure to which the switch is to be attached (see: **Booklet 4: Fixing switches in overhead MV lines**). When ordering a modular switch (cut-off switch-earthing switch) intended for installation on a pole leg, please provide the top diameter of the spun pole.

RNM (RUNM) III SA 24/4o outdoor cut-off switches have an asymmetric three-pole structure with a common support beam and a common drive for all poles. Each pole of the cut-off switch is built on two support insulators. One insulator is attached to the structure permanently, the other is attached to the movable structure with bearings. The movable structures of all three poles are connected by one profile. The handle of the switch driving mechanism is attached to the profile; this structure ensures simultaneous closing and opening of all poles.

Modular cut-off switches are usually built on porcelain insulators. Additionally, they can be equipped with insulators:

- RNM (RUNM) III SA 24/4Ko – composite
- RNM (RUNM) III SA 24/4So – silicone

The current path of each pole consists of main and auxiliary (snap) contacts. These elements are attached to support holder placed directly on the support insulators.

The main current path consists of a flat fixed contact and two profiled moving contacts screwed together.

The moving contacts of the current path have been profiled in a shape that ensures trouble-free self-guidance and a large contact surface. Additionally, the mounting of the movable contacts has a technical clearance, thanks to which the contact surface between the movable contacts and the fixed contact (or earthing switch contact) is optimal. As standard, the main contacts are made of copper flat bar, protected against corrosion by tinning, and can additionally be silver-plated. The auxiliary (snap) contact consists of a driver and a spring. The driver is made of galvanized steel sheet and the snap contact spring is made of spring stainless steel.

Each movable pole of the cut-off switch is equipped with a movable joint with a feeder clamp of 16-95 mm², on request 120 mm². The joint is designed to prevent the cable or power cord from breaking. An LGY bridge with a copper mounting plate is factory-installed to the current terminal. The necessary holes are made in the mounting plate to assemble the bridge with the surge arrester and the cable head end. To ensure an optimal current flow path, the connection terminal is connected to the main contact via a flexible copper connector. A current terminal is used to connect a cable or power cable from the side of the permanent contact, which also allows the connection of a cable with a cross-section of up to 95 (120) mm². As standard, structures for surge arresters or support insulators are attached to the main beam of the cut-off switch - so there is no need to install an additional structure for surge arresters.

The cut-off switch is controlled by using a manual drive type NRA(u) or a motor drive NEA.

Basic solutions

○ RNM III SA 24/4o type cut-off switch

03-067
RNM III SA 24/4o

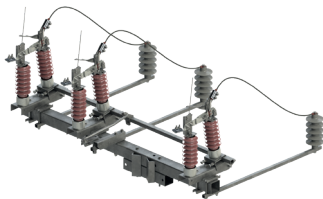

03-071
RNM III SA 24/4Ko

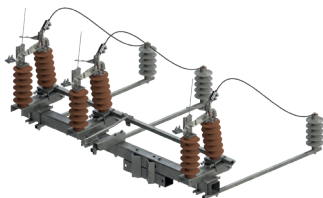

03-075
RNM III SA 24/4So

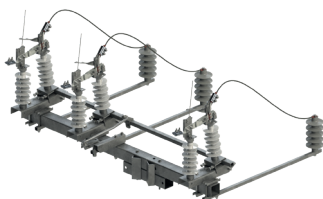

○ RUNM III SA 24/4o type cut-off-earthing switch

03-068
RUNM III SA 24/4o

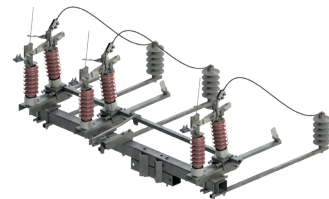

03-072
RUNM III SA 24/4Ko

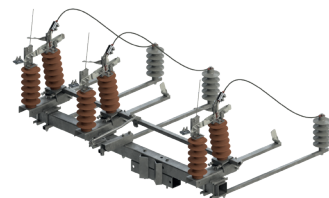

03-076
RUNM III SA 24/4So

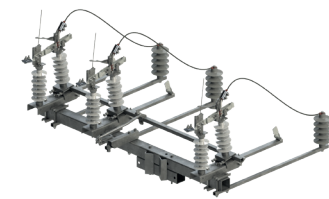

Basic dimensions

- RNM III SA 24/4o type cut-off switch

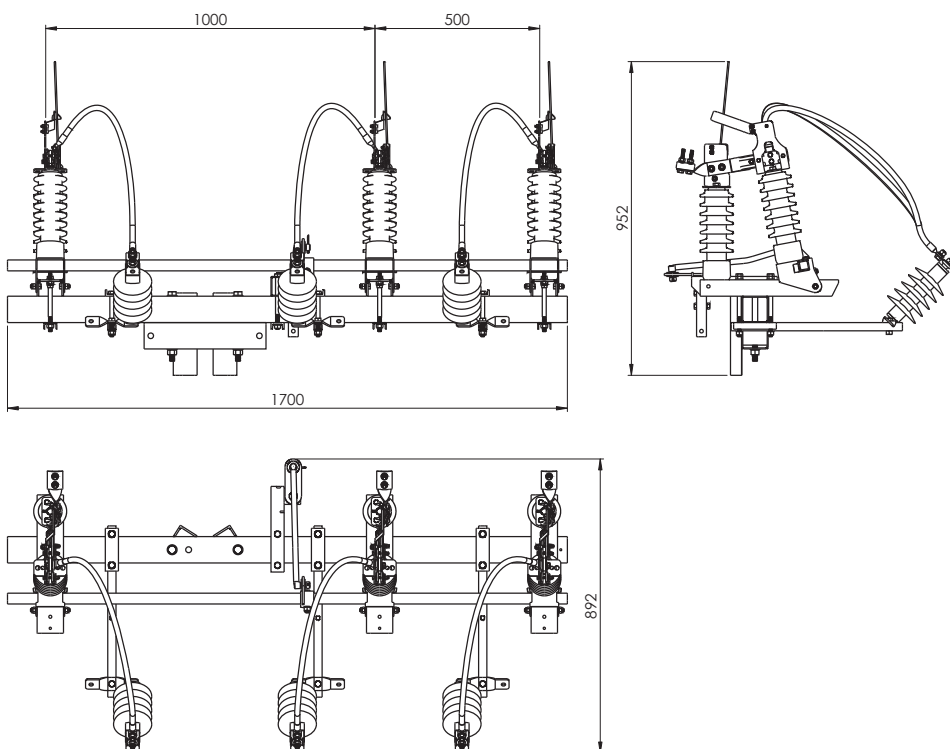

NOTE!
ALPAR's offer also includes cut off (RNM) and cut off-earthing switches (RUNM) with their own structure for mounting support insulators.

- RUNM III SA 24/4o type cut off-earthing switch

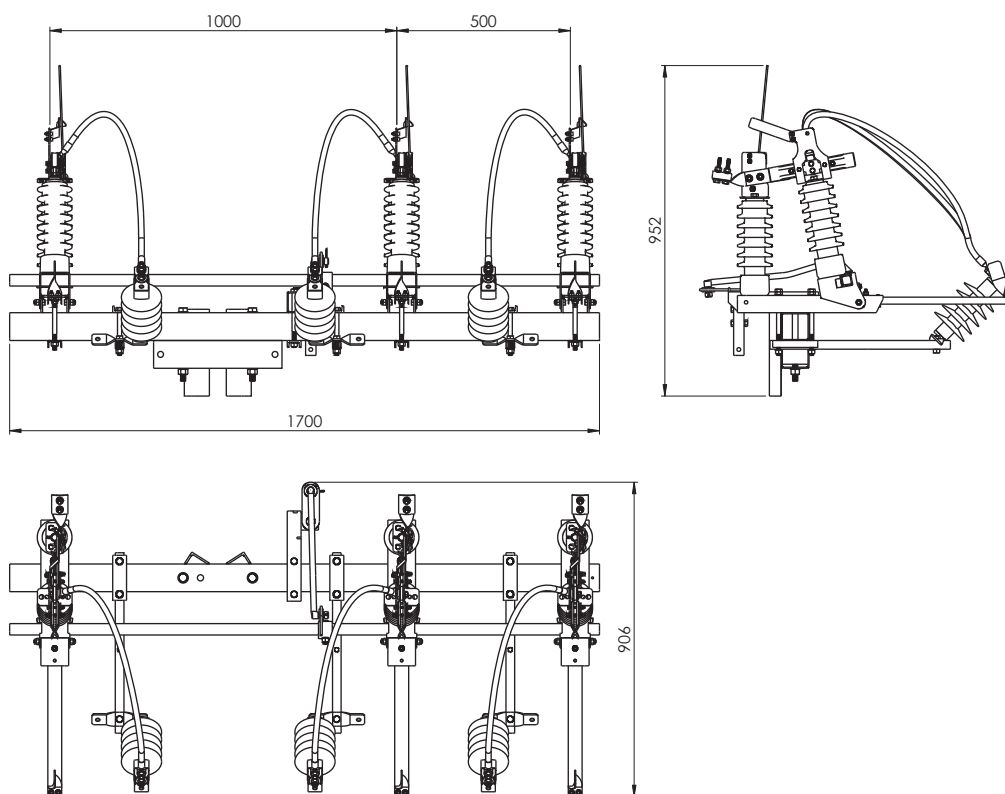

NOTE!
Surge arresters or post insulators are not standardly included in the price of the product!

4.7. Modular cut-off switches with with construction ready for MV surge arresters - vertical installation on a pole.

The modular structure of RNMP (RUNMP) III SA 24/4o cut-off switches allows for independent positioning of the poles relative to each other, maintaining minimum, safe distances. These switches can only be installed on a pole leg in a vertical position. When ordering a modular vertical cut-off switch (cut-off-earthing switch), please provide the top diameter of the spun pole.

Outdoor cut-off switch type RNMP (RUNMP) III SA 24/4o have an asymmetrical three-pole structure with a common support beam and a common drive for all poles. Each pole of the cut-off switch is built on two support insulators. One insulator is permanently attached to the structure, the other is attached to a movable structure with bearings. The movable structures of all three poles are connected by one profile. The handle of the connector's driving mechanism is attached to the profile; this structure ensures simultaneous closing and opening of all poles.

Modular cut-off switches are usually built on porcelain insulators. Additionally, they can be equipped with insulators:

- RNMP (RUNMP) III SA 24/4Ko – composite
- RNMP (RUNMP) III SA 24/4So – silicone

At the customer's request, other insulators with a valid certificate can be used.

The current path of each pole consists of main contacts and auxiliary (snap) contacts. These elements are attached to support holder placed directly on the support insulators. The main current path consists of a flat fixed contact and two profiled moving contacts screwed together. The moving contacts of the current path have

been profiled to ensure trouble-free self-guidance and a large contact surface.

Additionally, the mounting of the movable contacts has a technical clearance, thanks to which the contact surface between the movable contacts and the fixed contact (or earthing switch contact) is optimal. As standard, the main contacts are made of flat copper, protected against corrosion by tinning, and can additionally be silver-plated. The auxiliary (snap) contact consists of a driver and a spring. The driver is made of galvanized steel sheet and the snap contact spring is made of spring stainless steel.

Each movable pole of the cut-off switch is equipped with a movable joint with a 16-95 mm² current terminal or 120 mm² on request. The joint is designed to prevent the rope or power cord from breaking. An LGY bridge with a copper mounting plate is factory-installed to the current terminal. The necessary holes were made in the mounting plate to assemble the bridge with the surge arrester and the cable head end. To ensure an optimal current flow path, the connection terminal is connected to the main contact via a flexible copper connector. A feeder clamp is used to connect a cable or power cable from the side of the permanent contact, which also allows you to connect a cable with a cross-section of up to 95 (120) mm². As standard, structures for surge arresters or support insulators are attached to the main beam of the switch - so there is no need to install an additional structure for surge arresters. This solution provides more space on the pole and reduces implementation time and investment costs.

The cut-off switch is controlled by using a manual drive type NRA(u) or a motor drive NEA.

Basic solutions

○ RNMP III SA 24/4o type cut-off switch

03-079
RNMP III SA 24/4o

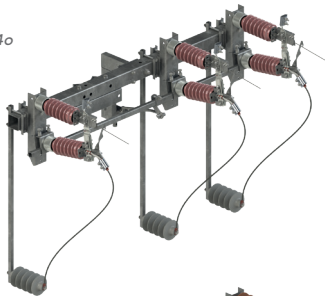

03-083
RNMP III SA 24/4Ko

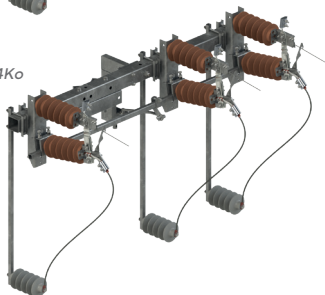

03-087
RNMP III SA 24/4So

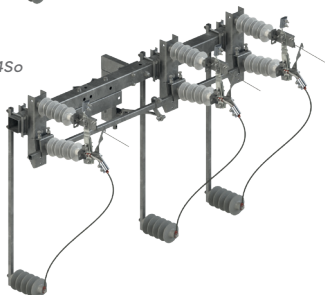

○ RUNMP III SA 24/4o type cut-off-earthing switch

03-080
RUNMP III SA 24/4o

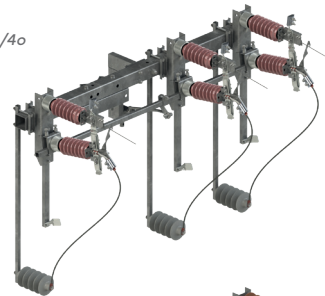

03-084
RUNMP III SA 24/4Ko

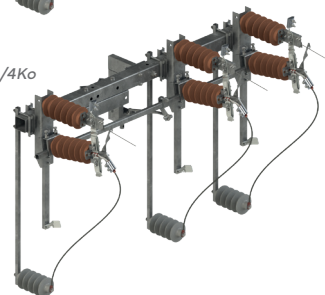

03-088
RUNMP III SA 24/4So

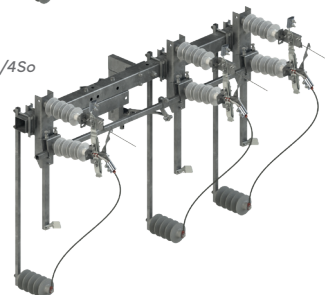

Basic dimensions

○ RNMp III SA 24/4o type cut-off switch

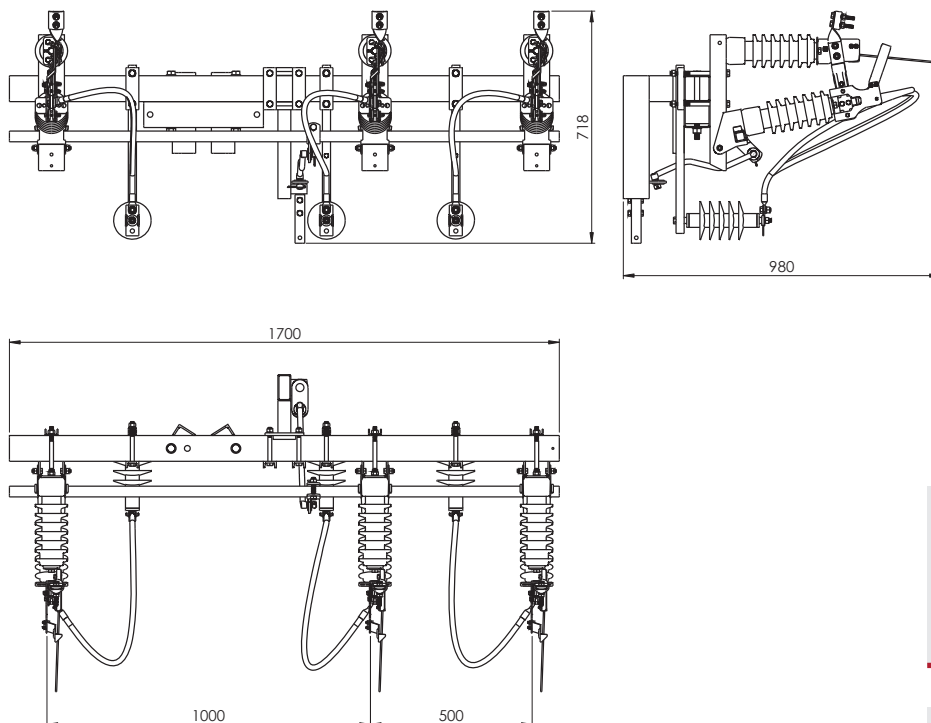

NOTE!
ALPAR's offer also includes cut off (RNM) and cut off-earthing switches (RUNM) with their own structure for mounting support insulators.

NOTE!
Surge arresters or support insulators are not standardly included in the price of the product!

○ RUNMp III SA 24/4o type cut off-earthing switch

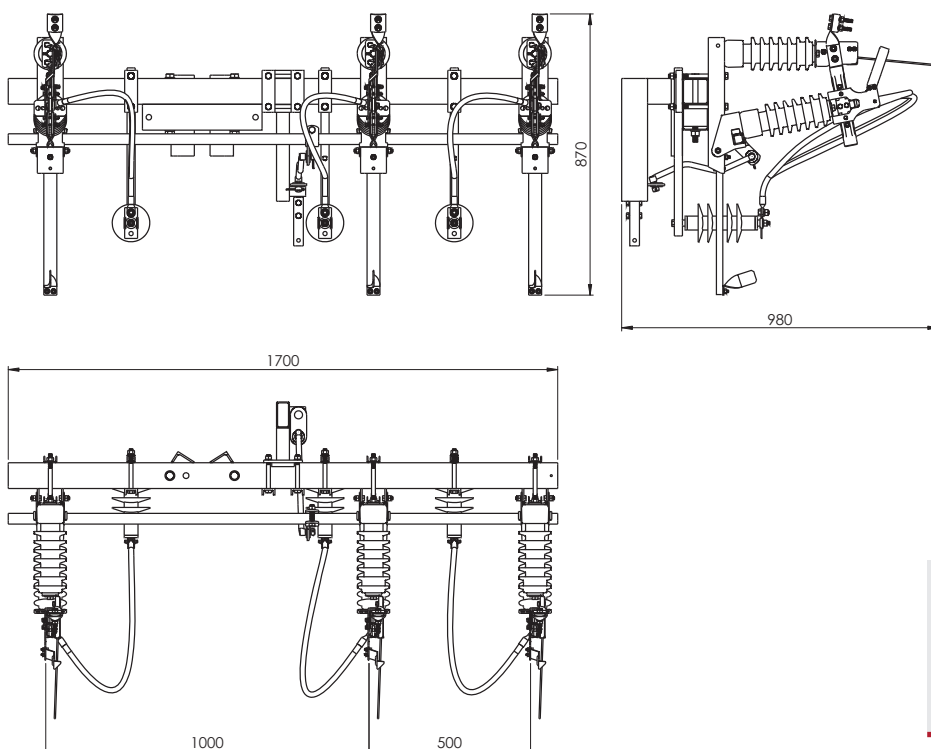

NOTE!
Switches with left-hand movement.
Opening from left to right.

5. Using the cut-off switches

Immediately after receiving the cut-off switch, check the compliance of the delivery with the order and the general condition of the cut-off switch.

The devices should be carried during unloading, loading and assembly by grasping only the base (beam).

NOTE!

It is unacceptable to grab the elements of the current circuit and the support insulators of the cut off switch.

The cut-off switches are delivered to the customer completely assembled and adjusted - always in the closed position. After unpacking, check whether the device has not suffered any mechanical damage during transport and whether the data on the rating plate are consistent.

When mounting the cut-off switch on a pole and coupling it with the NRA(u) and NRMA(u) manual drive, the device should be in the closed position. When installing the handwheel, the drive key should be on the right side in the closed position.

NOTE!

Does not apply to modular cut off switches operating in a vertical position (vertical). In this group of switches, the key should be on the left side.

6. Inspections and maintenance

6.1. Inspections

It is recommended that the cut-off switches be inspected once every five years to ensure trouble-free operation and:

- Each time the auxiliary contacts are replaced
- After switching on the disconnector, there is a short circuit

During inspections, particular attention should be paid to:

- Condition of insulators (scratches, cracks, etc.)
- Condition of main contacts (dirt, traces of melting)
- Condition of auxiliary contacts (traces of melting of the contact spring, attachment to the permanent contact cassette)
- Condition of the screw connections of the connector (cable connections, connections to the drive, attachment of the device to the supporting structure)
- Condition of the switch driving mechanism
- Condition of protective coatings

NOTE!

Installing a drive other than the NRA(u) and NRMA(u) type is possible after contacting the manufacturer.

As standard, the switches are designed to connect conductors with a cross-section of up to 95 mm². Before connection, it is recommended to clean the contact surfaces of the connecting elements (connection terminals) from any possible contamination and lubricate them with a thin layer of conductive grease (acid-free).

Before putting the switch into operation, check the condition of the device, correct coupling with the drive and correct operation. The switch should be visually inspected, checking the condition of the insulators (dirt, cracks, etc.) and the correct tightening of the screw connections - in particular the cable connections, the connection to the drive and the attachment of the apparatus to the supporting structure. Then perform several switching cycles, paying attention to the correct operation of the main contacts of the auxiliary contacts (setting when closing).

6.2. Maintenance

- It is recommended to perform maintenance of the switch after each inspection. Maintenance scope includes:
 - Cleaning the insulators
 - Cleaning the main and auxiliary contacts
 - Lubricating the main contacts with conductive grease (acid-free)
 - Tightening any loose screw connections
 - Replacing damaged protective coatings (cold zinc spray)

CHAPTER 3

***MV switch disconnectors with air interrupters
with switching current 100A***

RN III SA 24/4/100 (K, S)

RUN III SA 24/4/100 (K, S)

RNp III SA 24/4/100 (K, S)

RUNp III SA 24/4/100 (K, S)

RNM III SA 24/4/100 (K, S)

RUNM III SA 24/4/100 (K, S)

RNMp III SA 24/4/100 (K, S)

RUNMp III SA 24/4/100 (K, S)

1. Characteristics and intended use

The subject of the study is the construction documentation of three-pole cut-off switches and overhead cut-off and earthing switches manufactured by Alpar Ltd.

Cut-off switches are constructed in two basic types:

Frame – these are cut-off switches built on a common frame and intended for horizontal installation on typical steel structures (RN; RUN) or cut-off switches intended for vertical modular equipped with their own structure fastening to the pole leg (RNp; RUNp)

Modular – these are switches built on a common beam and intended for both horizontal and vertical installation, equipped with their own mounting structure to the pole leg or linear crossbars (RNM, RNMp; RUNM, RUNMP).

Each pole of the cut-off switch consists of two support insulators, one insulator is fixed and the other is movable. Current paths and special extinguishing chambers are installed on the insulators. The cut-off switches can be equipped with porcelain, composite or silicone insulators.

Overhead switches of the type RN (RUN) III SA 24/4/100 (K,S) and RNM (RUNM) III SA 24/4/100 (K,S) are used in power transmission networks with voltage of 15 and 20 kV. They are designed to connect and disconnect transmission lines with loads up to 100 A.

The cut-off switches with an installed earthing switch (RUN) additionally earth the lines in the disconnected part. RN (RUN) III SA 24/4 cut-off switches can also be used in branches supplying one or more transformer stations, because in the open position they create a visible and safe insulation break, thus meeting the requirements for insulating switches.

RN III SA 24/4/100 (K, S)
 RUN III SA 24/4/100 (K, S)
 RNp III SA 24/4/100 (K, S)
 RUNp III SA 24/4/100 (K, S)
 RNM III SA 24/4/100 (K, S)
 RUNM III SA 24/4/100 (K, S)
 RNMp III SA 24/4/100 (K, S)
 RUNMp III SA 24/4/100 (K, S)

2. Technical data

PN-EN 62271-1:2018-02 *High voltage switchgear and control equipment*
 Part 1: Common specification

IEC 62271-1:2007+AMD1:2011 *High-voltage switchgear and controlgear*
 Part 1: Common specification

PN-EN 62271-103:2011 *High voltage switchgear and control equipment*
 Part 103: Switches for rated voltages above 1 kV up to and including 52 kV

IEC 62271-103:2011 *High-voltage switchgear and controlgear*
 Part 103: Switches for rated voltages above 1 kV up to and including 52 kV

PN-EN IEC 62271-102:2018-10 *High voltage switchgear and control equipment*
 Part 102: Alternating current isolating switches and earthing switches

IEC 62271-102:2001+AMD1:2011+AMD2:2013 *High-voltage switchgear and control gear*
 Part 102: Alternating current isolating switches and earthing switches

Type - version	RN(M)(p) i RUN(M)(p)	
Rated voltage U_r	24kV	
Rated frequency f_r / number of phases	50Hz / 3	
Rated withstand voltage at power frequency U_d	To the ground and interphase	50 kV
	A safe isolation break	60 kV
Rated lightning surge withstand voltage U_p (1,2/50 μ s)	To the ground and interphase	125 kV
	A safe isolation break	145 kV
Rated continuous current I_r	400 A	
Rated short-time withstand current I_k / t_k	16 kA / 1 s	
Rated peak withstand current I_p	40 kA	
Rated breaking current in a circuit with low inductance I_{load}	100 A	
Rated breaking current in the ring network circuit I_{loop}	100 A	
Rated breaking current for charging overhead lines I_{ic}	2 A	
Rated breaking current of cable charging I_{cc}	16 A	
Rated breaking current for earth fault I_{ef1}	48 A	
Rated breaking current for charging cables and overhead lines under earth fault conditions I_{ef2}	27 A	
Electrical/mechanical durability class of the cut-off switch (5000 C-O cycles)	M2	
Rated short circuit current of the cut-off switch I_{ma}	2,5 kA	
Classification of cut-off switches for short-circuit switching	E2	
Electrical endurance class of the cut-off switches	E3	
Rated short-circuit making current of the earthing switch I_{ma}	2,5 kA	
Classification of earthing switch for short-circuit switching	E2	
Motor/manual drive (type)	NEA-__ / NRA(u) / NRMA(u)	
Operating conditions: ambient temperature	-40°C to +40°C	
Working conditions: installation height above sea level	< 1000 m	

3. Frame cut-off switches – horizontal installation on a pole

3.1. Frame cut-off switches – horizontal installation on a pole.

Outdoor cut-off switches type RN (RUN) III SA 24/4/100 have a three-pole structure with a common base (frame) and a common drive for all poles. Each pole of the disconnecter is built on two support insulators. One insulator is attached to the base (frame) and the other to the bearing-mounted movable beam. This structure ensures simultaneous closing and opening of all poles. Standard cut-off switches are made of porcelain insulators.

Additionally, they can be equipped with insulators:

- RN (RUN) III SA 24/4/100K – composite
- RN (RUN) III SA 24/4/100S – silicone

The current path of each pole consists of main contacts and an extinguishing chamber. These elements are mounted on specially profiled cassettes placed directly on the support insulators.

The main current path consists of a flat fixed contact and two profiled contacts twisted together. The moving contacts of the current path have been profiled to ensure trouble-free self-guidance and a large contact surface. Additionally, the mounting of the movable contacts has technical clearance, thanks to which the contact surface between the movable contacts and the fixed contact (or earthing switch contact) is optimal. As standard, main contacts are made of copper flat bar, protected against corrosion by tinning or silver plating. Each movable pole of the cut-off switch is standardly equipped with a movable joint with a 16-120 mm² feeder clamp. The joint is designed to prevent the cable or power cord from breaking. All connecting elements (screws, nuts) of the direct and auxiliary current circuit are made of stainless steel.

The extinguishing chamber is made of a special material resistant to electric arc and UV rays. A special mechanism is used inside and outside the chamber to disconnect and connect auxiliary contacts, which are intended to extinguish the electric arc when disconnecting a line under load.

To ensure the optimal current flow path, the connection terminals are connected to the main and auxiliary contacts via flexible copper connectors. The connection terminals allow the installation of a cable or wire with a cross-section of up to 120 mm². The cut-off switch frame is made of closed profiles and cold-formed sections. Each movable frame element is equipped with a sliding bearing made of precious metal or abrasion- and UV-resistant material. This solution guarantees failure-free operation of the switch for many years.

Corrosion protection is provided by a zinc coating made by immersion following the standard: PN-EN ISO 1461:2011/P Zinc coatings applied to steel by immersion (unit galvanizing) - Requirements and tests.

RN (RUN) III SA 24/4/100 type the cut-off switches are designed for installation in overhead power lines, on typical steel structures in a horizontal (horizontal) position.

The cut-off switches are controlled by using an NRA manual drive or a NEA motor drive. Control of the cut-off and earthing switch is only possible using the NRAu manual drive.

The drives are coupled to the switch's drive mechanism using 2 M10 screws.

Basic solutions

○ RN III SA 24/4/100 type cut-off switch

03-703
RN III SA 24/4/100



○ RUN III SA 24/4/100 type cut-off-earthing switch

03-704
RUN III SA 24/4/100



03-707
RN III SA 24/4/100K



03-708
RUN III SA 24/4/100K



03-711
RN III SA 24/4/100S



03-712
RUN III SA 24/4/100S



Basic dimensions

○ RN III SA 24/4/100 type cut-off switch

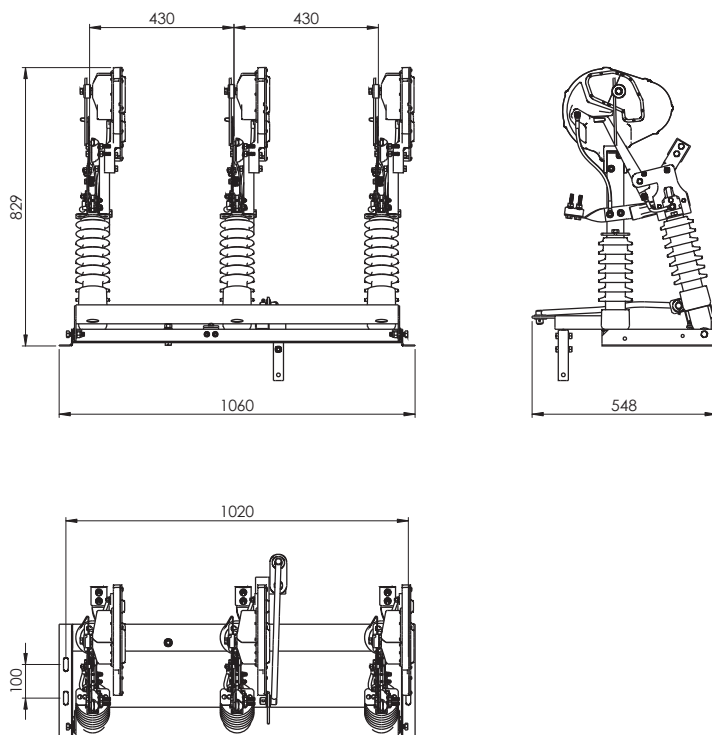

○ RUN III SA 24/4/100 type cut-off-earthing switch

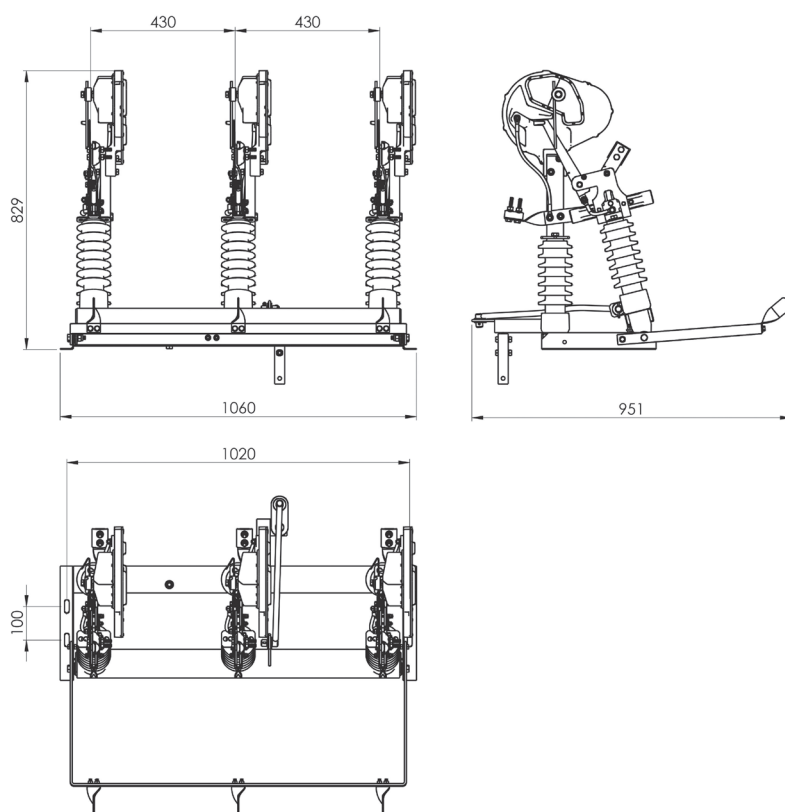

3.2. Frame cut-off switches – vertical installation on a pole.

Outdoor cut-off switches type RNp (RUNp) III SA 24/4/100 have a three-pole design with a common base (frame) and a common drive for all poles. Each pole of the disconnecter is built on two support insulators. One insulator is attached to the base (frame) and the other to the bearing-mounted movable beam. This structure ensures simultaneous closing and opening of all poles.

Standard cut-off switches are made of porcelain insulators.

Additionally, they can be equipped with insulators:

- RNp (RUNp) III SA 24/4/100K – composite
- RNp (RUNp) III SA 24/4/100S – silicone

The current path of each pole consists of main contacts and an extinguishing chamber. These elements are mounted on specially shaped cassettes placed directly on the support insulators.

The main current path consists of a flat fixed contact and two profiled contacts twisted together. The moving contacts of the current path have been profiled to ensure trouble-free self-guidance and a large contact surface. Additionally, the mounting of the movable contacts has technical clearance, thanks to which the contact surface of the movable contacts with the fixed contact (or earthing switch contact) is optimal. As standard, the main contacts are made of copper flat bar, protected against corrosion by tin-plating or silver-plating. Each movable pole of the cut-off switch is standardly equipped with a movable joint with a 16-120 mm² feeder clamp. The joint is designed to prevent the cable or power cord from breaking. All connecting elements (screws, nuts) of the direct current and auxiliary current circuit are made of stainless steel.

The extinguishing chamber is made of a special material resistant to electric arc and UV rays. A special mechanism is used inside and outside the chamber to disconnect and connect auxiliary contacts, which are intended to extinguish the electric arc when disconnecting a line under load.

To ensure the optimal current flow path, the connection terminals are connected to the main and auxiliary contacts via flexible copper connectors. The connection terminals allow for the installation of a rope or cable with a cross-section of up to 120 mm². The cut-off switch frame is made of closed profiles and cold-formed sections. Each movable frame element is equipped with a slide bearing made of precious metal or abrasion- and UV-resistant material. This solution guarantees failure-free operation of the switch for many years.

Protection against corrosion is provided by a zinc coating made by immersion following the standard: PN-EN ISO 1461:2011/P Zinc coatings applied to steel by immersion (unit galvanizing) - Requirements and tests.

RNp (RUNp) III SA 24/4/100 cut-off switches are designed for installation in overhead power lines, by using their own mounting structure in a vertical position.

The cut-off switches are controlled by a manual drive type NRA or a motor drive NEA. The cut-off and earthing switch can only be controlled by using the NRAu manual drive.

The drives are coupled to the switch's drive mechanism using 2 M10 screws.

Basic solutions

- RNp III SA 24/4/100 type cut-off switch

03-735
RNp III SA 24/4/100

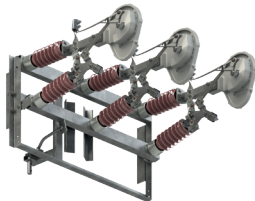

03-739
RNp III SA 24/4/100K

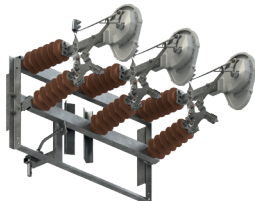

03-743
RNp III SA 24/4/100S

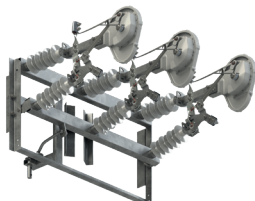

- RUNp III SA 24/4/100 type cut-off-earthing switch

03-736
RUNp III SA 24/4/100



03-740
RUNp III SA 24/4/100K

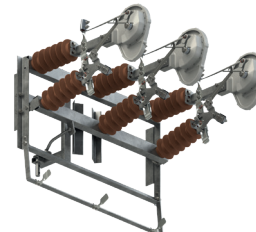

03-744
RUNp III SA 24/4/100S



Basic dimensions

○ *RNp III SA 24/4/100 type cut-off switch*

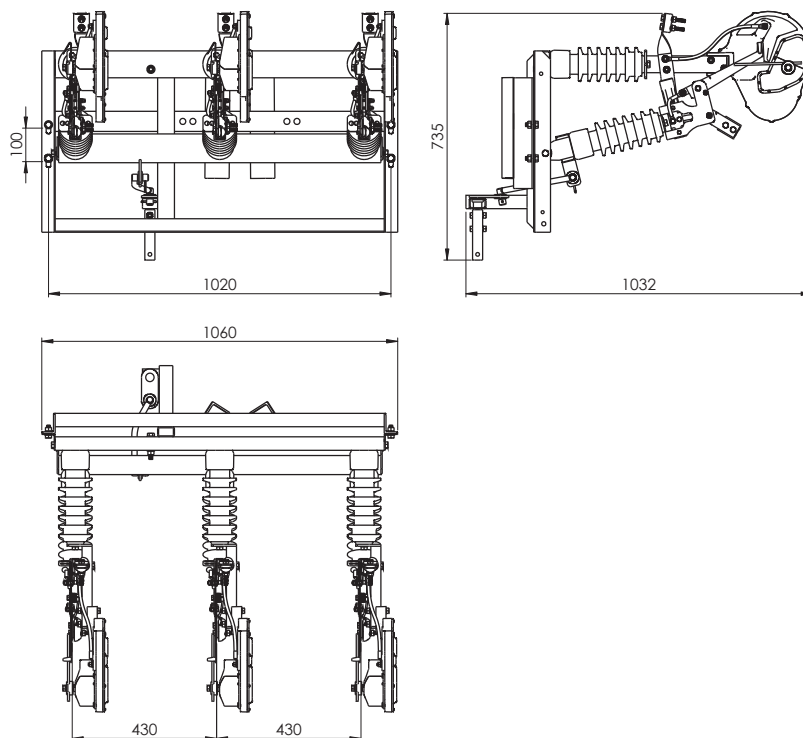

○ *RUNp III SA 24/4/100 type cut-off-earthing switch*

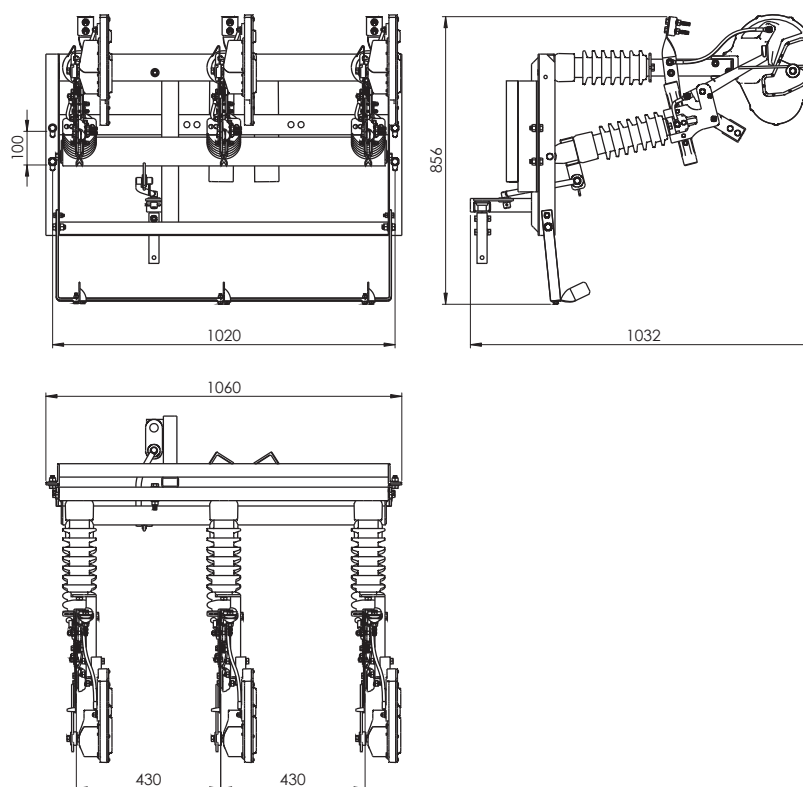

3.3. Modular cut-off switches – horizontal installation on a pole.

RNM (RUNM) III SA 24/4/100 type overhead cut-off switches have a three-pole structure with a common beam and a common drive for all poles. Each pole of the cut-off switch is built on two support insulators. One insulator is attached to the fixed base and the other to the bearing-mounted movable cassette. This structure ensures simultaneous closing and opening of all poles. The modular structure of the RNM (RUNM) III SA 24/4/100 cut-off switch allows you to independently set the poles to each other while maintaining minimum, safe distances. These switches can be installed at the top (above the pole conductors) and on the pole leg in a horizontal position.

When ordering a modular cut-off switch (cut-off-earthing switch) intended for installation on the top of a pole, please provide the type of structure to which the switch is to be attached (see **Booklet 4: Fastening switches in overhead MV lines**). When ordering a modular switch (cut-off-earthing switch) intended for installation on a pole leg, please provide the top diameter of the spun pole.

Modular cut-off switches are usually built on porcelain insulators. Additionally, they can be equipped with insulators:

- RNM (RUNM) III SA 24/4/100K – composite
- RNM (RUNM) III SA 24/4/100S – silicone

The current path of each pole consists of main contacts and an extinguishing chamber. These elements are mounted on specially shaped cassettes placed directly on the support insulators.

The main current path consists of a flat fixed contact and two profiled contacts twisted together. The moving contacts of the current path have been profiled to ensure trouble-free self-guidance and a large contact surface. Additionally, the mounting of the movable contacts has technical clearance, thanks to which the contact surface of the movable contacts with the fixed contact (or earthing switch contact) is optimal.

As standard, the main contacts are made of copper flat bar, protected against corrosion by tinning or silver plating. Each movable pole of the cut-off switch is equipped with a movable joint with a 16-120 mm² current terminal as standard. The joint is designed to prevent the cable or power cord from breaking. All connecting elements (screws, nuts) of the direct and auxiliary current circuit are made of stainless steel.

The extinguishing chamber is made of a special material resistant to electric arc and UV rays. A special mechanism is used inside and outside the chamber to enable the cut-off switch and activation of auxiliary contacts, which are intended to extinguish the electric arc when disconnecting a line under load.

To ensure the optimal current flow path, the connection terminals are connected to the main and auxiliary contacts via flexible copper connectors. The connection terminals allow for the installation of a rope or cable with a cross-section of up to 120 mm². The main beam and the supporting elements of the switches are made of closed profiles and cold-bent sections. Each movable beam element is equipped with a slide bearing made of noble metal or abrasion- and UV-resistant material. This solution guarantees failure-free operation of the switch for many years.

Corrosion protection is provided by a zinc coating made by immersion following the standard: PN-EN ISO 1461:2011/P.

The cut-off switch is controlled by using an NRA manual drive or an NEA motor drive. The cut-off and earthing switch can only be controlled using the NRAu manual drive.

The modular cut-off switch can be controlled by a reciprocating drive, type NRMA(u). Details of connection and operation are shown in section 4 NRMA, NRMAu hand drives.

Basic solutions

○ RNM III SA 24/4/100 type cut-off switch

03-751
RNM III SA 24/4/100



03-755
RNM III SA 24/4/100K



03-759
RNM III SA 24/4/100S



○ RUNM III SA 24/4/100 type cut-off-earthing switch

03-752
RUNM III SA 24/4/100



03-756
RUNM III SA 24/4/100K



03-760
RUNM III SA 24/4/100S



Basic dimensions

- RNM III SA 24/4/100 type cut-off switch

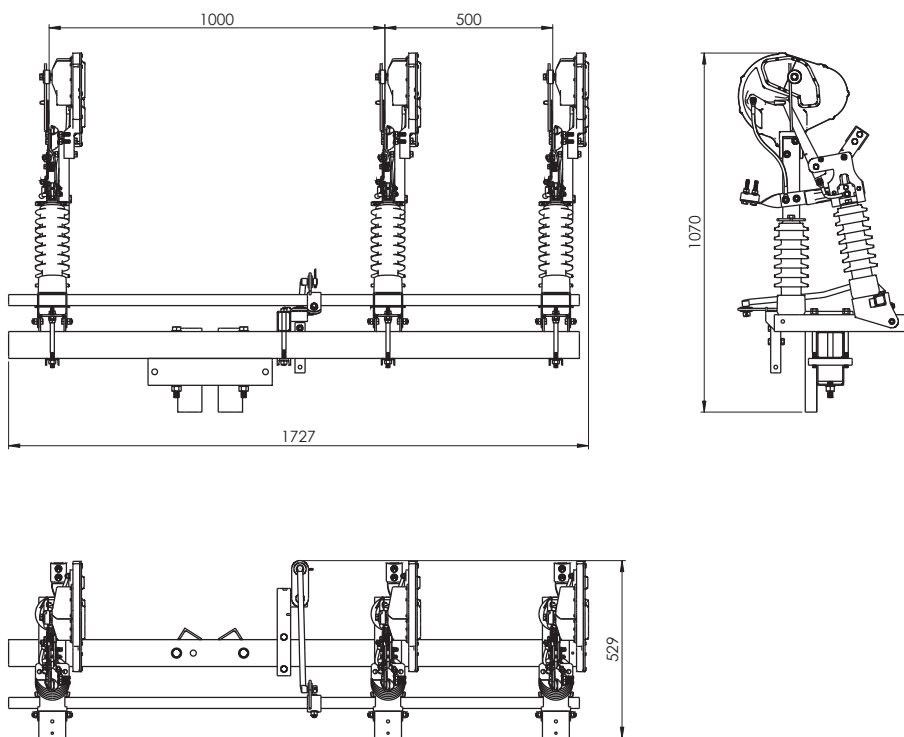

- RUNM III SA 24/4/100 type cut-off-earthing switch

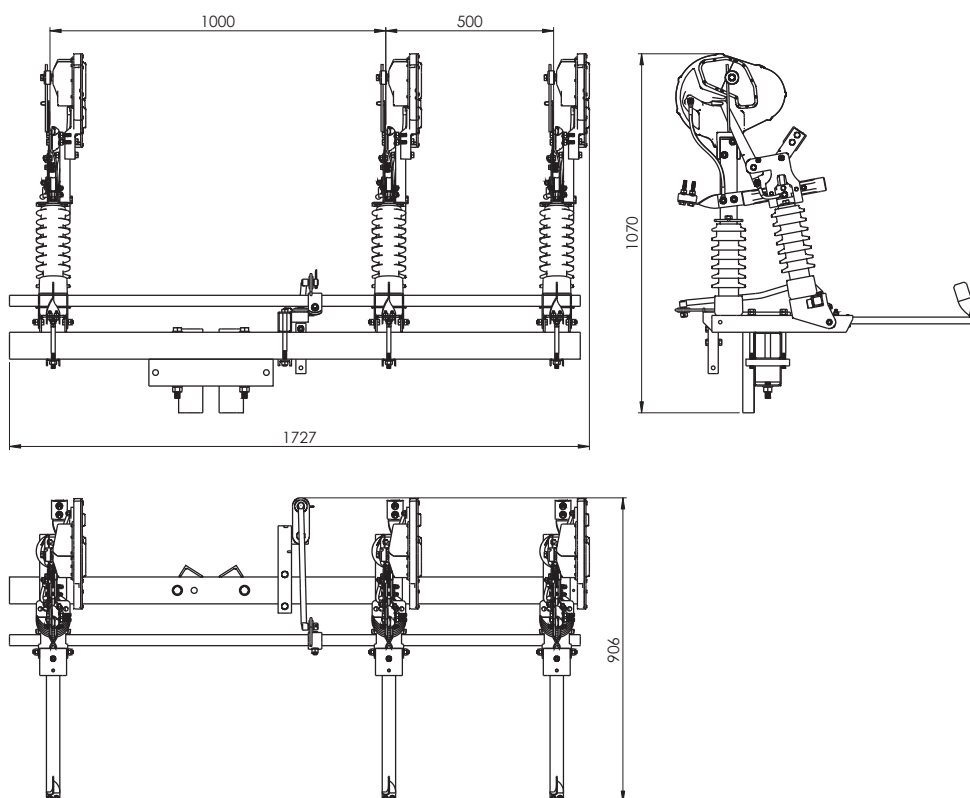

3.4. Modular cut-off switch – vertical installation on a pole.

Outdoor cut-off switches type RNMP (RUNMP) III SA 24/4/100 have a three-pole structure with a common beam and a common drive for all poles. Each pole of the cut-off switch is built on two support insulators. One insulator is attached to the fixed base and the other to the movable cassette with bearings. This structure ensures simultaneous closing and opening of all poles. The modular structure of RNMP (RUNMP) III SA 24/4/100 cut-off switches allows you to independently set the poles to each other while maintaining minimum, safe distances. These switches can only be installed on the pole leg (above the pole conductors) in a vertical position. When ordering, please provide the top diameter of the spun column.

Modular cut-off switches are usually built on porcelain insulators. Additionally, they can be equipped with insulators:

- RNMP (RUNMP) III SA 24/4/100K – composite
- RNMP (RUNMP) III SA 24/4/100S – silicone

The current path of each pole consists of main contacts and an extinguishing chamber. These elements are mounted on specially shaped cassettes placed directly on the support insulators.

The main current path consists of a flat fixed contact and two profiled contacts twisted together.

The moving contacts of the current path have been profiled to ensure trouble-free self-guidance and a large contact surface. Additionally, the mounting of the movable contacts has technical clearance, thanks to which the contact surface of the movable contacts with the fixed contact (or earthing switch contact) is optimal.

As standard, the main contacts are made of copper flat bar, protected against corrosion by tin-plating or silver-plating. Each movable pole of the disconnecter is standardly equipped with a movable joint with a 16-120 mm² current terminal. The joint is designed

to prevent the cable or power cord from breaking. All connecting elements (screws, nuts) of the direct and auxiliary current circuit are made of stainless steel.

The extinguishing chamber is made of a special material resistant to electric arc and UV rays. A special mechanism is used inside and outside the chamber to disconnect and connect auxiliary contacts, which are intended to extinguish the electric arc when disconnecting a line under load.

To ensure the optimal current flow path, the connection terminals are connected to the main and auxiliary contacts via flexible copper connectors. The connection terminals allow the installation of a cable or wire with a cross-section of up to 120 mm². The main beam and the supporting elements of the switches are made of closed profiles and cold-bent sections. Each moving element of the beam is equipped with a slide bearing made of noble metal or abrasion- and UV-resistant material. This solution guarantees failure-free operation of the switch for many years. Protection against corrosion is provided by a zinc coating made by immersion following the standard: PN-EN ISO 1461:2011/P Zinc coatings applied to steel by immersion (unit galvanizing) - Requirements and tests.

The disconnecter is controlled by a manual drive type NRA or a motor drive NEA. The switch disconnecter control of the earthing switch is only possible using the NRAu manual drive.

The drives are coupled to the switch's drive mechanism using 2 M10 screws.

Modular switch disconnectors can be controlled by a reciprocating drive, type NRMA(u). Details of connection and operation are shown in section 4 NRMA, NRMAu hand drives.

Basic solutions

- RNMP III SA 24/4/100 type cut-off switch

03-719
RNMP III SA 24/4/100



- RUNMP III SA 24/4/100 type cut-off-earthing switch

03-720
RUNMP III SA 24/4/100



03-723
RNMP III SA 24/4/100K

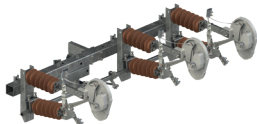

03-724
RUNMP III SA 24/4/100K

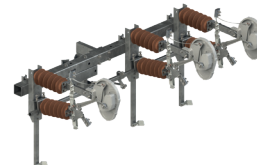

03-727
RNMP III SA 24/4/100S



03-728
RUNMP III SA 24/4/100S

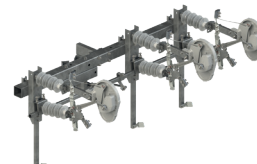

Basic dimensions

- RNMp III SA 24/4/100 type cut-off switch

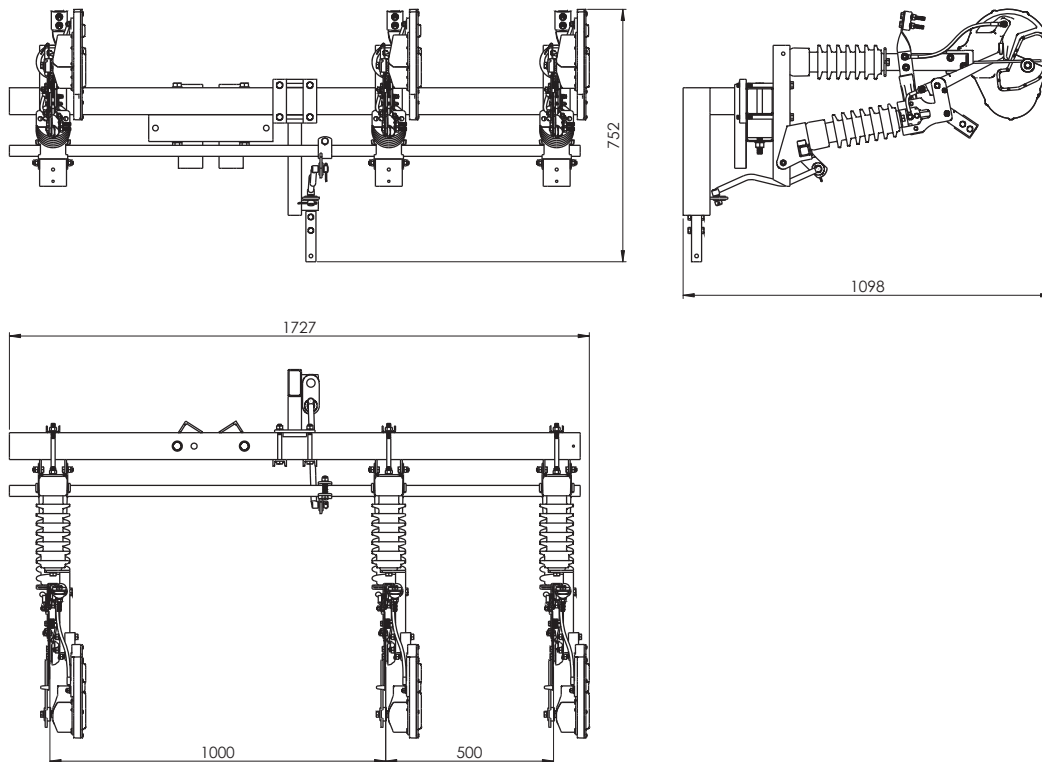

- RUNMp III SA 24/4/100 type cut-off-earthing switch

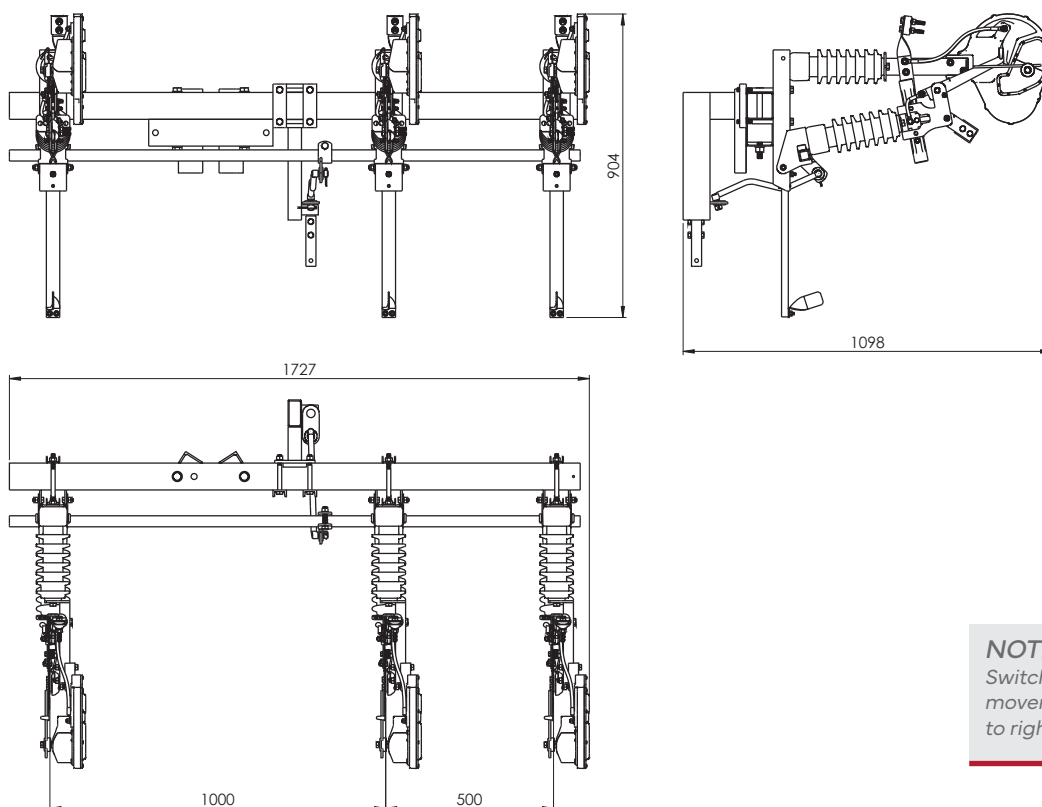

NOTE!
Switches with left-hand movement. Opening from left to right.

4. Using the cut-off switches

NOTE!

It is unacceptable to grab the elements of the current circuit, the extinguishing chamber and the support insulators of the cut off switches.

The cut-off switches are delivered to the customer completely assembled and adjusted - always in the closed position. After unpacking, check whether the device has not suffered mechanical damage during transport and whether the data on the rating plate are consistent. Particular attention should be paid to the extinguishing chamber and its auxiliary contacts - this mechanism should be intact (any type of repairs are not allowed without the involvement of the manufacturer's service) and not mechanically damaged during transport, unloading or assembly. When mounting the cut-off switch on a pole and coupling it with NRA(u), NRMA(u) or NEA motorized drives, the device should be in the closed position. When installing the manual drive, the drive key should be on the right side in the closed position.

NOTE!

This does not apply to modular cut off switches operating in a vertical position (vertical). These cut off switches operate in a left-hand direction and the operating key should be on the left side (not applicable to NRMA(u) manual drives).

NOTE!

Installing a drive other than an NRA(u), NRMA(u) or NEA drive is not permitted.

The switches are designed to connect conductors with a cross-section of up to 120 mm². Before connecting, it is recommended to clean the contact surfaces of the connecting elements (connection terminals) from any contamination and lubricate them with a layer of conductive grease (acid-free). To reduce friction resistance, all moving steel elements (bearings, joints, moving parts of the drive key) should be lubricated with grease (e.g. ŁT-43).

Before putting the switch into operation, check the condition of the device, correct coupling with the drive and correct operation. The switch should be visually inspected, checking the condition of the insulators (dirt, cracks, etc.) and the correct tightening of the screw connections - in particular the cable connections, the connection to the drive and the attachment of the apparatus to the supporting structure. Then, perform several switching cycles, paying attention to the correct operation of the main contacts (recharging when closing) and auxiliary contacts of the chamber.

5. Inspections and maintenance

5.1. Inspections

- It is recommended that cut-off switches be inspected once every five years to ensure trouble-free operation and:
- Each time the main contacts are replaced
- After switching on the disconnecter, there is a short circuit

During inspections, particular attention should be paid to:

- Condition of insulators (scratches, cracks, etc.)
- Condition of main contacts (dirt, traces of melting)
- Condition of the extinguishing chamber (connection to the support holder, clean the chamber outlet)
- Condition of the screw connections of the connector (cable connections, connections to the drive, attachment of the device to the supporting structure)
- Condition of the switch driving mechanism
- Condition of protective coatings

5.2. Maintenance

- It is recommended to perform maintenance of the cut-off switch after each inspection. Maintenance scope includes:
- Cleaning the insulators
- Cleaning the extinguishing chamber
- Cleaning the main contacts
- Lubricating of main contacts with conductive grease (acid-free)
- Tightening any loose screw connections
- Replacing damaged protective coatings (cold zinc spray)

CHAPTER 4

Manual drives of switches

NRA
NRA_U

Manual drives of switches

NRMA
NRMA_U

Motor drives of switches

NEA

NRA, NRAu manual drives

1. Characteristics and intended use

NRA and NRAu type drives are intended for manual control of the operation of overhead switches (NRA) and switches with earthing switches (NRAu) produced by Alpar Ltd.

NRA
NRAu

The structure of the key is made as a pass-through structure for the drive cable - this allows you to adjust the mounting height of the key to the pole, which in turn allows you to install it at the most convenient height.

NRA(u) keys enable the installation of both square and round drive cables.

2. How to order manual drives

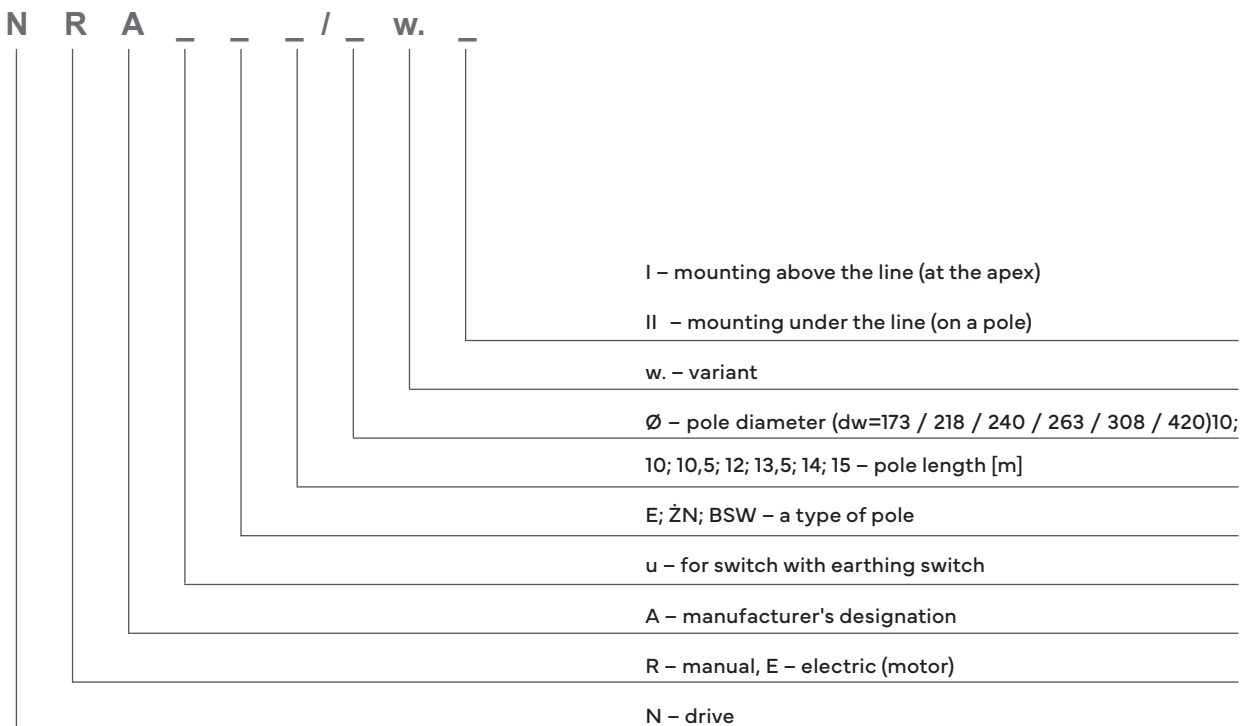

Marking examples:

NRAu E12/263 w.II

– Manual drive for a switch with an earthing switch, mounted under the line, on an E-type pole with a top diameter of fi263 and a length of 12 meters

NRA E13,5 w. I

– Manual drive for the connector, mounted above the line, on an E-type pole with a length of 13.5 meters

3. List of manual drive components

Drive kit type	Tie		Articulated tie		Guide	Drive key mounting										Drive key			
	I=3000	I=1500	I=2000	I=1000		E										BSW	NRA	NRAu	
						EP-2/1	dw=173	dw=218	dw=218	dw=263	dw=218	dw=263	dw=263	dw=218	dw=263				dw=308
NRA E-10,5 w.I	2		1		2	1	1+M16x70	1+M16x140	1+M16x120	1+M16x180	1+M16x220	1+M16x180	1+M16x120	1+M16x70				1	
NRA E-10,5 w.II	1	1	1		2	1	1+M16x70	1+M16x140	1+M16x120	1+M16x180	1+M16x220	1+M16x180	1+M16x120	1+M16x70				1	
NRAu E-10,5 w.I	2		1		2	1	1+M16x70	1+M16x140	1+M16x120	1+M16x180	1+M16x220	1+M16x180	1+M16x120	1+M16x70					1
NRAu E-10,5 w.II	1	1	1		2	1	1+M16x70	1+M16x140	1+M16x120	1+M16x180	1+M16x220	1+M16x180	1+M16x120	1+M16x70					1
NRA E-12 w.I	2		1		3	1	1+M16x120	1+M16x220	1+M16x180	1+M16x120	1+M16x70	1+M16x180	1+M16x120	1+M16x70				1	
NRA E-12 w.II	2		1		3	1	1+M16x120	1+M16x220	1+M16x180	1+M16x120	1+M16x70	1+M16x180	1+M16x120	1+M16x70				1	
NRAu E-12 w.I	2	1	1		3	1	1+M16x120	1+M16x220	1+M16x180	1+M16x120	1+M16x70	1+M16x180	1+M16x120	1+M16x70				1	
NRAu E-12 w.II	2	1	1		3	1	1+M16x120	1+M16x220	1+M16x180	1+M16x120	1+M16x70	1+M16x180	1+M16x120	1+M16x70				1	
NRA E-13,5 w.I	3		1		3	1	1+M16x120	1+M16x220	1+M16x180	1+M16x120	1+M16x70	1+M16x180	1+M16x120	1+M16x70				1	
NRA E-13,5 w.II	2	1	1		3	1	1+M16x120	1+M16x220	1+M16x180	1+M16x120	1+M16x70	1+M16x180	1+M16x120	1+M16x70				1	
NRAu E-13,5 w.I	3		1		3	1	1+M16x120	1+M16x220	1+M16x180	1+M16x120	1+M16x70	1+M16x180	1+M16x120	1+M16x70				1	
NRAu E-13,5 w.II	2	1	1		3	1	1+M16x120	1+M16x220	1+M16x180	1+M16x120	1+M16x70	1+M16x180	1+M16x120	1+M16x70				1	
NRA E-15 w.I	3	1	1		4	1	1+M16x180		1+M16x180	1+M16x180	1+M16x180	1+M16x180	1+M16x70				1		
NRA E-15 w.II	3	1	1		3	1	1+M16x180		1+M16x180	1+M16x180	1+M16x180	1+M16x180	1+M16x70				1		
NRAu E-15 w.I	3	1	1		4	1	1+M16x180		1+M16x180	1+M16x180	1+M16x180	1+M16x180	1+M16x70				1		
NRAu E-15 w.II	3	1	1		4	1	1+M16x180		1+M16x180	1+M16x180	1+M16x180	1+M16x180	1+M16x70				1		
NRA E-16,5 w.I	4		1		4	1	1+M16x220		1+M16x220	1+M16x220	1+M16x220	1+M16x220	1+M16x120				1		
NRA E-16,5 w.II	3	1	1		4	1	1+M16x220		1+M16x220	1+M16x220	1+M16x220	1+M16x220	1+M16x120				1		
NRAu E-16,5 w.I	4		1		4	1	1+M16x220		1+M16x220	1+M16x220	1+M16x220	1+M16x220	1+M16x120				1		
NRAu E-16,5 w.II	3	1	1		4	1	1+M16x220		1+M16x220	1+M16x220	1+M16x220	1+M16x220	1+M16x120				1		
NRA E-18 w.I	4	1	1		5	1	1+M16x220		1+M16x220	1+M16x220	1+M16x220	1+M16x220	1+M16x180	1+M16x70	1+M16x180	1+M16x180	1		
NRA E-18 w.II	4	1	1		4	1	1+M16x220		1+M16x220	1+M16x220	1+M16x220	1+M16x220	1+M16x180	1+M16x70	1+M16x180	1+M16x180	1		
NRAu E-18 w.I	4	1	1		5	1	1+M16x220		1+M16x220	1+M16x220	1+M16x220	1+M16x220	1+M16x180	1+M16x70	1+M16x180	1+M16x180	1		
NRAu E-18 w.II	4	1	1		4	1	1+M16x220		1+M16x220	1+M16x220	1+M16x220	1+M16x220	1+M16x180	1+M16x70	1+M16x180	1+M16x180	1		
NRA ŻN-12 w.I	2	1	1			3											2	1	1
NRA ŻN-12 w.II	2	1	1			3											2	1	1
NRAu ŻN-12 w.I	2	1	1			3											2	1	1
NRAu ŻN-12 w.II	2	1	1			3											2	1	1
NRA BSW-12 w.I	2	1	1 (3-way sys.)	1 (flat sys.)		3											2	1	1
NRA BSW-12 w.II	2	1	1 (3-way sys.)	1 (flat sys.)		3											2	1	1
NRAu BSW-12 w.I	2	1	1 (3-way sys.)	1 (flat sys.)		3											2	1	1
NRAu BSW-12 w.II	2	1	1			3											2	1	1
NRA BSW-14 w.I	3	1		1		3											2	1	1
NRA BSW-14 w.II	3	1		1		3											2	1	1
NRAu BSW-14 w.I	3	1		1		3											2	1	1
NRAu BSW-14 w.II	3	1		1		3											2	1	1

We use one OP-2/1 set depending on the top diameter of the rod on which the drive set will be installed.

4. Construction

Manual drives for overhead switches of the NRA and NRA(u) types are made of steel, and protected against corrosion by hot-dip galvanizing following the PN-EN ISO 1461:2011P standard. These are drives with rotary motion.

Manual drives consist of:

- Drive key | Intermediate element with clamp | Pole guides with clamps | Drive cable | Tie rod joint | Insulation bar (optional)

5. List of drive components

○ For spun rods E

○ For concrete poles ŽN, BSW

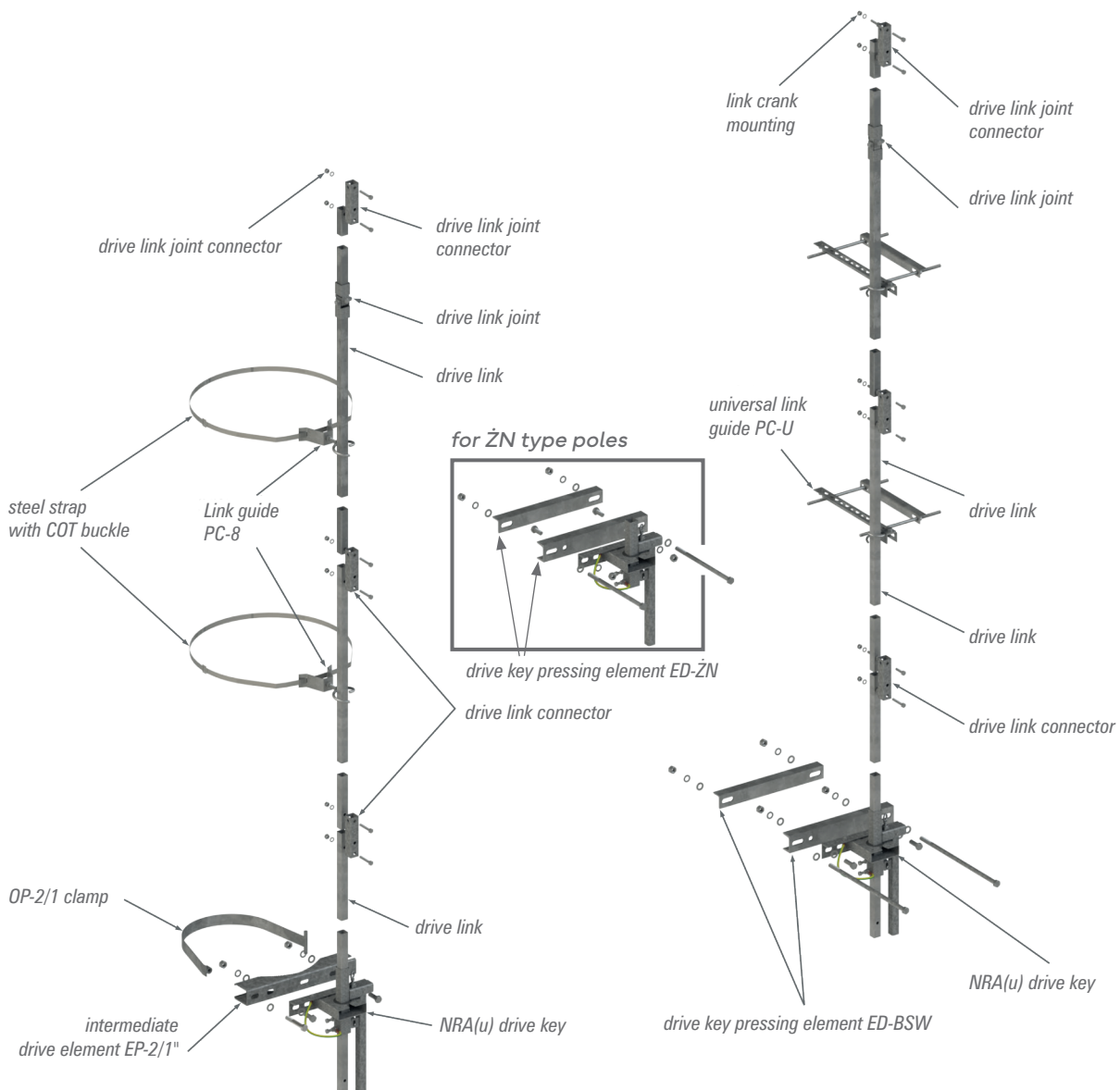

6. Description of drive operation

When mounting to a pole, each manual drive should be coupled to the connector in the closed position.

6.1. NRA-type drives allow for two-stage switch operation

○ Switch closed

- 0° key on the right
- switch in closed position*

○ Open connector

- 180° key on the left side
- switch in open position

DRIVE KEY VIEW

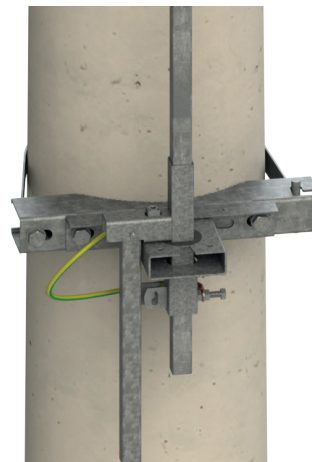
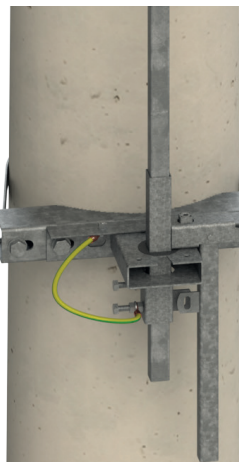

VIEW FROM THE TOP

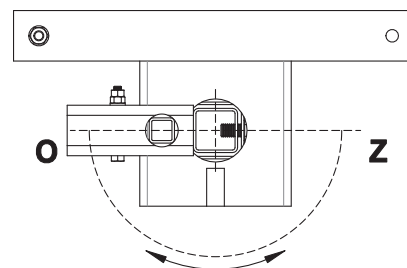
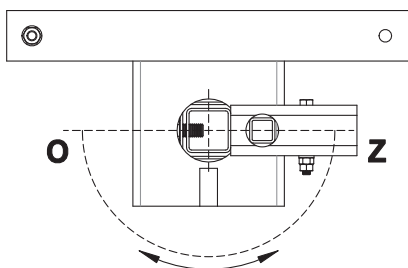

In each operating position, the NRA drive key can be additionally secured against opening with an energy padlock.

NOTE!

This type of drive should only be used for switches without an earthing switch.



Does not apply to vertical modular connectors (vertical).
For this group of switches, the drive key handle must be on the left side.

6.2. NRAu drives allow for three-stage switch operation

○ Switch closed

- 0° key on the right
- switch in closed position*

○ Open, ungrounded switch

- 90° key in the middle position
- switch in open position, not grounded

○ Open, grounded switch

- 180° key on the left side
- switch in open position, grounded

DRIVE KEY VIEW

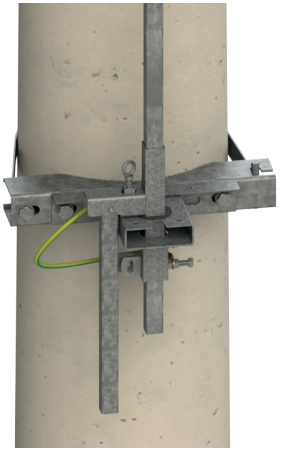
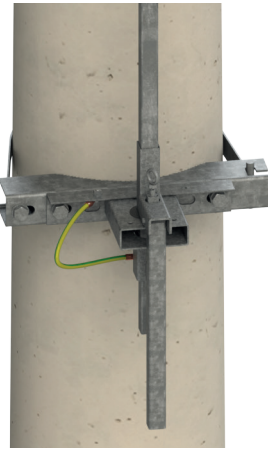
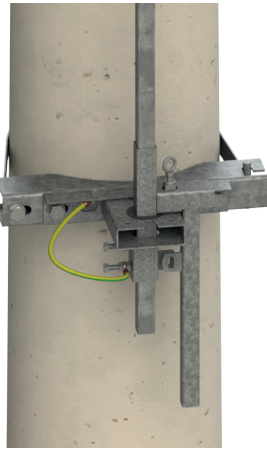

VIEW FROM THE TOP

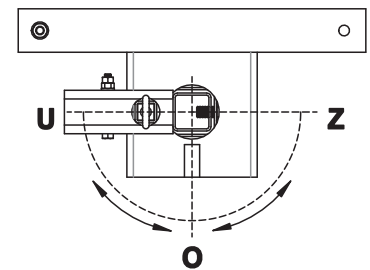
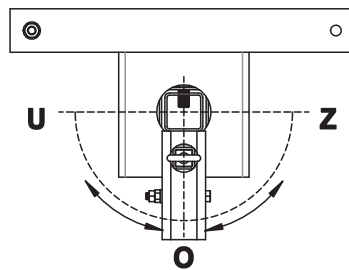
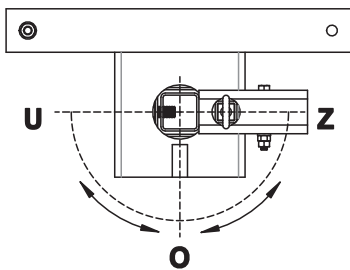

Thanks to the use of a special lock in the manual drive key (applies only to the NRA(u) type) - when opening, the lock automatically stops the switch in the open, unearthed position. This solution guarantees that the connector will always open in an intermediate position. To move the switch to the third position, i.e.: open, grounded; release the handwheel lock by lifting the trigger.

In each operating position, the NRAu drive key can be additionally secured against manoeuvring by using an energy padlock.



*Does not apply to vertical modular connectors (vertical).
For this group of switches, the drive key handle must be on the left side.*

NRMA, NRMAu manual drives

1. Characteristics and intended use

NRMA and NRMAu drives are intended for manual control of the operation of overhead switches (NRMA) and switches with earthing switches (NRMAu) manufactured by Alpar Ltd.

The structure of the key is made as a pass-through structure for the drive cable - this allows the adjustment of the height of mounting the key to the pole, which in turn allows it to be mounted at the most convenient height.

NRMA(u) keys enable the installation of both square and round drive cables.

NRMA
NRMAu

2. How to order manual drives

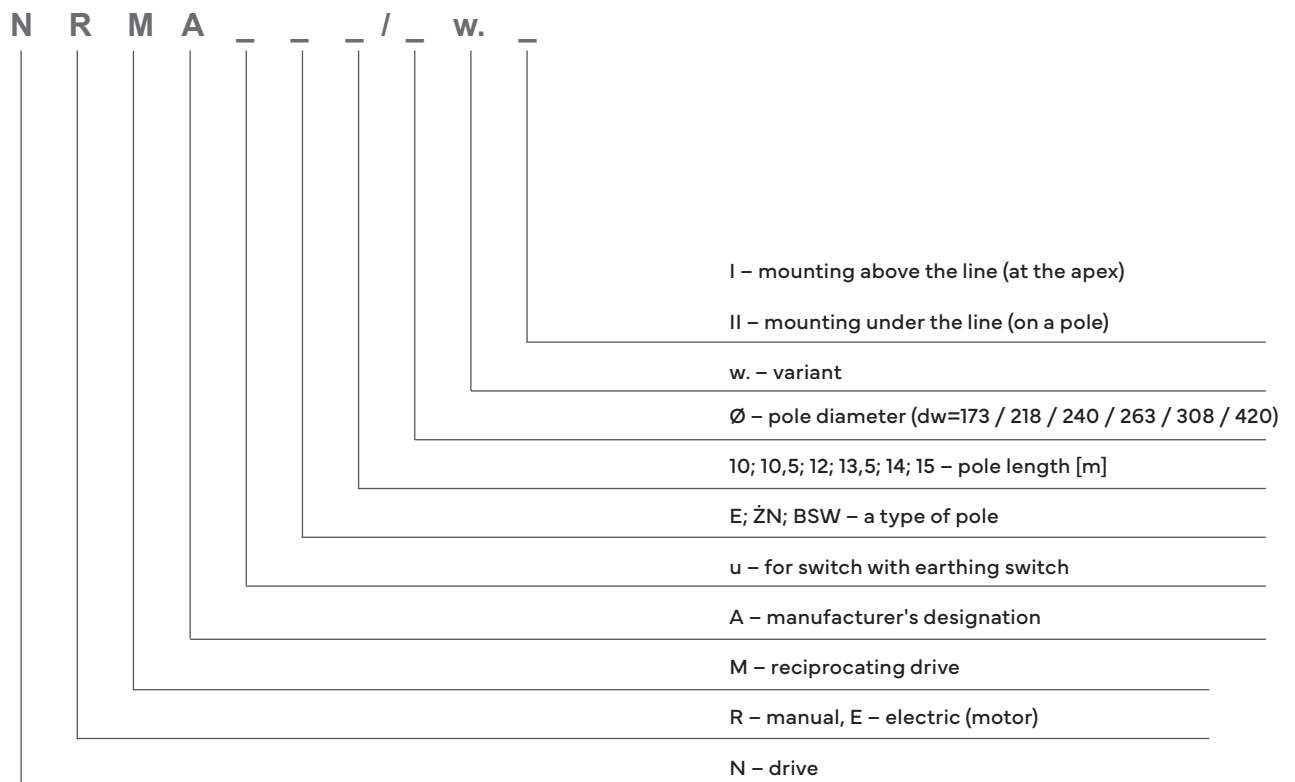

Marking examples:

NRMAu E12/263 w.II

– Manual drive for a switch with an earthing switch, mounted under the line, on an E-type pole with a top diameter of fi263 and a length of 12 meters

NRMA E13,5 w.I

– Manual drive for the connector, mounted above the line, on an E-type pole with a length of 13.5 meters

3. List of manual drive components

Drive type	Tie rods		L-2500 tie rod + fastening of the switch crank	Guides			Key attachment			Key
	ECN-1S L-3000	ECN-3S L-1500		E	ŽN	BSW	E	ŽN	BSW	
				PC-GD	PC-GD	PC-GD	EP-1/E			
NRMA E-12 w.I	2	1	1	2			OB-11 OB-12			NRMA
NRMA E-12 w.II	2		1	2			OB-11 OB-12			NRMA
NRMAu E-12 w.I	2	1	1	2			OB-11 OB-12			NRMAu
NRMAu E-12 w.II	2		1	2			OB-11 OB-12			NRMAu
NRMA E-13,5 w.I	3		1	2			OB-11 OB-12			NRMA
NRMA E-13,5 w.II	2	1	1	2			OB-11 OB-12			NRMA
NRMAu E-13,5 w.I	3		1	2			OB-11 OB-12			NRMAu
NRMAu E-13,5 w.II	2	1	1	2			OB-11 OB-12			NRMAu
NRMA E-15 w.I	3	1	1	2			OB-11 OB-12+			NRMA
NRMA E-15 w.II	3		1	2			OB-11 OB-12+			NRMA
NRMAu E-15 w.I	3	1	1	2			OB-11 OB-12+			NRMAu
NRMAu E-15 w.II	3		1	2			OB-11 OB-12+			NRMAu
NRMA ŽN-12 w.I	2	1	1		2			1		NRMA
NRMA ŽN-12 w.II	2		1		2			1		NRMA
NRMAu ŽN-12 w.I	2	1	1		2			1		NRMAu
NRMAu ŽN-12 w.II	2		1		2			1		NRMAu
NRMA BSW-12 w.I	2	1	1			2			1	NRMA
NRMA BSW-12 w.II	2		1			2			1	NRMA
NRMAu BSW-12 w.I	2	1	1			2			1	NRMAu
NRMAu BSW-12 w.II	2		1			2			1	NRMAu
NRMA BSW-14 w.I	3	1	1			2			1	NRMA
NRMA BSW-14 w.II	3		1			2			1	NRMA
NRMAu BSW-14 w.I	3	1	1			2			1	NRMAu
NRMAu BSW-14 w.II	3		1			2			1	NRMAu

4. Construction

Manual drives for overhead switches of the NRMA and NRMAu types are made of steel, and protected against corrosion by hot-dip galvanizing following the PN-EN ISO 1461:2011P standard. These are drives with reciprocating motion.

Manual drives consist of:

Drive key | Intermediate element with clamp | Pole guides with clamps. | Drive cable | Tie joint. | Insulation bar (optional)

5. List of drive components

○ For E-spun poles

○ For ŻN/BSW concrete poles

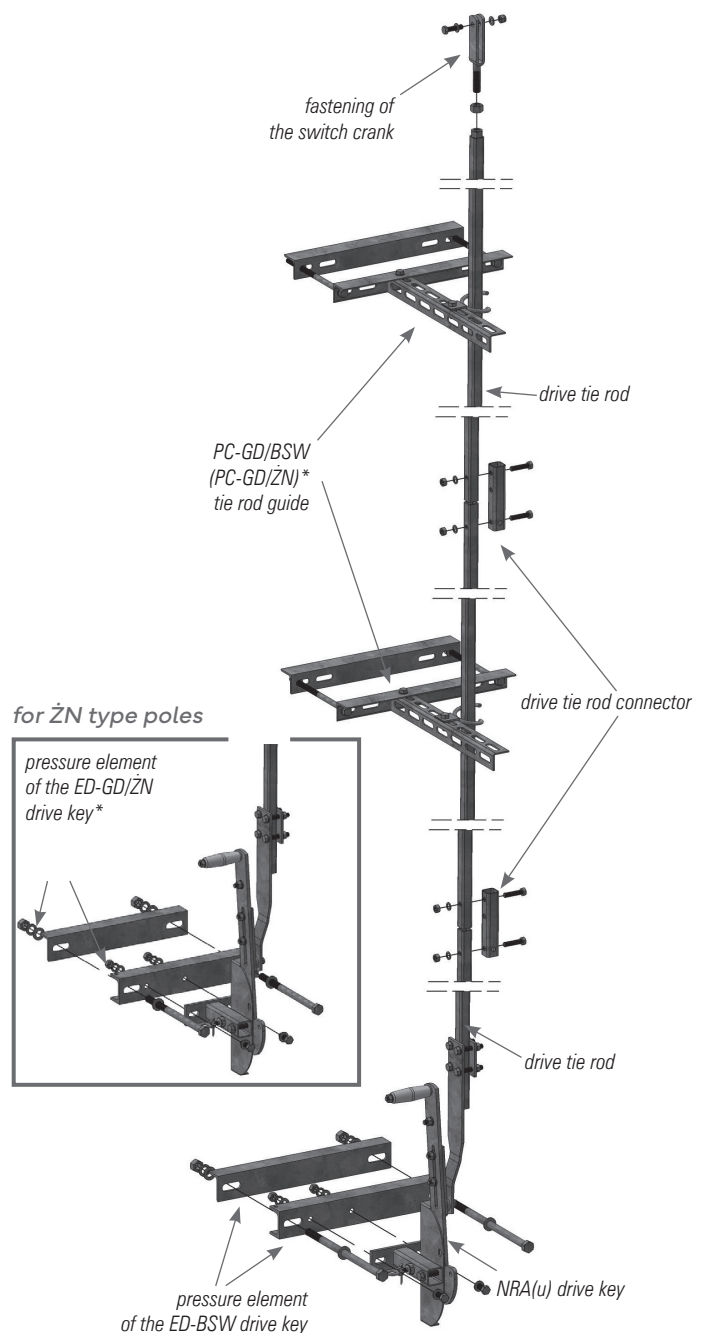
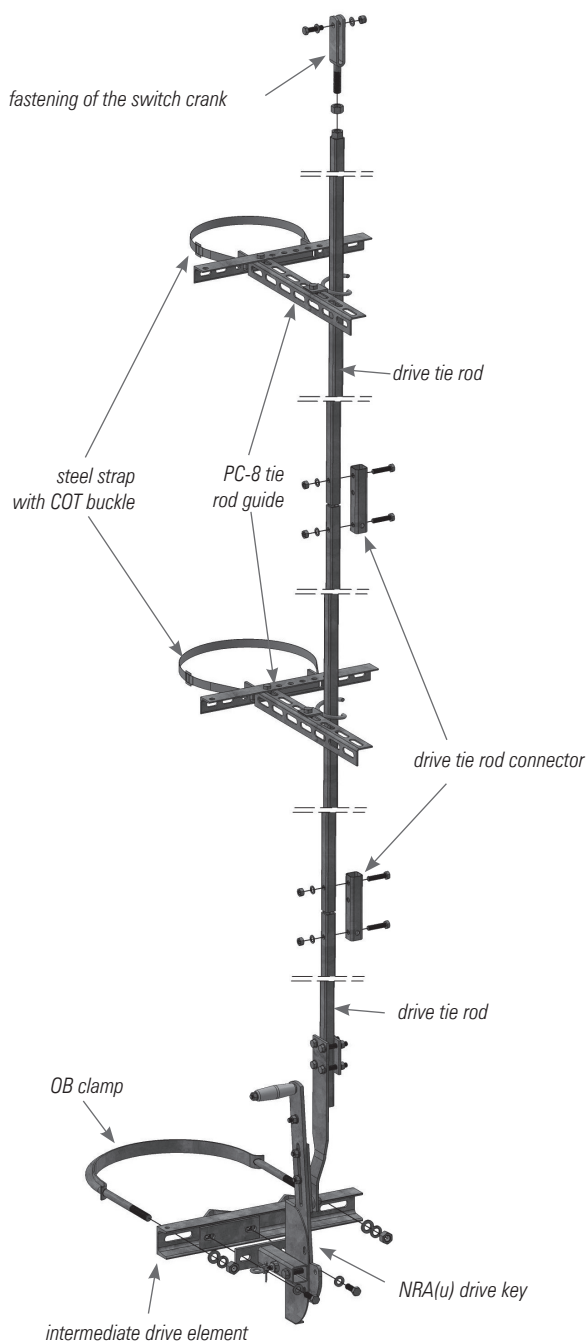

6. Description of drive operation

When mounting to a pole, each manual drive should be coupled to the connector in the closed position.

6.1. NRMA type drives allow for two-stage operation of the switch

○ Switch closed

- 0° key in the up position
- switch in closed position*

○ Switch opened

- 180° key in the down position
- switch in open position

DRIVE KEY VIEW

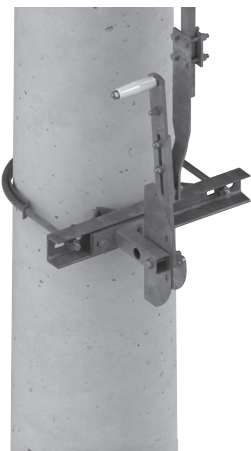

SIDE VIEW

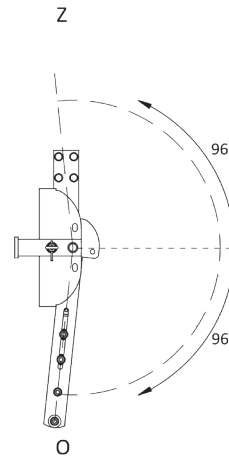
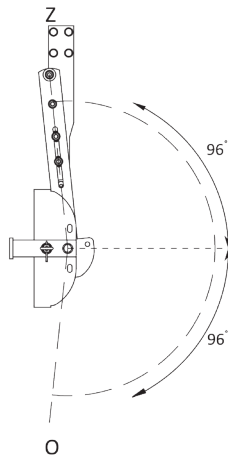

*In any operating position, the NRMA drive key can be additionally secured against opening with an energy padlock

NOTE!

This type of drive should only be used for switches without an earthing switch.



Does not apply to vertical modular connectors (vertical).
For this group of switches, the drive key handle must be on the left side.

6.2. NRMAu type drives allow for three-stage operation of the switch

○ Switch closed

0° key in the up position
– switch in closed position*

○ Open, ungrounded switch

90° key in the middle position
– switch in open position, not grounded

○ Open, grounded switch

180° key in the down position
– switch in open position, grounded

DRIVE KEY VIEW

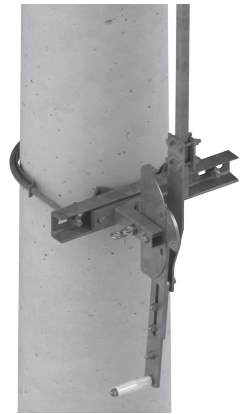
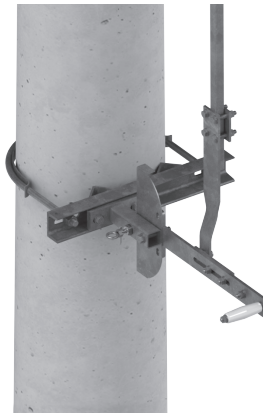
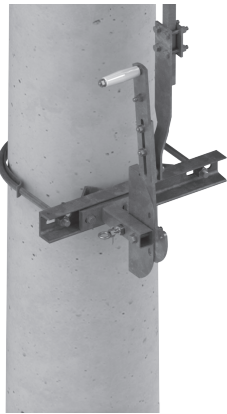

SIDE VIEW

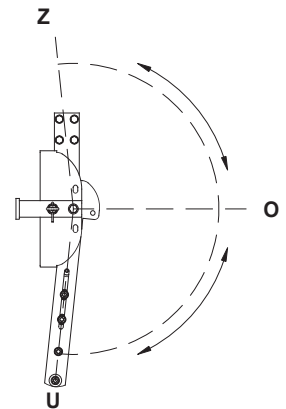
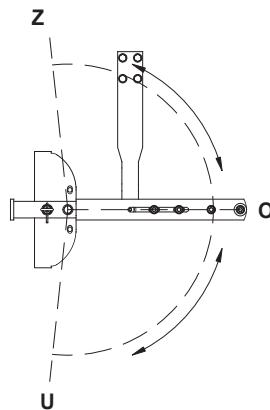
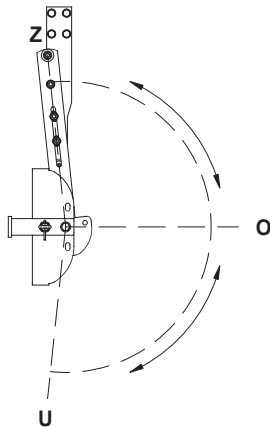

VIEW OF THE POSITION OF THE MOVABLE BEAM (POLES)

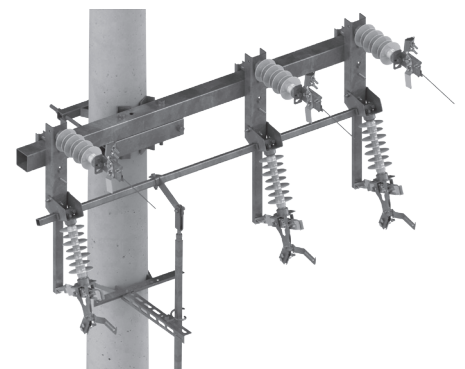
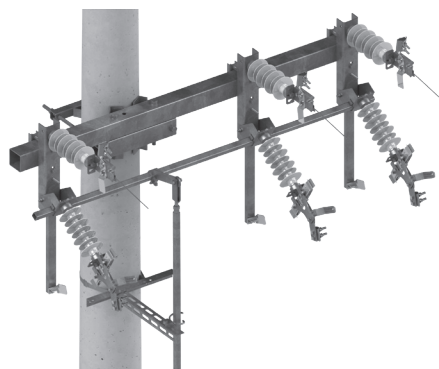
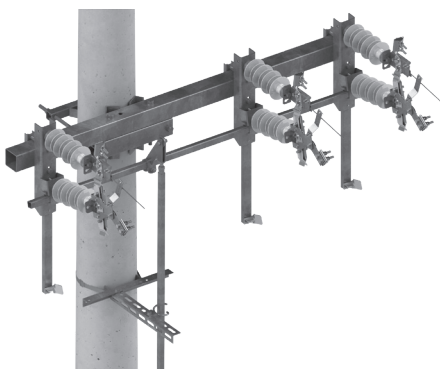

Thanks to the use of a special lock in the manual drive key (applies only to the NRMAu type) - during opening, the lock automatically stops the switch in the open, ungrounded position. This solution guarantees that the connector will always open in an intermediate

position. To move the switch to the third position, e.: open, grounded; release the handwheel lock by lifting the trigger.

In each operating position, the NRAu drive key can be additionally secured against manoeuvring by using an energy padlock.

NEA motor drives

1. Characteristics and intended use

The NEA-02 drive is designed to work with all commercially available medium-voltage overhead line devices by using the rotary movement of the rod.

The closer gear and control system are placed inside a sealed cover with an IP54 protection class.

The cover is made of a powder-coated aluminium sheet. There is a thermal insulation layer on the inside.

The cover can be equipped with any type of lock, according to the customer's wishes. A properly selected mechanical system cooperates with a high-class electronic system. The electronic system performs the function of turning on and off the engine with the PWM soft start function limiting the starting current and enabling cooperation with any telemechanics system. The drive uses a high-efficiency, 250 W motor with permanent magnets - which allows you to achieve very high torques and very short opening/closing times of the switches - at the level of 1.5 s. The front panel contains the necessary elements to control the drive (on/off buttons, operation selection switch, crank) and a mechanical-electric locking system with the option of installing a padlock.

The display shows the following information: the current position of the device (ON or OFF), the temperature inside the drive box, the number of switching cycles performed, and the current supply voltage of the motor circuit (24 V). The voltage is measured during the last cycle of switching on or disconnecting the device.

NEA

2. Advantages

The NEA-02 motor drive is equipped with an electronic controller responsible for engine control, communication with the remote telemechanics controller, thermostat and display.

Electronic engine control allowed for the complete elimination of all contact elements (contactors, relays), and thus the problem of worn contacts and jamming moving elements is eliminated. Tarnished contacts reduce the power of the drive, which results in an extension of the cycle time of switching on or disconnecting the device, and in extreme cases, the drive does not work completely.

The electronic controller has several overvoltage and anti-interference protections, thanks to which it is well protected and guarantees correct operation and that it will not turn on by accident.

An additional advantage of using an electronic controller is the gentle start of the engine, thanks to which in the initial phase of starting the driving engine there is no current "shock", which significantly shortens the life of the batteries. The controller also allows dynamic braking of the engine after reaching the set position of the electric device, which does not mechanically overload the device and cables.

Thanks to the installed thermostat controlling the heater (230 V), the drive maintains optimal working conditions inside the housing.

The built-in display shows the following information: current position of the device

(ON or OFF), temperature inside the drive box, number of switching cycles performed, and current supply voltage of the motor circuit (24 V). The voltage that was measured during the last cycle of switching on or disconnecting the device (low voltage may indicate either a bad battery condition or a contact problem on the power cables).

The electronic circuits and the motor are protected against moisture, which has a significant impact on the life of the drive. All metal parts are covered with anti-corrosion protection or made of corrosion-resistant materials.

A lockable cabinet provides good protection against weather conditions and unauthorized access to the drive.

There is lighting inside the box to facilitate assembly operations after dark. Both the cabinet lighting and the display turn off automatically when the door is closed.

The drives can set the operating range of the electric apparatus up to 320°.

A simple mechanical structure using proven mechanisms combined with modern electronics gives the entire machine a service life of up to 5,000 switching cycles, a large rated torque of 70 Nm (max. 300 Nm), operational reliability, and shortened emergency shutdown duration.

In the event of a power outage, manual switching is possible.

Small dimensions and low weight of the drive. Adapted to the needs of the Polish Energy Industry.



3. Technical data

Parameter name	Unit	Value
1. Rated supply voltage of the control circuits and the motor	V	DC 24
2. Current consumption of control circuits during standby	A	0,12
3. Current consumption of control circuits and motor during switching	A	25
4. Rated power supply voltage of the heating system	V	AC 230
5. Power of the heating system	W	30
6. Total gear ratio from engine to drive	i	97,8:1
7. Transmission of the gear unit from the crank to the drive	l	32:1
8. Operating temperature range	°C	-40 .. +50
9. Temperature range inside the housing	°C	+5 .. +85
10. Storage temperature range	°C	-25 .. +50
11. Recommended rotation range of the driving cable	°	140 .. 320
12. Rated torque	Nm	70
13. Opening time	s	< 1,5
14. Closing time	s	< 1,5
15. Degree of protection of the housing	IP	54
16. Weight without batteries	kg	21
17. Height	mm	450
18. Width	mm	450
19. Depth	mm	300

4. Construction and principle of operation

The motor drive includes:

- 250 W DC motor;
- worm gear 10:1;
- mechanical locking mechanism of the entire drive;
- manual drive mechanism;
- limit switches and position sensors;
- terminal strip for connecting power circuits;
- microprocessor electronic controller;
- control panel lighting;
- heater controlled by an electronic thermostat.

COVER

The cover is made of an aluminium sheet covered with a layer of epoxy powder paint. The door is sealed with a silicone gasket. The cover design ensures the interior protection level is IP54. There is a sensor next to the door that signals the door opening to the remote operator and switches on the lighting inside the cover and the display on the control panel.

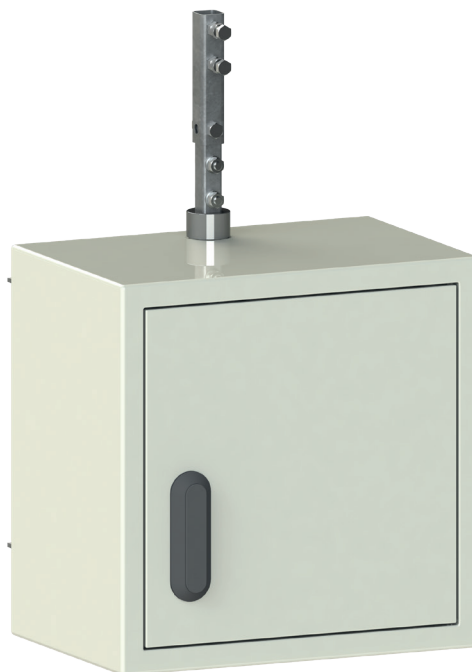

MECHANICAL PART

The mechanical system with the gearbox is mounted at four points on the rear part of the housing. The drive uses a hermetic worm gear working in oil with an initial gear integrated with the engine. The gearbox is equipped with elements enabling mechanical and electrical locking of the drive.

ELECTRICAL AND ELECTRONIC PART

The drive is equipped with an electronic automation system using unipolar power transistors. A PWM soft-start system is used to limit the motor starting current. The switching on and switching off time is limited by a timer to 3 seconds. Moreover, to precisely position the drive when stopped in the extreme position, the system is equipped with dynamic braking.

The drive position limit switches are located on the lower part of the gearbox, and the drive position adjustments are made possible by cams mounted on the output shaft connected to the device cable.

All elements used to manoeuvre the drive locally are located on the front panel. The system is equipped with a 30 W heater regulated by an electronic thermostat.

The electronic system has the following list of controls and signals.

- Remote control open
- Remote control close
- Signalling, manual control
- Remote control signalling
- Mechanical lock signalling

The electric motor drives the output shaft connected to the drive cable and limit switch elements through two gearboxes. As a result of the rotation of the output shaft, the cams mounted on it switch the limit switches.

The rotation range can be adjusted depending on your needs in the range from 0° to 320° (recommended range 140°... 320°).

- Position indication on
- Position indication disabled
- Door opening signal
- Signalling bad battery condition

The drive can be locked both electrically and mechanically.

The drive can be blocked by setting the operation selection switch located on the front panel of the drive - when the switch is in the middle position ("disengaged"), electrical manoeuvring of the drive is impossible. Inserting the crank into the hole automatically blocks the possibility of electrical control, both remote and local, regardless of the position of the operation selection switch.

A mechanical lock which, by moving the lock lever, blocks the operation of the drive while allowing the installation of a pad-lock. This is a situation when teams work on the line and it is very important in terms of their safety to prevent accidental closing of the cut-off switch. Manual manipulation of the cut-off switch is then impossible.

Opening the door automatically blocks the remote control until it is closed.

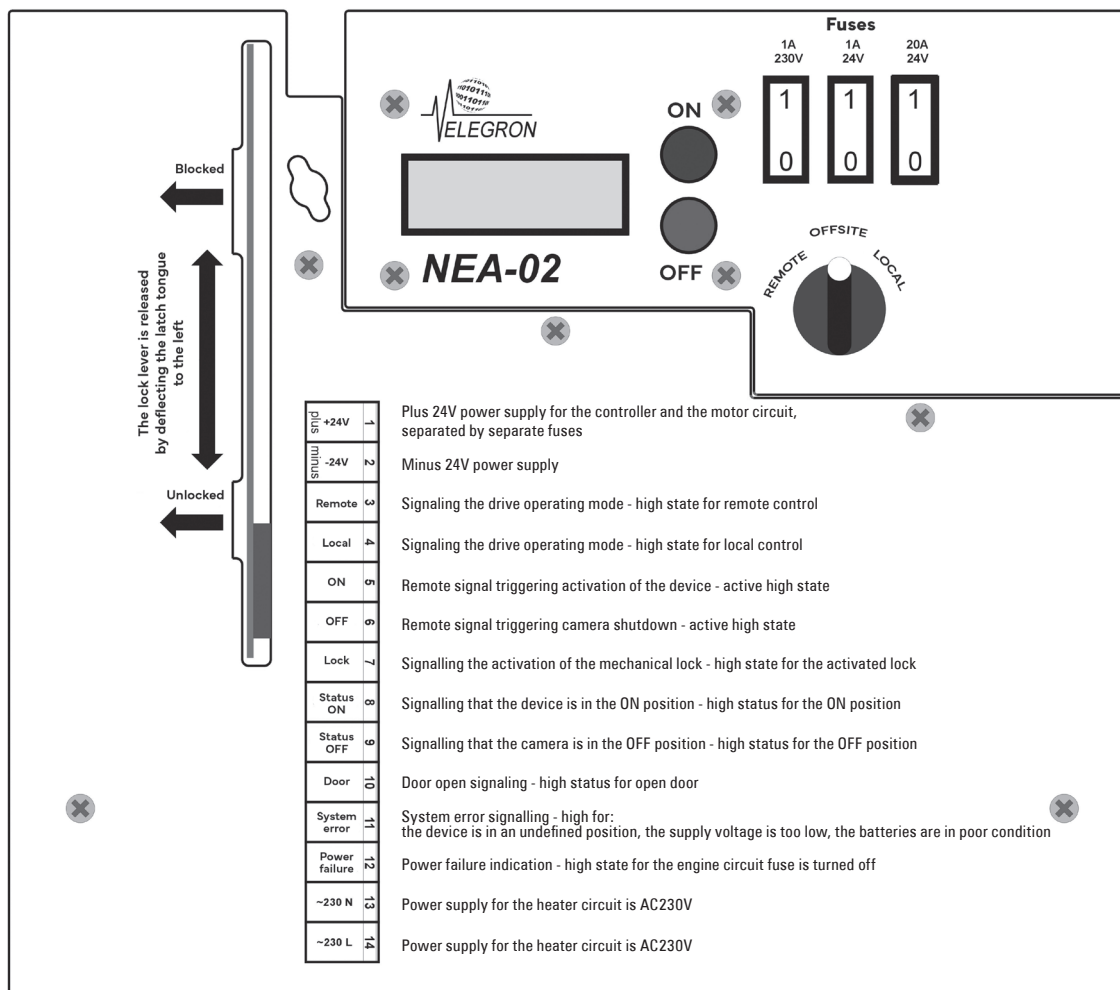

BLOCK DIAGRAM

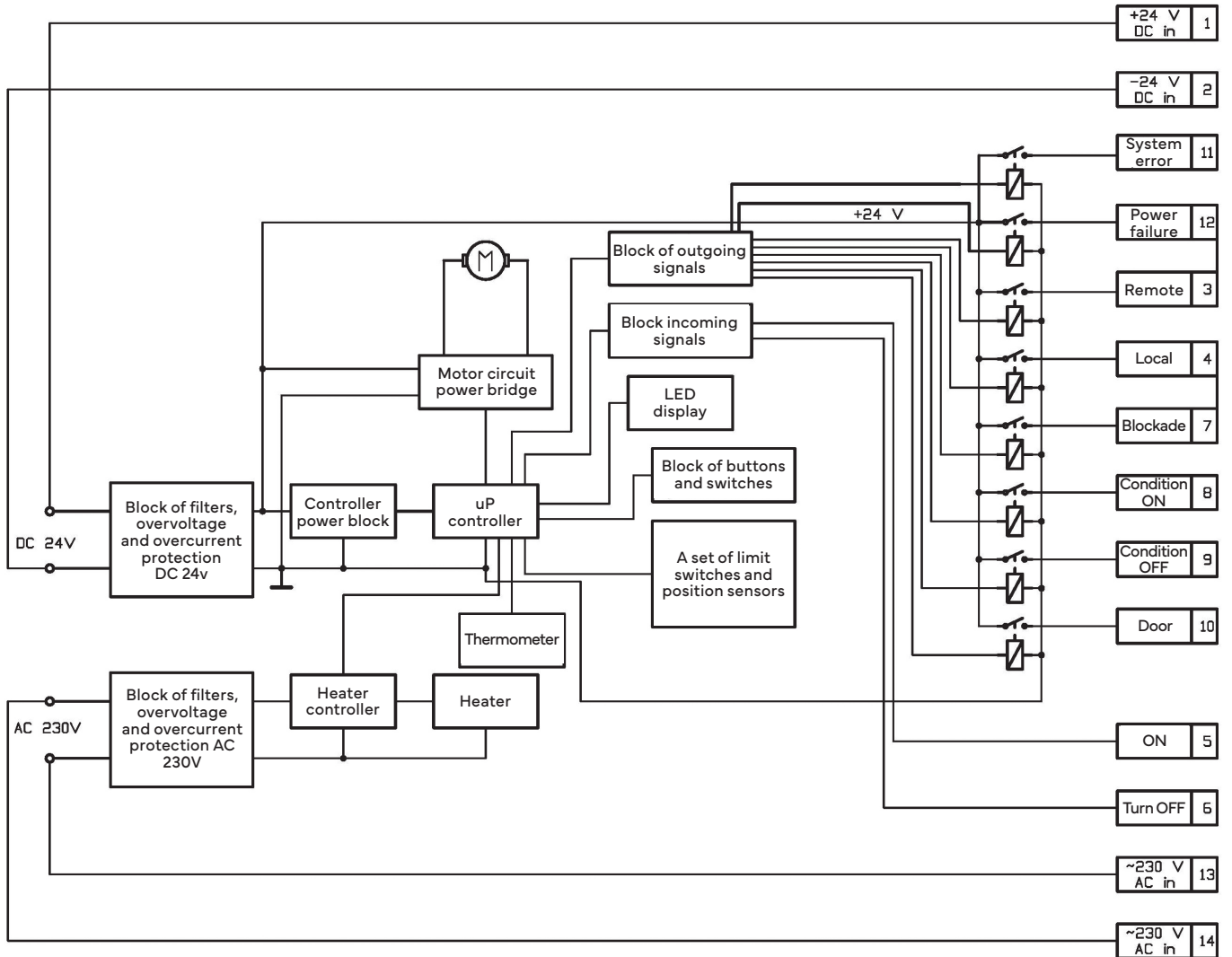

5. Maintenance, periodic inspections and repairs

The design of the drive ensures failure-free operation of the device for 10 years. All steel elements of the drive are galvanized. Ongoing inspections and inspections are not required.

Once a year is recommended:

- checking the reliability of the drive power supply,
- checking the correct operation and fastening of the end switches, in case of looseness, correct the position and improve the fastening,
- checking the correct operation of the switch when there is a rank in the manual drive socket,

- checking the condition of the worm gear and its possible cleaning and lubrication,
- checking the choking condition of the cables,
- checking the condition of the screw connections of the drive transmission system,
- heating system control,
- checking the operation of the door opening sensor.

Repairs to the drive should be carried out using original spare parts.

6. Technical acceptance

The product has been subjected to appropriate inspection procedures by the manufacturer. When receiving the devices, the user is obliged to check the completeness of the equipment.

7. Warranty terms

The manufacturer provides a warranty for the product covering a period of 24 months from the date of installation, but no longer than 36 months from the date of sale, provided that the drive is installed and operated following the instructions.

8. Transport and storage

During transport, reloading and storage, the drive should be in the position marked on the packaging and should not be exposed to mechanical damage. The drive can be transported by any means of transport in a covered state.

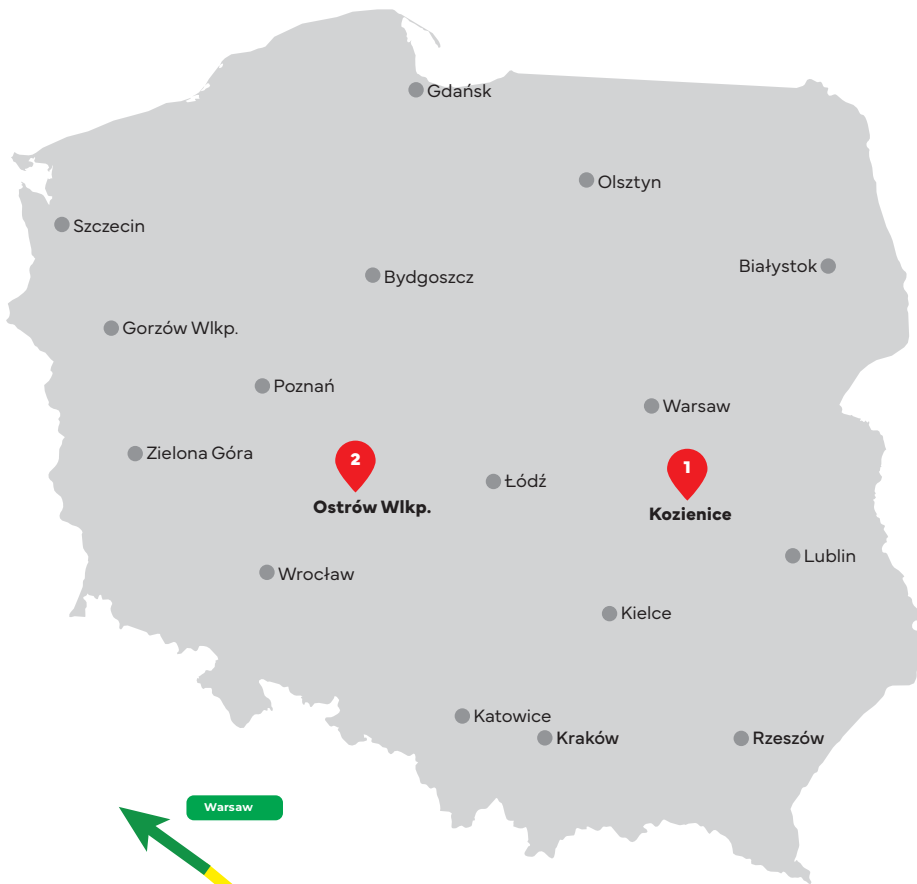

ALPAR - Headquarters
Łuczynów 98
26-900 Kozienice, Poland
tel. +48 48 614 61 14



ALPAR - SALES OFFICE
Nowa 8A
63-400 Ostrów Wielkopolski, Poland
tel. +48 530 906 662 | +48 530 244 868





HEADQUARTERS:

Łuczynów 98 | 26-900 Kozienice, Poland
tel. +48 48 614 6114

SALES OFFICE:

ul. Nowa 8A | 63-400 Ostrów Wielkopolski, Poland
tel. +48 530 906 662 | +48 530 244 868

www.alpar.pl

email: sekretariat@alpar.pl