

**ACCESSORIES  
FOR LOW-VOLTAGE  
OVERHEAD LINES**



# AWARDS

---



## TABLE OF CONTENTS

---

### ***Accessories for low-voltage overhead lines***

1. Connection end holder .....	2
2. End holders.....	6
3. Straight-through and corner clamps.....	7
4. Hook screw and nut hooks .....	10
5. Spun pole holders with hook.....	11
6. Expansion hook screw, expansion screw, and turnbuckles.....	12
7. Distance hooks and hangers.....	13
8. Hook holders with plate and for rods.....	14
9. Rods and rod holders .....	15
10. Crossarms and brackets for insulated conductors.....	16
11. Insulation piercing connectors (IPCs).....	18
12. Surge arrester clamps .....	22
13. Surge arresters.....	23
14. Surge arresters with clamps.....	26
15. SPIN spacer clamp.....	26
16. Single holders U0, U1, and U2.....	27
17. Single holders U0, U1, and U2 for spun poles.....	27
18. Holders U0, U1, and U2 for spun poles E.....	28
19. Holders U0, U1, and U2 for low-voltage concrete poles .....	29
20. Clamp for conduit and cable on low-voltage concrete poles.....	30
21. Distance clamp .....	31
22. Pipe and cable holder for spun pole.....	31
23. Wall-mounted holders U0, U1, and U2.....	32
24. Low-voltage disconnecter mounting structure.....	33
25. Lamp brackets.....	34
26. Brackets for arms (for E-type poles, low-voltage concrete poles, and wall-mounted).....	37
27. Overhead fuses BN, BNA.....	42
28. Cable pole connectors ZKS.....	44
29. Low voltage overhead insulators.....	44
30. THS hook rods.....	44
31. Straight-through, end, and corner structures.....	45
32. Heavy-duty KM-type structures (brackets).....	46
33. TKS shackles.....	47
34. Structures for stork nests.....	48
35. Single-clevis connectors, wedges and spacers.....	50
36. Bolt and U-bolt clamps and hangers.....	51
37. U-bolt end clamps and connectors.....	52
38. Current clamps and loop clamps .....	53
39. Energy lock, keys, rod cap, supporting insulator.....	54
40. Steel tapes, flexible terminals, insulated connectors.....	55
41. Tools for installing selected accessories .....	56

### Connection end holder 2x16-35

Z101

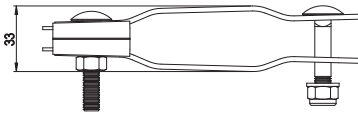
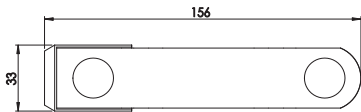

#### Construction:

The 2x16-35 connection end holder consists of the following components:

- Hook – hot-dip galvanized steel.
- Clamping parts – made of a new generation of plastics resistant to UV radiation and atmospheric conditions.
- M8 bolt - of suitable strength hot-dip galvanized.
- Springs made of spring wire, zinc-coated.

#### Application:

Used in insulated power systems in AsXS(n) overhead cables. They are used to secure these cables to building walls and poles using standard hooks.

Technical parameters: cable cross-section 2x16-35, tightening torque 22 Nm and allowable load of 7 kN.

Cat. no.	Cable crossection	Tightening torque	Pack pcs.	Minimum breaking load (MBL)	Weight [kg/pc]
Z101	2x(16-35)	22 Nm	100	7 kN	0.25

### Connection end holder 4x16-35

Z102

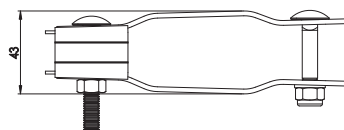
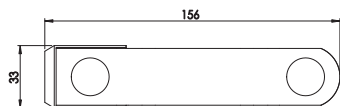
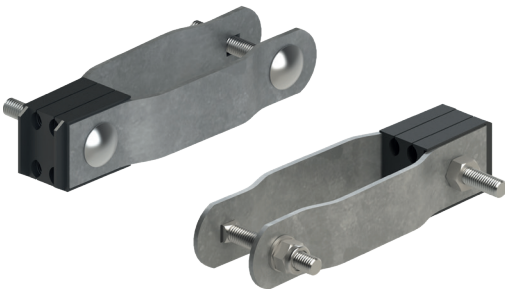

#### Construction:

The 4x16-35 connection end holder consists of the following components:

- Hook - hot-dip galvanized steel.
- Clamping parts – made of a new generation of plastics resistant to UV radiation and atmospheric conditions.
- M8 bolt - of suitable strength hot-dip galvanized.
- Springs made of spring wire, zinc-coated.

#### Application:

Used in insulated power systems in AsXS(n) overhead cables. They are used to secure these cables to building walls and poles using standard hooks.

Technical parameters: cable cross-section 4x16-35, tightening torque 22 Nm and allowable load of 14 kN.

Cat. no.	Cable crossection	Tightening torque	Pack pcs.	Minimum breaking load (MBL)	Weight [kg/pc]
Z102	4x(16-35)	22 Nm	100	14 kN	0.27

End holder 2x25-35

Z4031

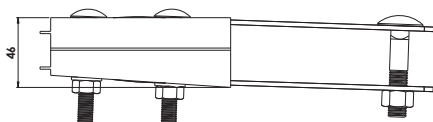
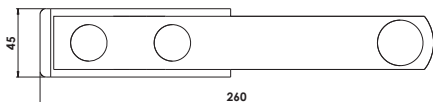

**Construction:**

- The holder's load-bearing elements are made of alloy steel and protected with hot-dip galvanizing.
- The elements supporting the cable are made of a new generation of plastics resistant to UV radiation and weather conditions.
- The material is weatherproof and UV-resistant.

**Application:**

Used in insulated power systems in AsXS(n) overhead cables. They are used to secure these cables to the poles using standard hooks.

Technical parameters: cable cross-section 2x25-35, allowable load 10 kN.

Nr kat.	Cable crosssection	Tightening torque	Minimum breaking load (MBL)	Weight [kg/pc]
Z4031	2x(25-35)	44 Nm	10 kN	0.74

End holder 4x25-50  
End holder 4x70-120

Z403  
Z404

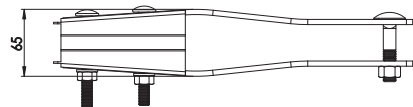
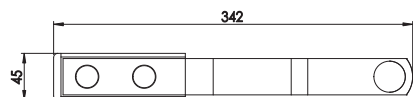

**Construction:**

- The elements supporting the cable are made of a new generation of plastics resistant to UV radiation and weather conditions.
- The elements holding the cable are made of plastic.

**Application:**

Used in insulated power systems in AsXS(n) overhead cables. They are used to secure these cables to the poles using standard hooks.

Technical parameters: cable cross-section 4x25-50, allowable load 10 kN, cable cross-section 4x70-120, allowable load 16 kN.

Nr kat.	Cable crosssection	Tightening torque	Minimum breaking load (MBL)	Weight [kg/pc]
Z403	4x(25-50)	44 Nm	10 kN	0.90
Z404	4x(70-120)	44 Nm	16 kN	1.28

## Connection end holder 2x16-35

Z201

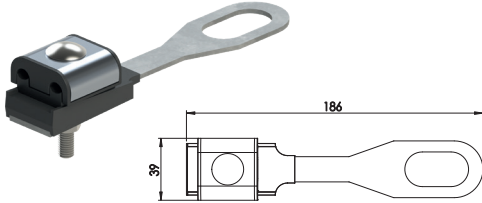

Z201Z

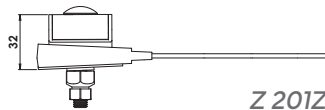
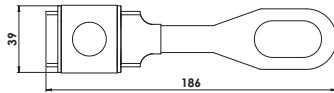
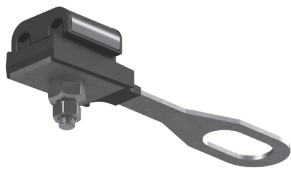
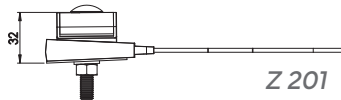
**Construction:**

The 2x16-35 connection end holder consists of the following components:

- Aluminium section made of a special alloy – corrosion-resistant.
- Hook - hot-dip galvanized steel.
- Clamping parts – made of a new generation of plastics resistant to UV radiation and atmospheric conditions.
- M8 bolt - of suitable strength hot-dip galvanised.
- Springs made of spring wire, zinc-coated.
- The Z201Z clamp is equipped with a shear nut.

**Application:**

Used in insulated power systems in AsXS(n) overhead cables. They are used to secure these cables to building walls and poles using standard hooks.

Technical parameters: cable cross-section 2x16-35, tightening torque 22 Nm allowable load 7.7 kN.

Cat. no.	Cable crossection	Tightening torque	Pack pcs.	Minimum breaking load (MBL)	Weight [kg/pc]
Z201	2x(16-35)	22 Nm	100	7.7 kN	0.16
Z201Z	2x(16-35)	22 Nm	100	7.7 kN	0.16

*the clamp is equipped with a shear nut*

## Connection end holder 4x16-35

Z202

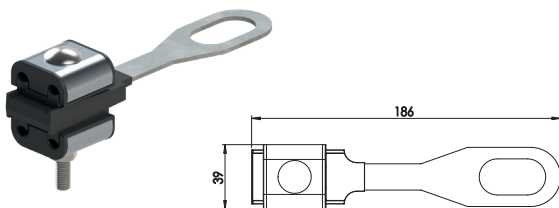

Z202Z

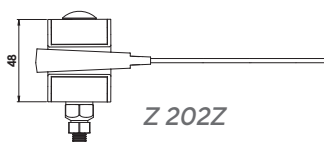
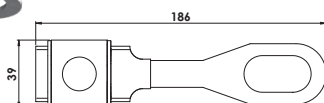
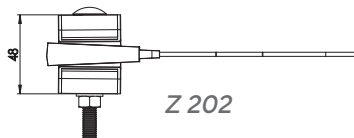
**Construction:**

The 4x16-35 connection end holder consists of the following components:

- Aluminium section made of a special alloy – corrosion-resistant.
- Hook - hot-dip galvanized steel.
- Clamping parts – made of a new generation of plastics resistant to UV radiation and atmospheric conditions.
- M8 bolt - of suitable strength hot-dip galvanised.
- Springs made of spring wire, zinc-coated.

**Application:**

Used in insulated electrical power systems in AsXS(n) overhead cables. They are used to secure these cables to building walls and poles using standard hooks.

Technical parameters: cable cross-section 4x16-35, tightening torque 22 Nm and allowable load of 12.2 kN.

Cat. no.	Cable crossection	Tightening torque	Pack pcs.	Minimum breaking load (MBL)	Weight [kg/pc]
Z202	4x(16-35)	22 Nm	100	12.2 kN	0.17
Z202Z	4x(16-35)	22 Nm	100	12.2 kN	0.17

*the clamp is equipped with a shear nut*

Connection end holder 2x16-35

ZD201

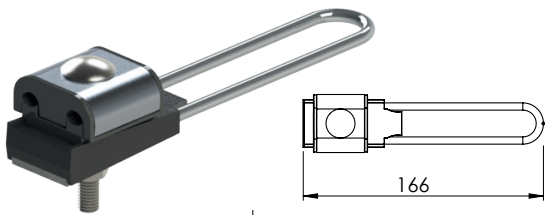

ZD201Z

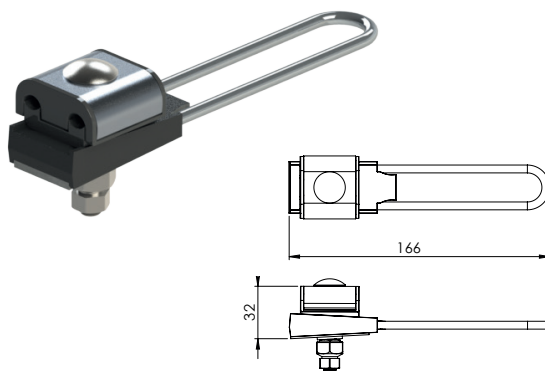

**Construction:**

The 2x16-35 connection end holder consists of the following components:

- Hook - stainless steel.
- Clamping parts – made of a new generation of plastics resistant to UV radiation and atmospheric conditions.
- M8 bolt - of suitable strength hot-dip galvanised.
- Springs made of spring wire, zinc-coated.

**Application:**

Used in insulated electrical power systems in AsXS(n) overhead cables. Attached to building walls and poles using standard hooks.

Cat. no.	Cable crossection	Tightening torque	Pack pcs.	Minimum breaking load (MBL)	Weight [kg/pc]
ZD201	2x(16-35)	22 Nm	100	11 kN	0.173
ZD201Z	2x(16-35)	22 Nm	100	11 kN	0.173
<i>the clamp is equipped with a shear nut</i>					

Connection end holder 4x16-35

ZD202

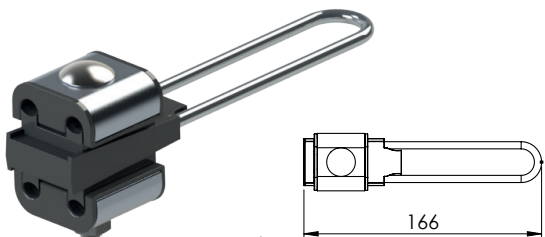

ZD202Z

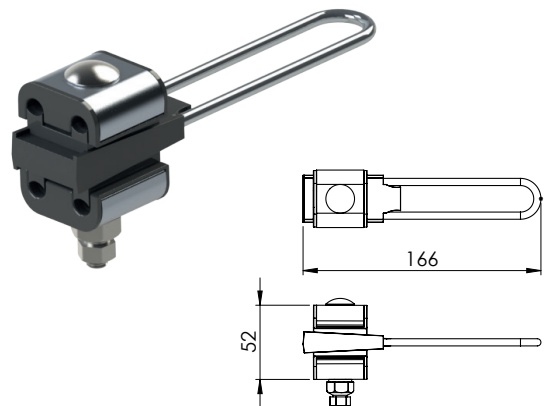

**Construction:**

The 4x16-35 connection end holder consists of the following components:

- Hook - stainless steel.
- Clamping parts – made of a new generation of plastics resistant to UV radiation and atmospheric conditions.
- M8 bolt - of suitable strength hot-dip galvanised.
- Springs made of spring wire, zinc-coated.

**Application:**

Used in insulated electrical power systems in AsXS(n) overhead cables. Attached to building walls and poles using standard hooks.

Cat. no.	Cable crossection	Tightening torque	Pack pcs.	Minimum breaking load (MBL)	Weight [kg/pc]
ZD202	4x(16-35)	22 Nm	100	20 kN	0.27
ZD202Z	4x(16-35)	22 Nm	100	20 kN	0.27
<i>the clamp is equipped with a shear nut</i>					

## End holder 2x25-35

SPIN402

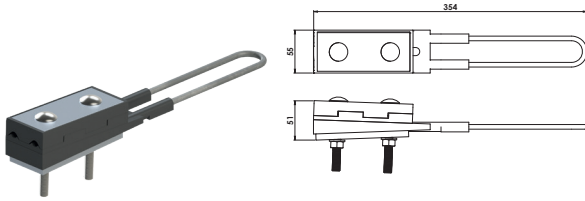

SPIN402Z

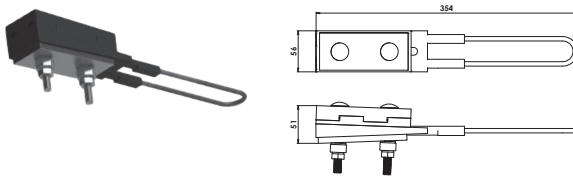
**Construction:**

- The holder's load-bearing elements are made of alloy steel and galvanized.
- The elements supporting the cable are made of a new generation of plastics resistant to UV radiation and weather conditions, which are housed in special corrosion-resistant aluminium.

**Application:**

Used in insulated power systems in AsXS(n) overhead cables. They are used to secure these cables to the poles using standard hooks.

Technical parameters: cable cross-section 2x25-35 allowable load 10.5 kN.

Nr kat.	Cable crossection	Tightening torque	Minimum breaking load (MBL)	Weight [kg/pc]
SPIN 402	2x(25-35)	44 Nm	10.5 kN	0.80
SPIN 402Z	2x(25-35)	44 Nm	10.5 kN	0.80

*the clamp is equipped with a shear nut*

## End holder 4x70-120

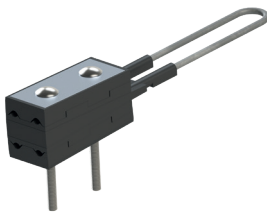
SPIN 403  
SPIN 404SPIN403Z  
SPIN404Z**Construction:**

- The holder's load-bearing elements are made of alloy steel and galvanized.
- The elements supporting the cable are made of a new generation of plastics resistant to UV radiation and weather conditions, which are housed in special corrosion-resistant aluminium.

**Application:**

Used in insulated power systems in AsXS(n) overhead cables. They are used to secure these cables to the poles using standard hooks.

Technical parameters: cable cross-section 4x70-120 or 4x25-70.

Nr kat.	Cable crossection	Tightening torque	Minimum breaking load (MBL)	Weight [kg/pc]
SPIN 403	4x(25-70)	44 Nm	44 kN	0.91
SPIN 403Z	4x(25-70)	44 Nm	44 kN	0.91

*the clamp is equipped with a shear nut*

SPIN 404	4x(70-120)	44 Nm	72 kN	1.25
SPIN 404Z	4x(70-120)	44 Nm	72 kN	1.25

*the clamp is equipped with a shear nut*

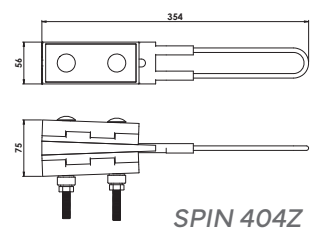
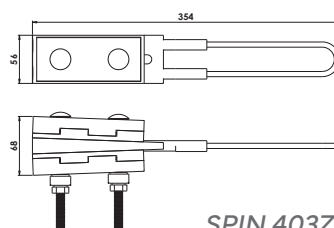
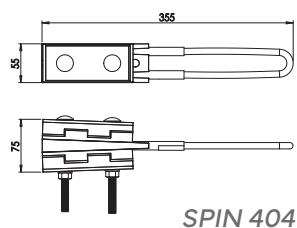
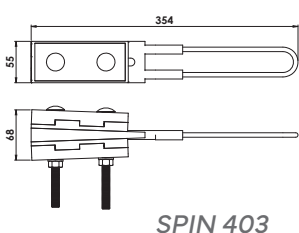

Universal straight-through 2x25-4x70

Z224

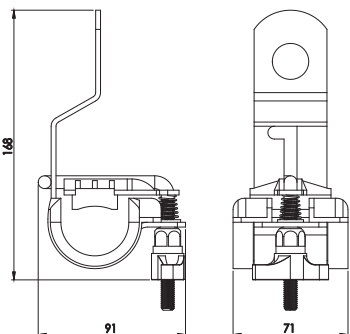
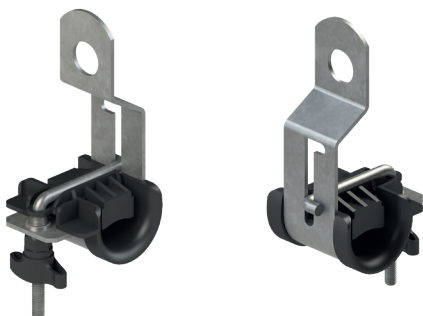

**Construction:**

- The lug is made of appropriately profiled steel sheet, providing the strength required to secure AsXS(n) cables ranging from 2x25 mm<sup>2</sup> to 4x70 mm<sup>2</sup>.
- M8 clamping bolt – hot-dip galvanized, with appropriate strength.
- UV-resistant and weatherproof plastic insert.
- The clamp is equipped with a shear nut.

**Application:**

Used for through suspension of insulated overhead AsXS(n) cables with cross-sections from 2x25 to 4x70 mm<sup>2</sup> on standard hook bolts. Used for bends between 180°-150°.

Cat. no.	Used for AsXS(n) cables	Minimum breaking load (MBL)	Weight [kg/pc]
Z224	from 2x25 to 4x70	7 kN	0.31

Universal straight-through clamp 2x25-4x120 Strong

Z224M

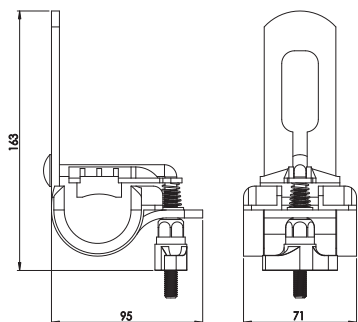

**Construction:**

- The lug is made of suitably profiled steel sheet, providing the necessary strength to secure AsXS(n) cables ranging from 2x25 mm<sup>2</sup> to 4x120 mm<sup>2</sup>.
- M8 clamping bolt – hot-dip galvanized, with appropriate strength.
- UV-resistant and weatherproof plastic insert.

**Application:**

Used for through suspension of insulated overhead AsXS(n) cables with cross-sections from 2x25 to 4x120 mm<sup>2</sup> on standard lug bolts. Used for bends between 180°-120°.

Cat. no.	Used for AsXS(n) cables	Minimum breaking load (MBL)	Weight [kg/pc]
Z224M	from 2x25 to 4x120	24 kN	0.46

Straight-through clamp 2/4x16-120

Z2050

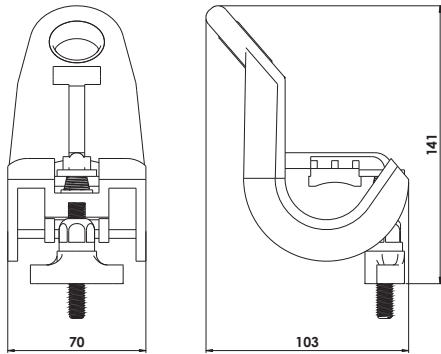

**Construction:**

- The lug is made of a new generation of plastics resistant to UV radiation and weather conditions. Due to the special properties of the plastic and the appropriate design of the straight-through clamp, it exhibits greater strength compared to traditionally used clamps made of steel or aluminium.
- The mounting hole of the straight-through clamp for the lug bolt is equipped with a reinforcing bushing made of stainless steel.
- The clamping U-bolt is equipped with a shear nut that ensures proper installation when tightened to 5 Nm.

**Application:**

Used for through suspension of insulated overhead ASXS(n) conductors with cross-sections from 16 to 120 mm<sup>2</sup> on standard lug bolts. Used for bends between 180°-165°. For 2/4x16-70 cables, for 4x95, 4x120 cables straight sections.

Cat. no.	Used for AsXS(n) cables	Minimum breaking load (MBL)	Weight [kg/pc]
Z2050	2/4x16-120	12 kN	0.19

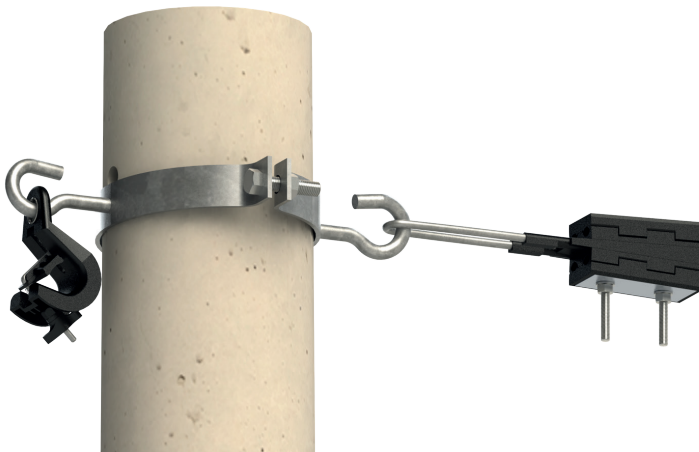

Wall-mounted universal straight-through clamp 2x25-4x120

Z224P

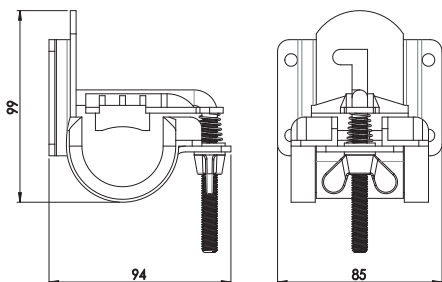
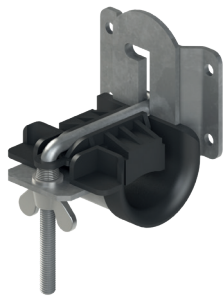

**Construction:**

- The lug is made of properly profiled steel sheet, providing the strength required to secure AsXS(n) cables ranging from 2x25 mm<sup>2</sup> to 4x120 mm<sup>2</sup>.
- M8 clamping bolt – hot-dip galvanized, with appropriate strength.
- UV-resistant and weatherproof plastic insert.

**Application:**

Used for through suspension of insulated overhead AsXS(n) cables with cross-sections from 2x25 to 4x120 mm<sup>2</sup> on flat surfaces using expansion plugs.

Cat. no.	Used for AsXS(n) cables	Minimum breaking load (MBL)	Weight [kg/pc]
Z224P	from 2x25 to 4x120	1.5 kN	0.35

SPIN 320 corner clamp

Z226

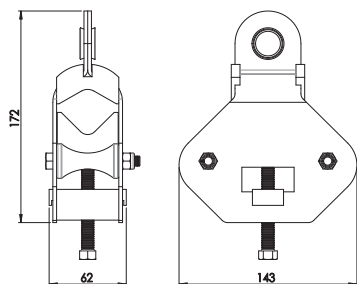
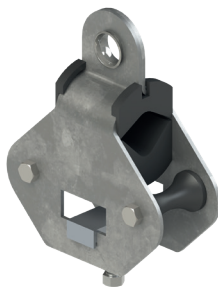

**Construction:**

- Body - hot-dip galvanized steel.
- Rubber inserts and mounting rollers made of UV-resistant plastic.

**Application:**

Used for through suspension of insulated overhead AsXS(n) cables with cross-sections from 16 to 120 mm<sup>2</sup> in straight lines or at angles from 0° to 90°, on standard lug bolts. Most commonly used on corner poles, where the cable changes direction.

Cat. no.	Used for AsXS(n) cables	Minimum breaking load (MBL)	Weight [kg/pc]
Z226	4x95+2x35, 4x120	60 kN	1

## Hook screw M16 | M20

SH16L160

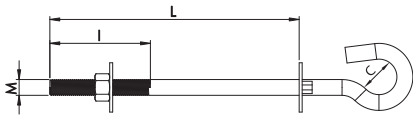
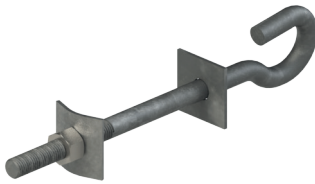
**Construction:**

- S235 steel bar: square washers, M16 or M20 nut.
- Hot-dip galvanized.
- The threads on the hook bolts are rolled.

**Application:**

They are used for suspending strain and straight-through clamps that secure self-supporting insulated conductors on E and low-voltage concrete poles, building walls, and similar structures.

Cat. no.	M mm	L mm	Thread length C mm	Allowable load in kN		Weight [kg/pc]
				F <sub>x</sub>	F <sub>y</sub>	
SH16L160	M16	160	100	12.1	3.5	0.67
SH16L180	M16	180	100	12.1	3.5	0.75
SH16L200	M16	200	100	12.1	3.5	0.73
SH16L220	M16	220	100	12.1	3.5	0.77
SH16L250	M16	250	100	12.1	3.5	0.82
SH16L280	M16	280	100	12.1	3.5	0.89
SH16L300	M16	300	100	12.1	3.5	0.89
SH16L320	M16	320	100	12.1	3.5	0.90
SH16L350	M16	350	100	12.1	3.5	0.96
SH16L400	M16	400	100	12.1	3.5	1.05
SH16L420	M16	420	100	12.1	3.5	1.10
SH16L500	M16	500	100	12.1	3.5	1.20
SH16L600	M16	600	100	12.1	3.5	1.41
SH20L160	M20	160	100	14.6	6	1.05
SH20L200	M20	200	100	14.6	6	1.15
SH20L220	M20	220	100	14.6	6	1.20
SH20L250	M20	250	100	14.6	6	1.26
SH20L280	M20	280	100	14.6	6	1.31
SH20L300	M20	300	100	14.6	6	1.38
SH20L320	M20	320	100	14.6	6	1.44
SH20L350	M20	350	100	14.6	6	1.53
SH20L420	M20	420	100	14.6	6	1.74
SH20L480	M20	480	100	14.6	6	1.83

## Nut hook M12 | M16 | M20

HN12, HN16, HN20

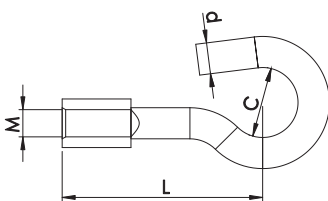
**Construction:**

- S235 steel bar.
- Hot-dip galvanized.

**Application:**

Used for suspending straight-through and end clamps of the second circuit of the line.

Cat. no.	d	C	L	m	Allowable load in kN		Weight [kg]
					F <sub>x</sub>	F <sub>y</sub>	
HN12	12	40	70	12	6.5	2.5	0.30
HN16	16	40	76	16	12.1	3.5	0.43
HN20	20	40	80	20	12.1	6	0.65

Spun pole holder with hook M16 / M20

S50



**Application:**

They are used for suspending strain and straight-through clamps securing self-supporting insulated conductors on spun poles without holes.

Cat. no.	Name	Ø of the clamp (from - to)	Weight [kg/pc]
S504	Spun pole bracket with M16 hook	155-190 mm	1.25
S50	Spun pole bracket with M16 hook	200-240 mm	1.44
S50/263	Spun pole bracket with M16 hook	263 mm	1.77
S506	Spun pole holder with M20 hook	155-190 mm	1.53
S502	Spun pole holder with M20 hook	200-240 mm	1.65
S502/263	Spun pole holder with M20 hook	263 mm	2.18

Corner spun pole holder M16 / M20

S501



**Application:**

They are used for suspending strain and straight-through holder securing self-supporting insulated conductors on spun poles without holes. Most commonly used when making two or more branches from a single pole.

Cat. no.	Name	Ø of the clamp (from - to)	Weight [kg/pc]
S505	Spun pole holder – corner type with 2x M16 hooks	155-190 mm	1.64
S501	Spun pole holder – corner type with 2x M16 hooks	200-240 mm	1.76
S501/263	Spun pole holder – corner type with 2x M16 hooks	263 mm	2.10
S507	Spun pole holder – corner type with 2x M20 hooks	155-190 mm	2.08
S503	Spun pole holder – corner type with 2x M20 hooks	200-240 mm	2.15
S503/263	Spun pole holder – corner type with 2x M20 hooks	263 mm	2.55

S501/3

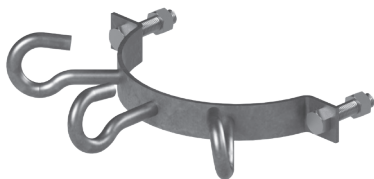

Cat. no.	Name	Ø of the clamp (from - to)	Weight [kg/pc]
S505/3	Spun pole holder – corner type with 3x M16 hooks	155-190 mm	1.95
S501/3	Spun pole holder – corner type with 3x M16 hooks	200-240 mm	2.00
S501/263/3	Spun pole holder – corner type with 3x M16 hooks	263 mm	2.35
S507/3	Spun pole holder – corner type with 3x M20 hooks	155-190 mm	2.63
S503/3	Spun pole holder – corner type with 3x M20 hooks	200-240 mm	2.70
S503/263/3	Spun pole holder – corner type with 3x M20 hooks	263 mm	3.10

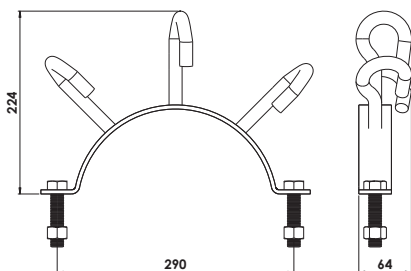

## Hook expansion screw M12 | M16

S3031

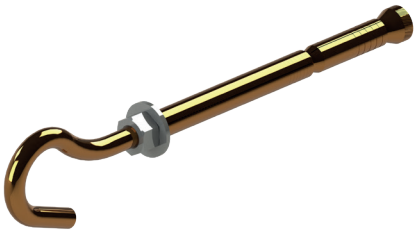
**Construction:**

Used for fastening end clamps on flat surfaces, such as building walls.

Cat. no.	Name	Weight [kg/pc]
S303K	Hook expansion screw M12 L-110	0.340
S303	Hook expansion screw M12 L-210	0.364
S3031	Hook expansion screw M16 L-300	0.636

## Expansion screw M12 | M16

S3041

**Construction:**

Used for fastening components on flat surfaces, such as building walls.

Cat. no.	Name	Weight [kg/pc]
S304	Expansion screw M12 L-110/170 mm (thread/whole)	0.328
S3041	Expansion screw M16 L-130/170 mm (thread/whole)	0.600

## Bottle screw M8 | M10 | M12 | M16

S3052

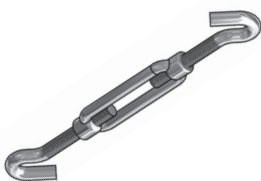
**Construction:**

Used for tensioning and adjusting the tension of strain cables and wires.

Cat. no.	Name	Weight [kg/pc]
S305	Bottle screw M8	0.154
S3051	Bottle screw M10	0.283
S3052	Bottle screw M12	0.418
S3053	Bottle screw M16	0.945

Distance hook M16 and M20

HD16  
HD20

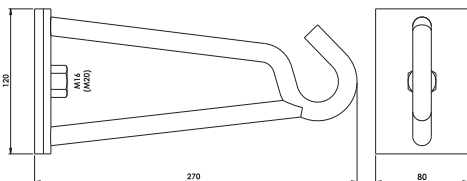
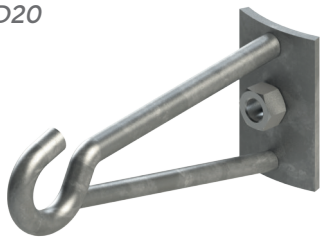

HD16 i HD20

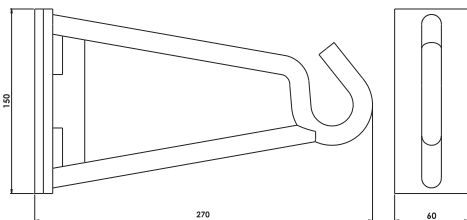

HDT16, HDT20

**Construction:**

- Steel bar - S235.
- Steel flat bar - S235.
- Nut.

**Application:**

Nut-spacer hooks mounted on round and flat surfaces are used for suspending straight-through and corner clamps in overhead insulated multi-circuit lines.

Cat. no.	Name	F <sub>x</sub> kN	F <sub>y</sub> kN	Weight [kg/pc]
HD16	Distance hook M16	7.5	3.5	1.52
HD20	Distance hook M20	13.5	6.0	1.90
HD16T	Distance hook attached with steel strap Ø 16	7.5	3.5	1.52
HD20T	Distance hook attached with steel strap Ø 20	13.5	6.0	1.90

Suspension hook M12 | M16 | M20 for fastening with steel tape

HZ12  
HZ16  
HZ20

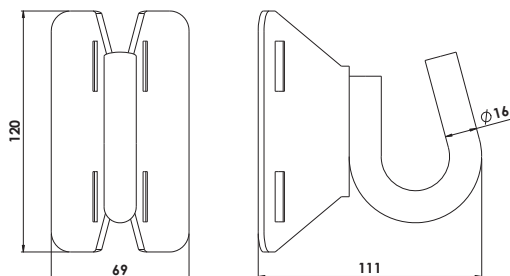

HZ16

**Construction:**

- Steel bar - S235.
- Sheet steel - S235.

**Application:**

Hook for round poles, used to suspend strain and straight-through clamps on round poles without holes. They are fixed with a stainless-steel tape.

Cat. no.	Name	F <sub>x</sub> kN	F <sub>y</sub> kN	Weight [kg/pc]
HZ12	M12 suspension hook for fastening with steel tape	6.3	2.3	0.45
HZ16	M16 suspension hook for fastening with steel tape	12.1	3.5	0.579
HZ20	M20 suspension hook for fastening with steel tape	14.6	6.0	0.9

### Hook holder with plate

UHP12  
UHP16



#### Construction:

- Steel plate - S235.
- Steel bar - S235.

#### Application:

Used for suspending end clamps on flat surfaces, such as building walls. The spacing in the clamps ranges up to 700 mm.

Cat. no.	Name	Fx kN	Fy kN	Weight [kg/pc]
UHP12	Hook holder with plate M12	4.5	2.1	0.55
UHP16	Hook holder with plate M16	7.5	3.5	0.70

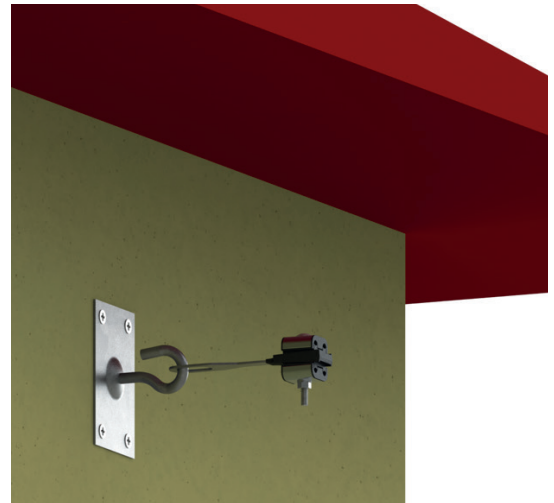
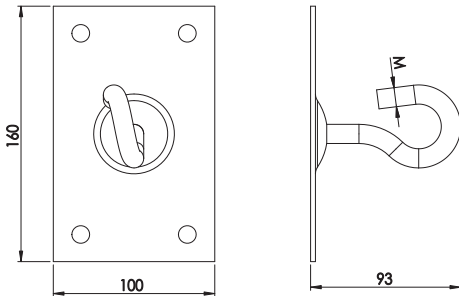

### Rod Hook holder

UHS12  
UHS12(2)  
UHS16  
UHS16(2)

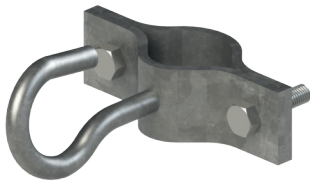

#### Construction:

- Steel bar - S235.
- Steel flat bar - S235.
- Nut.

#### Application:

Used for suspending end clamps on building rods.

Cat. no.	Name	Fx kN	Fy kN	Weight [kg/pc]
UHS12	Rod hook holder M12	4.2	1.8	0.75
UHS16	Rod hook holder M16	7.5	3.5	0.80
UHS12(2)	Rod hook holder 2" M12	4.2	1.8	0.63
UHS16(2)	Rod hook holder 2" M16	7.5	3.5	0.91

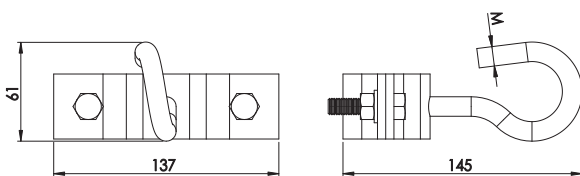

LV volted connecting rod

WRP



Cat. no.	Name	Weight [kg/pc]
WRP-1/2/50	Rod WRP-1 hook M16 2m Ø 50	6.80
WRP-1/2,5/50	Rod WRP-1 hook M16 2.5m Ø 50	8.10
WRP-1/3/50	Rod WRP-1 hook M16 3m Ø 50	10.40
WRP1/4/50	Rod WRP-1 hook M16 4m Ø 50	10.10
WRP-2/2/60	Rod WRP-2 hook M16 2m Ø 60	8.90
WRP-2/2,5/60	Rod WRP-2.5 hook M16 2m Ø 60	9.50
WRP-2/3/60	Rod WRP-2 hook M16 3m Ø 60	12.70
WRP-2/4/60	Rod WRP-2 hook M16 4m Ø 60	16.50

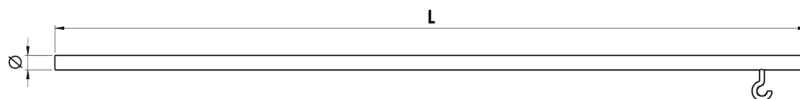

Rod holder

UR-1/300



Cat. no.	Name	Weight [kg/pc]
UR-1/200	Rod holder UR-1 L-200	3.10
UR-1/300	Rod holder UR-1 L-300	3.90
UR-1/400	Rod holder UR-1 L-400	4.70
UR-1/500	Rod holder UR-1 L-500	5.40
UR-1/700	Rod holder UR-1 L-700	7.00
UR-1/800	Rod holder UR-1 L-800	8.01
UR-1/1000	Rod holder UR-1 L-1000	9.70

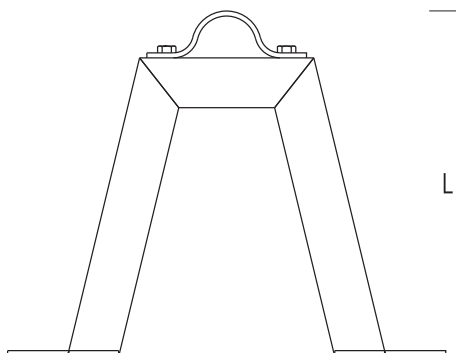
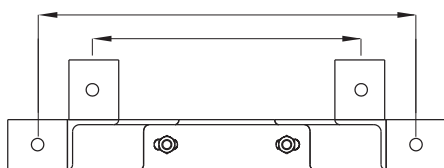

### Insulated wire installation crossarm

PZI-2

**Construction:**

- Bracket made of S235 steel.
- Hot-dip galvanized.

**Application:**

Used for suspending end clamps that secure self-supporting insulated conductors for double-circuit lines on spun poles of type E. Intended for use with 2 pcs. of M20x120 hook bolts and 2 pcs. of SPIN-type clamps.

Cat. no.	Name	Stirrup bolt Ø (from-to)
PZI-2	Crossarm attaching insulated wires	200-240 mm
PZI-2/263	Crossarm attaching insulated wires	263 mm

**Note:**

Additionally required for mounting:

- 1x OB-31 bracket (for PZI-2),
- 1x OB-34 bracket (for PZI-2/263).

### Insulated wire installation crossarm

PZI-3

**Construction:**

- Crossarm made of S235 steel.
- Hot-dip galvanized.

**Application:**

Used for suspending end clamps securing self-supporting insulated conductors for double-circuit lines, as well as a suspension clamp for insulated conductors on a spun pole of type E. Installed in combination with 2 pcs of M20x120 hook bolts, 2 pcs of SPIN-type clamps, 1 pc of suspension clamp, and 1 pc of eye hook.

Cat. no.	Name	Stirrup bolt Ø (from-to)
PZI-3	Crossarm attaching insulated wires	200-240 mm
PZI-3/263	Crossarm attaching insulated wires	263 mm

**Note:**

Additional components required for securing:

- 1x O3/A bracket + 2x M16x240 bolt (for PZI-3),
- 1x OB-34 bracket (for PZI-3/263).

*Insulated wire installation arm*

WZI-2

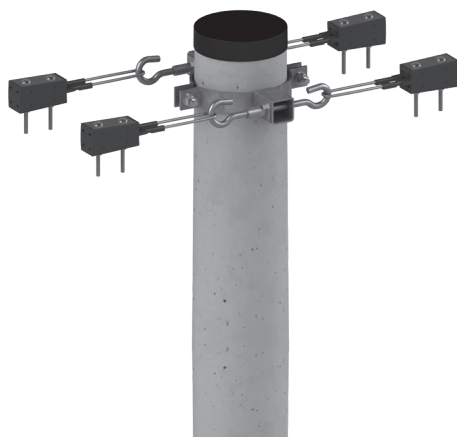
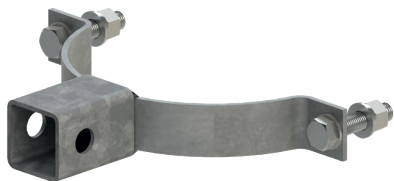

**Construction:**

- Bracket made of S235 steel.
- Hot-dip galvanized.

**Application:**

Used for suspending end clamps securing self-supporting insulated conductors in double-circuit lines on a type E spun pole. Installed in combination with 2 pcs M20x160 hook bolts, 2 pcs M20 eye nuts, and 4 pcs SPIN-type clamps.

Cat. no.	Name	Ø of the clamp (from - to)
WZI-2	Insulated wires installation bracket	200-240 mm
WZI-2/263	Insulated wires installation bracket	263 mm

*Insulated wire installation Crossarm*

PZI-1

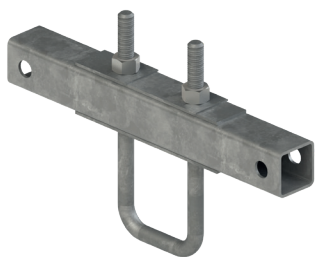

**Construction:**

- Crossarm made of S235 steel.
- Hot-dip galvanized.

**Application:**

Used for suspending end clamps securing self-supporting insulated conductors in double-circuit lines on a low-voltage pole. Used in combination with 2 pcs M20x120 hook bolts, 2 pcs M20 eye nuts, and 4 pcs SPIN-type clamps.

Cat. no.	Name
PZI-1	Crossarm attaching insulated wires

### One-sided insulation-piercing clamp AL 16-120

Z206



Z206Z

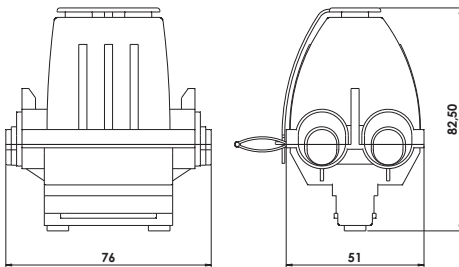

#### Construction:

- Housing – made of plastic resistant to UV radiation and other atmospheric factors.
- Insulation piercing connectors – made of aluminium alloy section.
- Hex socket screws, class 8/8 – hot-dip galvanized.
- Springs – made of spring steel, hot-dip galvanized.
- Clamp contacts are filled with contact grease.

#### Application:

Used for branching from bare AL cables to insulated conductors of type AsXS and AsXS(n) with cross-sections from 16 to 120 mm<sup>2</sup>. It is most often used when making branches from old AL lines to insulated lines.

Cat. no.	Main cable	Branch cable	Pack pcs.	Tightening torque	Weight [kg/pc]
Z206	16-120 AL	16-95 AL	100	22 Nm	0.14
Z206Z	16-120 AL	16-95 AL	100	22 Nm	0.14
<i>the clamp is equipped with a shear nut</i>					
Z4	- compatible with surge arrester				
Z4Z	- compatible with surge arrester				
<i>the clamp is equipped with a M12 shear bolt</i>					

### Two-sided insulation-piercing clamp AL 16-120

Z2061



Z2061Z

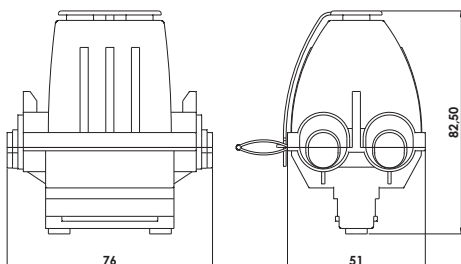
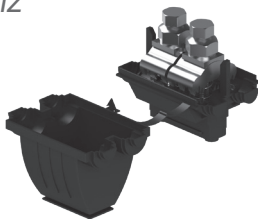

#### Construction:

- Housing – made of plastic resistant to UV radiation and other atmospheric factors.
- Insulation piercing connectors – made of aluminium alloy section.
- Hex socket screws, class 8/8 – hot-dip galvanized.
- Springs – made of spring steel, hot-dip galvanized.
- Clamp contacts are filled with contact grease.

#### Application:

Used for branching from insulated conductors of type AsXS and AsXS(n) with cross-sections from 16 to 120 mm<sup>2</sup>.

Cat. no.	Main cable	Branch cable	Pack pcs.	Tightening torque	Weight [kg/pc]
Z2061	16-120 AL	16-95 AL	100	22 Nm	0.14
Z2061Z	16-120 AL	16-95 AL	100	22 Nm	0.14
<i>the clamp is equipped with a shear nut</i>					
Z3	- compatible with surge arrester				
Z3Z	- compatible with surge arrester				
<i>the clamp is equipped with a M12 shear bolt</i>					

One-sided one-screw insulation-piercing clamp AL 16-120

Z106

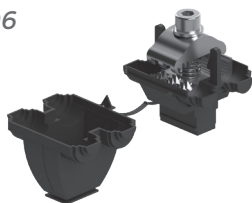

Z106Z

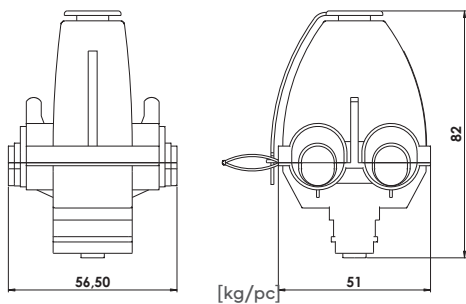
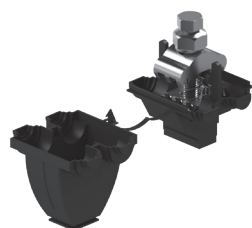

**Construction:**

- Housing – made of plastic resistant to UV radiation and other atmospheric factors.
- Insulation piercing connectors – made of aluminium alloy section.
- Hex socket bolt, class 8/8 – hot-dip galvanized.
- Springs – made of spring steel, hot-dip galvanized.
- Clamp contacts are filled with contact grease.

**Application:**

Used for branching from bare aluminium (AL) cables to insulated conductors of types AsXS and AsXS(n) with cross-sections from 16 to 120 mm<sup>2</sup>. It is most often used when making branches from old AL lines to insulated lines.

Cat. no.	Main cable	Branch cable	Pack pcs.	Tightening torque	Weight [kg/pc]
Z106	16-120 AL	16-95 AL	100	22 Nm	0.076
Z106Z	16-120 AL	16-95 AL	100	22 Nm	0.076
<i>the clamp is equipped with a M12 shear bolt</i>					
Z106Cu	1,5-120 Al-Cu	1,5-95 Al-Cu	100	22 Nm	0.076

Two-sided one-screw insulation-piercing clamp AL 16-120

Z1061

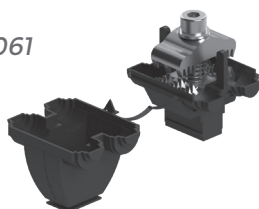

Z1061Z

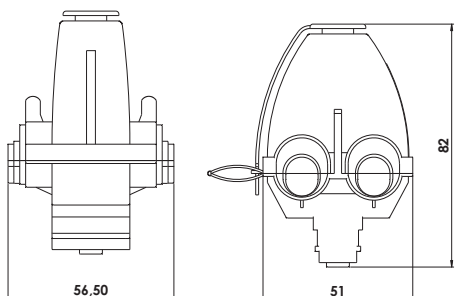
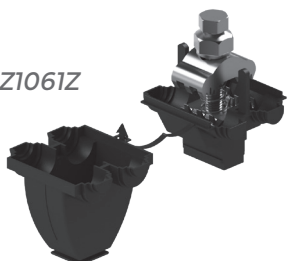

**Construction:**

- Housing – made of plastic resistant to UV radiation and other atmospheric factors.
- Insulation piercing connectors – made of aluminium alloy section.
- Hex socket bolt, class 8/8 – hot-dip galvanized.
- Springs – made of spring steel, hot-dip galvanized.
- Clamp contacts are filled with contact grease.

**Application:**

Used for branching from insulated conductors of types AsXS and AsXS(n) with cross-sections from 16 to 120 mm<sup>2</sup>.

Cat. no.	Main cable	Branch cable	Pack pcs.	Tightening torque	Weight [kg/pc]
Z1061	16-120 AL	16-95 AL	100	22 Nm	0.076
Z1061Z	16-120 AL	16-95 AL	100	22 Nm	0.076
<i>the clamp is equipped with a M12 shear bolt</i>					
Z1061Cu	1,5-120 Al-Cu	1,5-95 Al-Cu	100	22 Nm	0.076

## Insulation-piercing clamps Z208...Z series

Z208Z

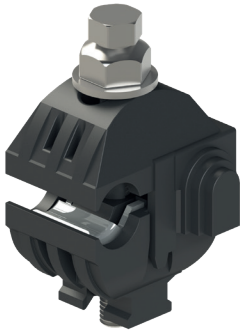

Z2081Z

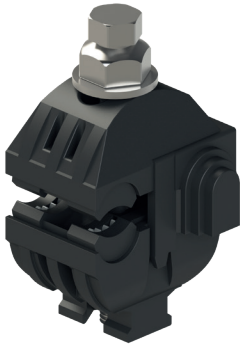

Z2082Z

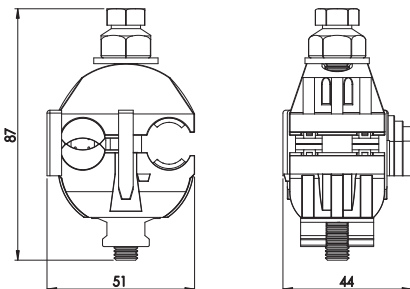
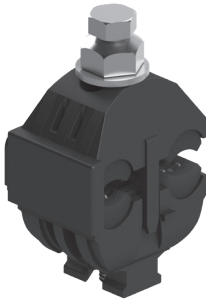
**Construction:**

- The clamp's hermetic housing is made of plastic resistant to UV radiation and other atmospheric factors such as moisture and water.
- The clamp jaws feature a curtain-ridge design. They are made of tinned copper alloy and are factory-filled with contact grease as standard.
- The clamping screws are corrosion-protected by hot-dip galvanizing. The clamping nuts are made of aluminium. To prevent both nuts from being tightened simultaneously by accident, a separating O-ring is used.
- Connector Z208Z: one-sided insulation piercing, 16–95 / 1.5–50 mm<sup>2</sup>.
- Connector Z2081Z: double-sided insulation piercing, 16–120 / 16–20 mm<sup>2</sup>.
- Connector Z2082Z: double-sided insulation piercing, 16–95 / 1.5–50 mm<sup>2</sup>.

**Application:**

Connectors designed for branching from bare and insulated overhead cables to insulated aluminium-copper (Al-Cu) cables within the cross-section range of 1.5 to 120 mm<sup>2</sup>.

**Description of the connectors:**

The connectors from series Z208... Z are the latest product line offered by ALPAR. They feature improved mechanical and electrical connections compared to previous models, resulting in extended service life and operational reliability. Thanks to their optimized design, these new solutions allow for safe installation of the clamps under live conditions. The shape of the lower part of the connector enables mounting in a front-end wrench. The connectors are equipped with an additional so-called shear nut – after tightening with the specified torque (14 Nm or 18 Nm), the connector pierces the insulation, and the nut shears off. If reuse is necessary, the connector can be loosened or retightened using a certified torque wrench.

**Advantages:**

1. Connectors are standardly equipped with seals protecting against moisture ingress.
2. Extended service life of connectors due to additional protection of jaws by tin plating and filling with contact grease.
3. No access to current-carrying components ensured by complete insulation of the clamping bolt from the connector jaws.
4. Full conductor cross-section range: main cables from 16 to 120 mm<sup>2</sup>; branches from 1.5 to 50–120 mm<sup>2</sup>.
5. Short order fulfilment time and competitive pricing.
6. Connectors feature a shear bolt, eliminating the need for certified torque wrenches during installation.
7. Despite using an M12 shear bolt, the connectors can be reused multiple times.

Cat. no.	Construction	Main cable	Branch cable	Pack pcs.	Tightening torque	Weight [kg/pc]
Z208Z	one-sided	Al-Cu 16-95	AL-Cu 1,5-50	100	14 Nm	0.132
<i>the clamp is equipped with a M12 shear bolt</i>						
Z2081Z	double-sided	Al-Cu 16-120	AL-Cu 16-120	100	18 Nm	0.132
<i>the clamp is equipped with a M12 shear bolt</i>						
Z2082Z	double-sided	Al-Cu 16-95	AL-Cu 1,5-50	100	14 Nm	0.132
<i>the clamp is equipped with a M12 shear bolt</i>						



**NOTE: All connectors of the Z208...Z series are designed for direct installation with BN-25A and BN-63A overhead fuses, as well as with surge arresters using flexible tube-type Z2 cables.**

Insulation-piercing clamps, Z208... series

Z208

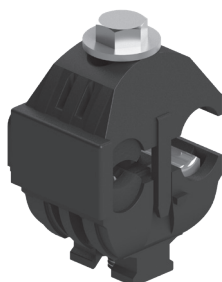

**Construction:**

- The connector's hermetic housing is made of plastic resistant to UV radiation and other atmospheric factors such as moisture and water.
- The clamp jaws feature a curtain-ridge design. They are made of tinned copper alloy and are factory-filled with contact grease as standard.
- The clamping screws are corrosion-protected by hot-dip galvanizing.
- Connector Z208: one-sided insulation piercing, 16–95 / 1.5–50 mm<sup>2</sup>.
- Connector Z2081: double-sided insulation piercing, 16–120 / 16–120 mm<sup>2</sup>.
- Connector Z2082: double-sided insulation piercing, 16–95 / 1.5–50 mm<sup>2</sup>.

**Application:**

Connectors used for branching from bare and insulated overhead cables to insulated Al-Cu cables with cross-sectional areas ranging from 1.5 to 120 mm<sup>2</sup>.

Z2081



**Description of the connectors:**

The Z208 series connectors are the latest product line offered by ALPAR. They feature improved mechanical and electrical connections compared to previous models, resulting in increased durability and service life. Thanks to their optimized design, these new solutions allow for safe installation of the clamps under live conditions. The shape of the lower part of the connector enables mounting in a front-end wrench.

**Advantages:**

1. Connectors are standardly equipped with seals protecting against moisture ingress.
2. Extended service life of connectors due to additional protection of jaws by tin plating and filling with contact grease.
3. No access to current-carrying components ensured by complete insulation of the clamping bolt from the connector jaws.
4. Full conductor cross-section range: main cables from 16 to 120 mm<sup>2</sup>; branches from 1.5 to 50–120 mm<sup>2</sup>.
5. Short order fulfilment time and competitive pricing.

Z2082

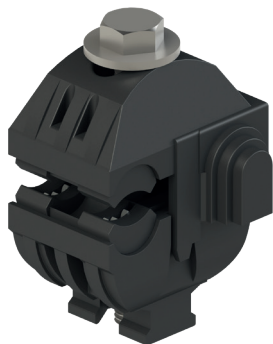

Cat. no.	Construction	Main cable	Branch cable	Pack pcs.	Tightening torque	Weight [kg/pc]
Z208	one-sided	Al-Cu 16-95	AL-Cu 1,5-50	100	14 Nm	0.132
Z2081	double-sided	Al-Cu 16-120	AL-Cu 16-120	100	18 Nm	0.132
Z2082	double-sided	Al-Cu 16-95	AL-Cu 1,5-50	100	14 Nm	0.132

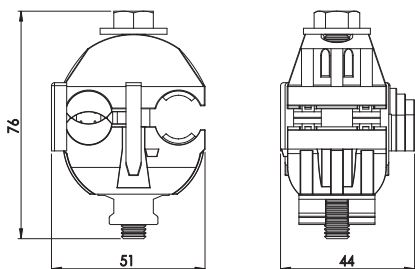

**NOTE:** All connectors of the Z208 series are designed for direct installation with BN-25A and BN-63A overhead fuses, as well as with surge arresters using flexible tube-type Z2 cables.

## Surge arrester clamp

Z41

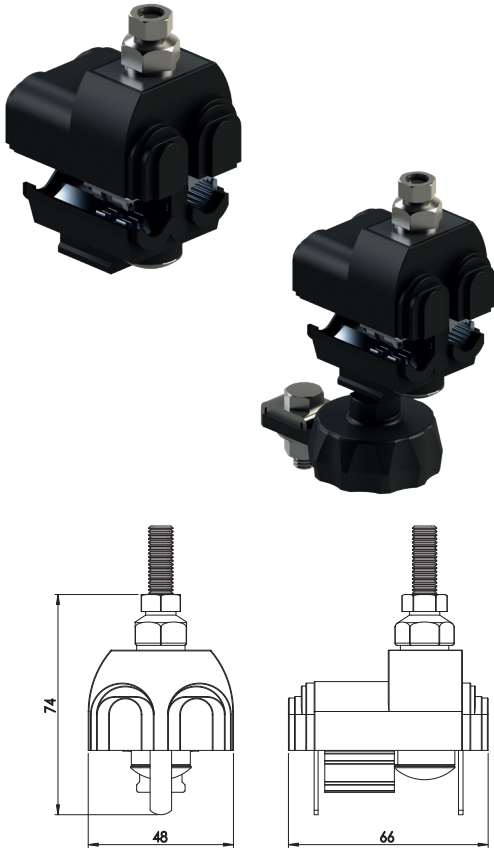
**Construction:**

- The housing is made of plastic resistant to UV radiation and other atmospheric factors.
- The piercing clamps are made of tinned aluminium alloy sections.
- Clamping bolt, class 8.8, hot-dip galvanized.
- Clamp contacts are filled with contact grease.
- The clamp is equipped with a shear nut.

**Application:**

Used for surge arresters and for branching from bare AL cables to insulated conductors of the AsXSn type with cross-sections from 16 to 120 mm. Thanks to the tin-plated clamp jaws, they can be used for AL-Cu cable connections.

Cat. no.	Construction	Main cable	Branch cable	Pack pcs.	Torque	Weight [kg/pc]
Z41	one-sided	16-120 AL-Cu	16-95 AL-Cu	100	22 Nm	0.14

## Surge arrester pipe clamp

Z2

**Application:**

The clamp allows for the installation of a surge arrester on insulated overhead line cables using most insulation piercing connectors.

**Construction:**

Rubber cover protecting the threaded connection between the surge arrester and the end of the "tube"-type clamp.

Steel sleeve with internal M8 thread, hot-dip galvanized.

AsXSn 1x25 conductor, 20 cm or 35 cm in length.

Cat. no.	Overhead line cable crosssection range	Weight [kg/pc]
Z2	16-95 mm <sup>2</sup>	0.036
Z2/350	16-95 mm <sup>2</sup>	0.037

Surge arresters ASA-A "APATOR"



**Construction:**

- The ASA-A type surge arrester incorporates an active component – a varistor – manufactured using a highly specialized technology based on zinc oxide (ZnO) ceramic material with the addition of other metal oxides. These additives, precisely dosed, form semiconductor surface and intergranular layers on the ZnO crystals, stabilizing the varistor’s voltage-current characteristic, which is nonlinear.
- The arrester is manufactured using a direct injection moulding process, applying polyamide directly onto the varistor.

**Operation principle:**

The primary function of the surge arrester is to discharge electrical surges to the ground that may appear on overhead line cables. The arrester, equipped with a varistor, responds to any voltage change at its clamps. Under normal operating voltage, it conducts a current in the microampere range. However, when an electrical surge appears on the line cables — with a potential exceeding the continuous operating voltage  $U_c$  (e.g., from a direct lightning strike or inductive surge) — the arrester immediately diverts the charge to ground, preventing overvoltage that could threaten the insulation of electrical equipment.

Technical parameters	$U_c$ [Vrms]	$NIn$ [kA]	$I_{max}$ [kA]	$OUp$ [Vpeak]	$Up/U_c$
ASA-A500-5	500	5	25	1750	4.0
ASA-A660-5	660	5	25	2650	4.0
ASA-A500-10	500	10	40	1750	4.0
ASA-A660-10	660	10	40	2650	4.0

Cat. no.	Name	Weight [kg/pc]
ASA-A500-5DK	ASA-A500-5 surge arrester with bare line clamp	0.21
ASA-A500-5F2K	ASA-A500-5 surge arrester with double-sided insulation piercing clamp AL16-120	0.30
ASA-A500-5F1K	ASA-A500-5 surge arrester with single-sided insulation piercing clamp AL16-120	0.29
ASA-A660-5DK	ASA-A660-5 surge arrester with bare line clamp	0.21
ASA-A660-5F2K	ASA-A660-5 surge arrester with double-sided insulation piercing clamp AL16-120	0.30
ASA-A660-5F1K	ASA-A660-5 surge arrester with single-sided insulation piercing clamp AL16-120	0.29
ASA-A500-10DK	ASA-A500-10 surge arrester with bare line clamp	0.20
ASA-A660-10DK	ASA-A660-10 surge arrester with bare line clamp	0.21

## Surge arrester BOP-R BEZPOL

**Construction:**

- In the design of the BOP-R type surge arrester, an active component – a varistor – is used. It is manufactured using a highly specialized technology based on zinc oxide (ZnO) ceramic material, with the addition of carefully dosed metal oxides. These additives form semiconductor surface and intergranular layers on the zinc oxide crystals, stabilizing the varistor's nonlinear voltage-current characteristic.
- The arrester is manufactured using a direct injection moulding process, applying polyamide directly onto the varistor.

**Operation principle:**

The primary function of the surge arrester is to divert to ground any electrical charge associated with overvoltage that may occur on overhead line cables. Equipped with a varistor, the arrester responds to any voltage change at its clamps. Under normal operating voltage, it conducts a microampere-level current. However, when a surge with a potential exceeding the continuous operating voltage  $U_c$  appears on the line (e.g. from a direct lightning strike or an inductive surge), the arrester instantly discharges the energy to ground, preventing an overvoltage that could endanger the insulation of electrical equipment.

No.	Cat. no.	Name
1.	BOP-R 0.44/5 ZGL	BOP-R 0.44/5 surge arrester with bare line clamp
2.	BOP-R 0.44/5 Z2P	BOP-R 0.44/5 surge arrester with double-sided insulation piercing clamp AL 16-120 / 16-95
3.	BOP-R 0.44/5 ZIP	BOP-R 0.44/5 surge arrester with one-sided insulation piercing clamp AL 16-120 / 16-95
4.	BOP-R 0.44/10 ZGL	BOP-R 0.44/10 surge arrester with bare line clamp
5.	BOP-R 0.44/10 Z2P	BOP-R 0.44/10 surge arrester with double-sided insulation piercing clamp AL 16-120/16-95
6.	BOP-R 0.44/10 ZIP	BOP-R 0.44/10 surge arrester with one-sided insulation piercing clamp AL 16-120/16-95
7.	BOP-R 0.5/5 ZGL	BOP-R 0.5/5 surge arrester with bare line clamp
8.	BOP-R 0.5/5 Z2P	BOP-R 0.5/5 surge arrester with double-sided insulation piercing clamp AL 16-120/16-95
9.	BOP-R 0.5/5 ZIP	BOP-R 0.5/5 surge arrester with one-sided insulation piercing clamp AL 16-120/16-95
10.	BOP-R 0.5/10 ZGL	BOP-R 0.5/10 surge arrester with bare line clamp
11.	BOP-R 0.5/10 Z2P	BOP-R 0.5/10 surge arrester with double-sided insulation piercing clamp AL 16-120/16-95
12.	BOP-R 0.5/10 ZIP	BOP-R 0.5/10 surge arrester with one-sided insulation piercing clamp AL 16-120/16-95
13.	BOP-R 0.66/5 ZGL	BOP-R 0.66/5 surge arrester with bare line clamp
14.	BOP-R 0.66/5 Z2P	BOP-R 0.66/5 surge arrester with double-sided insulation piercing clamp AL 16-120/16-95
15.	BOP-R 0.66/5 ZIP	BOP-R 0.66/5 surge arrester with one-sided insulation piercing clamp AL 16-120/16-95
16.	BOP-R 0.66/10 ZGL	BOP-R 0.66/10 surge arrester with bare line clamp
17.	BOP-R 0.66/10 Z2P	BOP-R 0.66/10 surge arrester with double-sided insulation piercing clamp AL 16-120/16-95
18.	BOP-R 0.66/10 ZIP	BOP-R 0.66/10 surge arrester with one-sided insulation piercing clamp AL 16-120/16-95

Surge arrester ETITEC A



**Construction:**

- ETITEC A is a spark-gap-free surge arrester, with a ZnO varistor as its main component.
- The varistor is housed in a sealed and robust plastic enclosure resistant to UV radiation.
- The surge arrester is offered in four options: three types with insulated AsXS(n) cables, and one for bare AL lines.

**Application:**

ETITEC A surge arresters are overhead devices used on low-voltage lines to protect equipment installed in the network. They serve as the first level of protection installed in accordance with European standards, which define three or four protection levels: A, B, C, and D. Class A arresters are an essential surge protection stage because they are responsible for handling all external surges up to a maximum level of 6 kV.

**Operation principle:**

The spark-gap-free surge arrester operates upon every occurrence of an overvoltage. The varistor element has a highly nonlinear characteristic. Under normal network operating conditions, when connected between phase and ground, the arrester presents an infinitely high resistance. When an overvoltage occurs, the varistor shifts its operating point along the characteristic curve, causing its resistance to drop to a fraction of its normal value. This causes the surge wave, instead of traveling to the equipment, to be limited and the discharge current to be safely diverted to ground. The surge energy is captured and absorbed by the varistor element. After the surge is suppressed, the varistor returns to its original operating point and awaits the next overvoltage event.

**Technical parameters:**

ETITEC A is produced in four basic versions with rated voltages of 280 V, 500 V, and 660 V, and rated currents of 5 kA and 15 kA. Each version can be equipped with four types of line clamps. The earthing clamp consists of an M8 threaded stud designed for mounting a conductor with a cable lug or earthing clamp.

Cat. no.	Name	Weight [kg/pc]
12990198	ETITEC A 500/5/A with a line clamp for bare conductor lines	0.18
12990199	ETITEC A 500/5/B with double-sided insulation piercing clamp AL16-120	0.26
12991191	ETITEC A 500/5/C with one-sided insulation piercing clamp AL16-120	0.26
12991192	ETITEC A 500/5/D with an insulation-piercing clamp AL-Cu 16-120 with a "tube" type conductor	0.26
12990194	ETITEC A 660/5/A with a line clamp for bare conductor lines	0.18
12990195	ETITEC A 660/5/B with double-sided insulation piercing clamp AL16-120	0.26
12990196	ETITEC A 660/5/C with one-sided insulation piercing clamp AL16-120	0.26
12990197	ETITEC A 660/5/D with an insulation-piercing clamp AL-Cu16-120 with a "tube" type conductor	0.26

We offer surge arresters rated at 500/10 kA and 660/10 kA.

## Insulation piercing clamps with surge arrester ASA

Z2081 +  
Z2 +  
ASA-...-5F2K  
500, 660/5 or 10KA

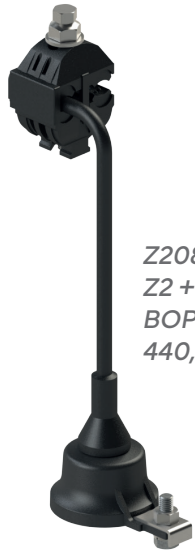
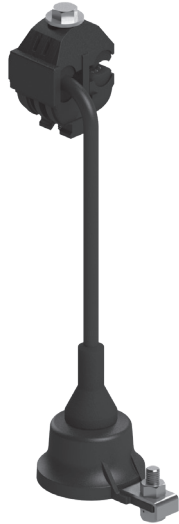

Z2081Z+  
Z2 +  
BOP-R...Z2P  
440, 500, 660/5 or 10KA

Z2081Z+  
Z2...Z2P  
ETITEC  
500, 660/5 or 10KA



### Construction:

#### The set consists of:

- Insulation Piercing Connector (IPC) type Z2081 – Hermetically sealed housing made of UV-resistant plastic, also resistant to other atmospheric factors such as moisture and water.
- The clamp jaws feature a curtain-ridge design. They are made of tin-plated copper alloy and are factory-filled with contact grease.
- Clamping screws are protected against corrosion by hot-dip galvanization.
- Lightning arrester clamp - "tube" type Z2 – Rubber cover protects the threaded connection between the arrester and the end of the "tube" type clamp.
- Steel sleeve with internal M8 thread, hot-dip galvanized AsXS(n) 1x25 cable with a length of 200 mm.
- Low-voltage surge arresters: types ASA, BOP-R, ETITEC, 5F2K.

### Application:

The surge arrester set with an insulation piercing connector (IPC) is designed to provide overvoltage protection against both direct and indirect effects of lightning- and switching-induced surges in low-voltage power systems – from the LV bushing of a MV/LV transformer, through overhead and underground LV lines, their branches, and up to building service connections.

### Advantages:

1. Connectors are standardly equipped with seals protecting against moisture ingress.
2. Extended service life of connectors due to additional protection of jaws by tin plating and filling with contact grease.
3. No access to current-carrying components ensured by complete insulation of the clamping bolt from the clamps' jaws.
4. Full conductor cross-section range: main cables from 16 to 120 mm<sup>2</sup>; branches from 1.5 to 50–120 mm<sup>2</sup>.
5. Short order fulfilment time and competitive pricing.

## SPIN spacer clamp

SPIN 351

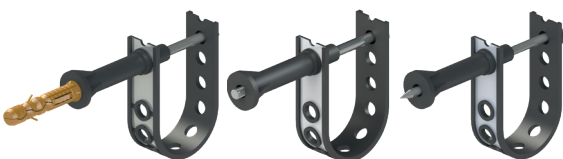

### Application:

For fastening cables and conductors on building walls, racks, poles, etc.

Cat. no.	Max. cable diameter	Allowable load Fy/daN	Fastening element	Weight [kg/pc]
SPIN 350	50	80	Nail 5"	0.040
SPIN 351	50	7.5	Bolt 6x120 with washer	0.045
SPIN 352	50	80	Bolt M 6x90	0.040

Holders U0, U1 and U2

U25 | U50 | U75

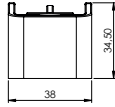
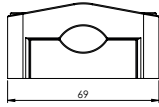

U25

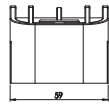
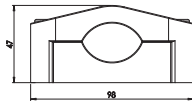

U50

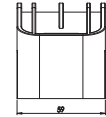
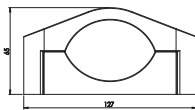

U75

**Construction:**

Black-coloured polyamide, resistant to UV radiation and variable weather conditions.

**Application:**

They are used to fasten cables and conduits with diameters of 12–25 mm, 25–50 mm, and 45–75 mm on flat or other surfaces, such as building walls, steel structures, inside switch cabinets, low-voltage poles, spun poles, etc., depending on the type of base.

**Technical data:**

The materials used in production demonstrate mechanical strength and temperature resistance.

Cat. no.	Name	Bracket range Ø	Weight [kg/pc]
U25	Holder U0 for flat surfaces	12-25 mm	0.040
U50	Holder U1 for flat surfaces	25-50 mm	0.097
U75	Holder U2 for flat surfaces	45-75 mm	0.122

Holders U0, U1 and U2 for spun poles

U25T | U50T | U75T

U25T

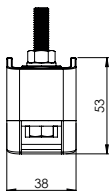
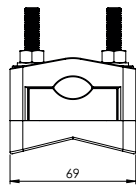

U50T

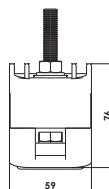
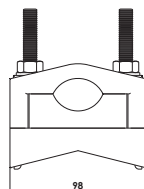
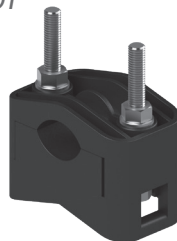

U75T

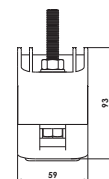
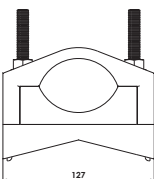
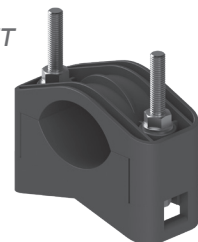

**Construction:**

Black-coloured polyamide, resistant to UV radiation and variable weather conditions.

**Application:**

- Holder U0 for spun pole (tape).
- Holder U25T is used to fasten cables with diameters of 12 to 25 mm to round poles using steel tape.
- Holder U1 for spun pole (tape).
- Holder U50T is used to fasten cables with diameters of 25 to 50 mm to round poles using steel tape.
- Holder U2 for spun pole (tape).
- Holder U75T is used to fasten cables with diameters of 45 to 75 mm to round poles using steel tape.

Cat. no.	Type	Bracket range Ø	Weight [kg/pc]
U25T	Holder U0 for spun pole	12-25 mm	0.115
U50T	Holder U1 for spun pole	25-50 mm	0.273
U75T	Holder U2 for spun pole	45-75 mm	0.317

### Holders U0, U1 and U2 for spun poles E

U25(1)W - (Ø 12-25 mm)  
 U50(1)W - (Ø 25-50 mm)  
 U75(1)W - (Ø 45-75 mm)

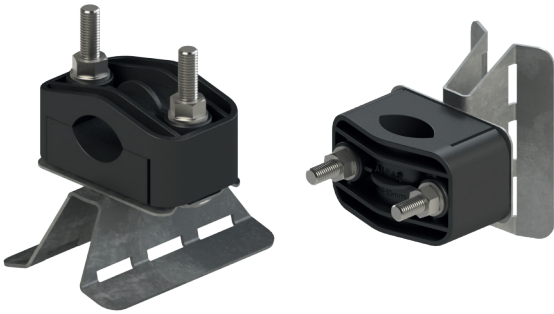

U25(2)W - (Ø 12-25 mm)  
 U50(2)W - (Ø 25-50 mm)  
 U75(2)W - (Ø 45-75 mm)

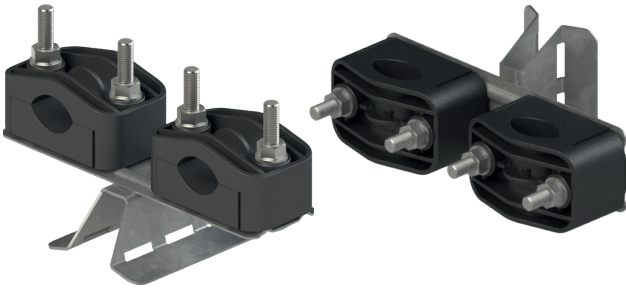

U25(3)W - (Ø 12-25 mm)  
 U50(3)W - (Ø 25-50 mm)  
 U75(3)W - (Ø 45-75 mm)

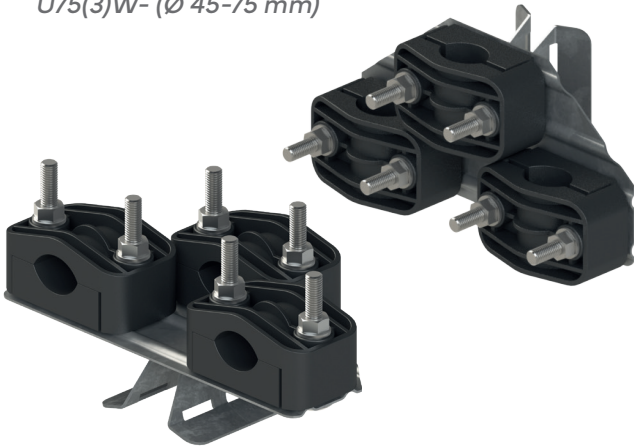

#### Construction:

- Black-coloured polyamide, UV-resistant and weatherproof, and S235 hot-dip galvanized steel. Holder U0 for spun pole.
- The holder U25(1)W is used to fasten cables with diameters of 12 to 25 mm to round poles using steel tape.

#### Holder U1 for spun pole.

- The holder U50(1)W is used to fasten cables with diameters of 25 to 50 mm to round poles using steel tape.

#### Holder U2 for spun pole.

- The holder U75(1)W is used to fasten cables with diameters of 45 to 75 mm to round poles using steel tape.

#### Holder U0 for double spun pole

- The holder U25(2)W is used to fasten 2 cables with diameters of 12 to 25 mm laid on round poles. The holder is attached to the pole with a stainless-steel tape.

#### Holder U1 for double spun pole

- The holder U50(2)W is used to fasten 2 cables with diameters of 25 to 50 mm laid on round poles. The holder is attached to the pole with a stainless-steel tape.

#### Holder U2 for double spun pole.

- The holder U75(2)W is used to fasten 2 cables with a diameter of 45 - 75 mm laid on round poles. The clamp is attached to the pole with a stainless-steel tape.

#### Holder U0 for triple spun pole.

- The holder U25(3)W is used to fasten 2 cables with diameters of 12 to 25 mm laid on round poles. The clamp is attached to the pole with a stainless-steel tape.

#### Holder U1 for triple spun pole.

- The holder U50(3)W is used to fasten 3 cables with diameters of 25 to 50 mm laid on round poles. The clamp is attached to the pole with a stainless-steel tape.

#### Holder U2 for triple spun pole.

- The holder U75(3)W is used to fasten 3 cables with a diameter of 45 - 75 mm laid on round poles. The clamp is attached to the pole with a stainless-steel tape.

Cat. no.	Type	Bracket range Ø	Weight [kg/pc]
U25(1)W	Holder U0 for single spun pole	12-25 mm	0.25
U25(2)W	Holder U0 for double spun pole	12-25 mm	0.458
U25(3)W	Holder U0 for triple spun pole	12-25 mm	0.458
U50(1)W	Holder U1 for single spun pole	25-50 mm	0.59
U50(2)W	Holder U1 for double spun pole	25-50 mm	0.88
U50(3)W	Holder U1 for triple spun pole	25-50 mm	1.42
U75(1)W	Holder U2 for single spun pole	45-75 mm	0.66
U75(2)W	Holder U2 for double spun pole	45-75 mm	1.10
U75(3)W	Holder U2 for triple spun pole	45-75 mm	1.60

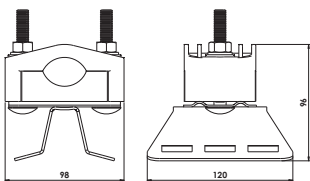

U25(1)W, U50(1)W, U75(1)W

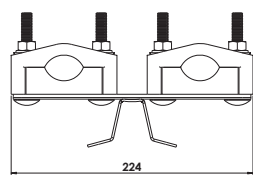

U25(2)W, U50(2)W, U75(2)W

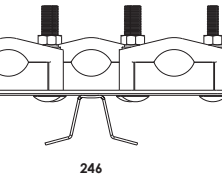
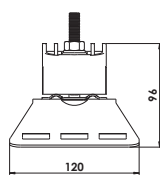

U25(3)W, U50(3)W, U75(3)W

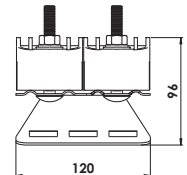

Holders U0, U1 and U2 for low-voltage concrete poles

U50(1)ŽN-bo  
U75(1)ŽN-bo



U25(1)ŽN-zo  
U50(1)ŽN-zo  
U75(1)ŽN-zo



**Construction:**

Black-coloured polyamide, resistant to UV radiation and varying weather conditions, and S235 hot-dip galvanized steel.

**Application:**

They are used for securing cables and conduits with diameters of 12-25 mm, 25-50 mm, and 45-75 mm to low-voltage concrete poles. Offset clamps are used when pole maintenance requires the use of pole climbers. For maintenance performed with aerial lifts, standard clamps without offset are generally used.

**Technical data:**

The materials used in production exhibit very high mechanical and temperature resistance.

U50(2)ŽN-bo  
U75(2)ŽN-bo



U25(2)ŽN-zo  
U50(2)ŽN-zo  
U75(2)ŽN-zo



U50(3)ŽN-bo  
U75(3)ŽN-bo



U25(3)ŽN-zo  
U50(3)ŽN-zo  
U75(3)ŽN-zo

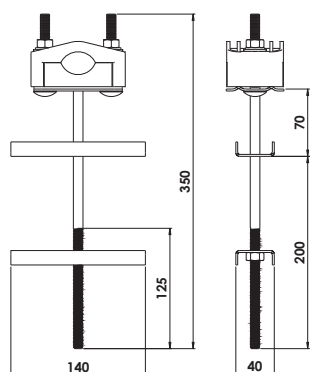
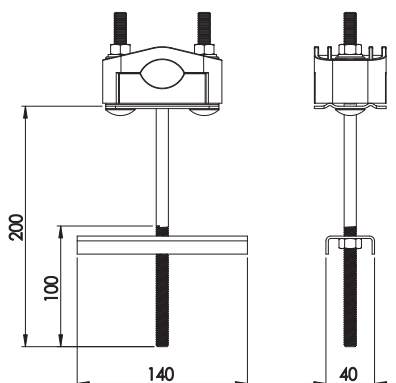

Cat. no.	Name	Bracket range Ø	Weight [kg/pc]
U25(1)ŽN-zo	Single holders U0 with offset	12-25 mm	0.58
U25(2)ŽN-zo	Double holders U0 with offset	12-25 mm	1.10
U25(3)ŽN-zo	Triple holders U0 with offset	12-25 mm	1.39
U50(1)ŽN-bo	Single holders U1 without offset	25-50 mm	0.47
U50(2)ŽN-bo	Double holders U1 without offset	25-50 mm	0.98
U50(3)ŽN-bo	Triple holders U1 without offset	25-50 mm	1.23
U50(1)ŽN-zo	Single holders U1 with offset	25-50 mm	0.70
U50(2)ŽN-zo	Double holders U1 with offset	25-50 mm	0.74
U50(3)ŽN-zo	Triple holders U1 with offset	25-50 mm	1.60
U75(1)ŽN-bo	Single holders U2 without offset	45-75 mm	0.56
U75(2)ŽN-bo	Double holders U2 without offset	45-75 mm	1.02
U75(3)ŽN-bo	Triple holders U2 without offset	45-75 mm	1.61
U75(1)ŽN-zo	Single holders U2 with offset	45-75 mm	0.82
U75(2)ŽN-zo	Double holders U2 with offset	45-75 mm	1.09
U75(3)ŽN-zo	Triple holders U2 with offset	45-75 mm	1.66

We also have the L-250 and L-330



*Pipe and cable holder for reinforced concrete poles*

UM35ŽN-bo

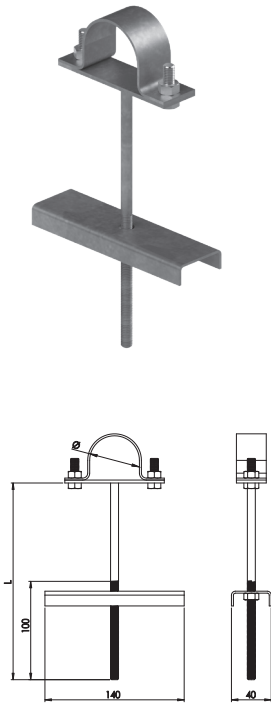
**Construction:**

- The holder are made of S235 steel.
- Hot-dip galvanized.

**Application:**

They are used to fasten cables and conduits to LV poles.

Cat. no.	Name	Weight [kg/pc]
UM25ŽN-bo	Single cable holder Ø 25	0.40
UM35ŽN-bo	Single cable holder Ø 35	0.35
UM50ŽN-bo	Single conduit holder Ø 50	0.50
UM75ŽN-bo	Single conduit holder Ø 75	0.56

*Pipe and cable holder with offset for reinforced concrete poles*

UM50ŽN-zo200

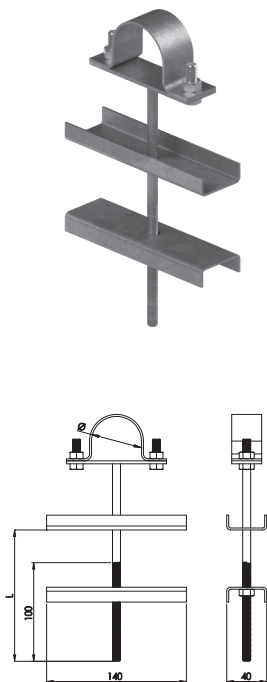
**Construction:**

- The clamps are made of S235 steel.
- Hot-dip galvanized.

**Application:**

They are used to fasten cables and conduits to LV poles.

Cat. no.	Name	Weight [kg/pc]
UM50ŽN-zo200	Single conduit holder with offset Ø 50 L200	0.62
UM50ŽN-zo250	Single conduit holder with offset Ø 50 L250	0.55
UM50ŽN-zo330	Single conduit holder with offset Ø 50 L330	0.60
UM75ŽN-zo200	Single conduit holder with offset Ø 75 L200	0.55
UM75ŽN-zo330	Single conduit holder with offset Ø 75 L330	0.61
UM110ŽN-zo200	Single conduit holder with offset Ø 110 L200	0.84
UM160ŽN-zo200	Single conduit holder with offset Ø 160 L200	0.99

Distance clamp

U104



U104T

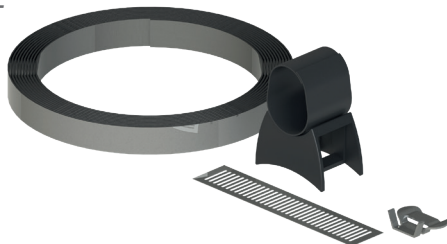

**Application:**

These clamps are used to secure a cable or wire to a pole using a steel tape. They are applied on terminal poles at the end of overhead lines. The maximum bundle diameter is 45 mm.

Cat. no.	Name	Weight [kg/pc]
U104	Spacer clamp without steel tape	0.05
U104T	Spacer clamp with 1.3mb steel tape and buckle	1.18

Pipe and cable holder for spun pole

UM25W  
UM35W  
UM40W



UM50W  
UM75W  
UM110W  
UM160W



UM110W

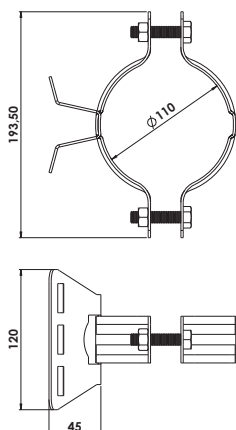

**Construction:**

- The holders are made of S235 steel.
- Hot-dip galvanized.

**Application:**

They are used to fasten cables and conduits to spun poles using steel tape.

Cat. no.	Name	Weight [kg/pc]
UM25W	Conduit clamp for spun pole Ø 25	0.15
UM35W	Conduit clamp for spun pole Ø 35	0.21
UM40W	Conduit clamp for spun pole Ø 40	0.22
UM50W	Conduit clamp for spun pole Ø 50	0.53
UM75W	Conduit clamp for spun pole Ø 75	0.58
UM80W	Conduit clamp for spun pole Ø 80	0.68
UM110W	Conduit clamp for spun pole Ø 110	0.69
UM160W	Conduit clamp for spun pole Ø 160	0.80



Single wall holders U0, U1 and U2

U50(1)P

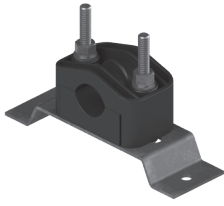

U75(1)P

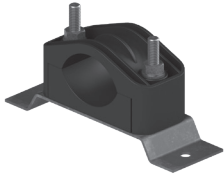

**Construction:**

Black-coloured polyamide, resistant to UV radiation and varying weather conditions, and S235 galvanized steel.

**Application:**

They are used to fasten a single wire or cable to a flat surface.

Cat. no.	Name	Bracket range Ø	Weight [kg/pc]
U25P	Single holder U0 wall-mounted	12-25 mm	0.400
U50(1)P	Single holder U1 wall-mounted	25-50 mm	0.485
U75(1)P	Single holder U2 wall-mounted	45-75 mm	0.634

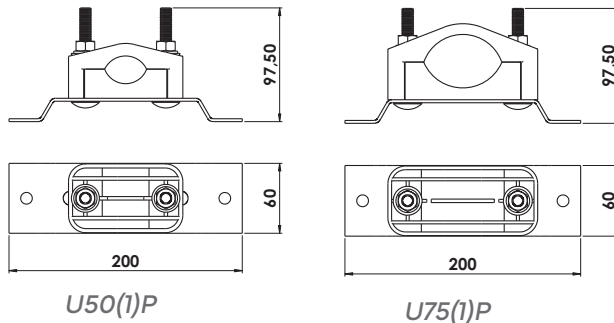

Triple and quadruple wall holder

U50(3)P

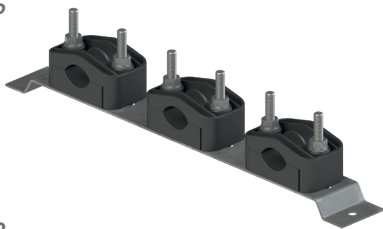

U50(4)P

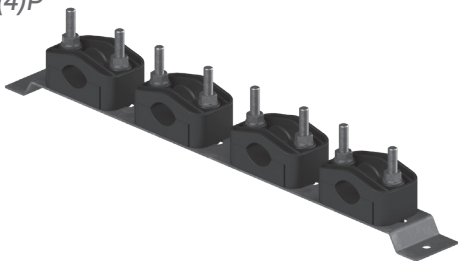

**Construction:**

Black-coloured polyamide, resistant to UV radiation and varying weather conditions, and S235 galvanized steel.

**Application:**

They are used to fasten a cable or wire on a flat surface (triple or quadruple version).

Cat. no.	Name	Bracket range Ø	Weight [kg/pc]
U50(3)P	Triple holder U1 wall-mounted	25-50 mm	1.390
U50(4)P	Quadruple holder U1 wall-mounted	25-50 mm	1.690

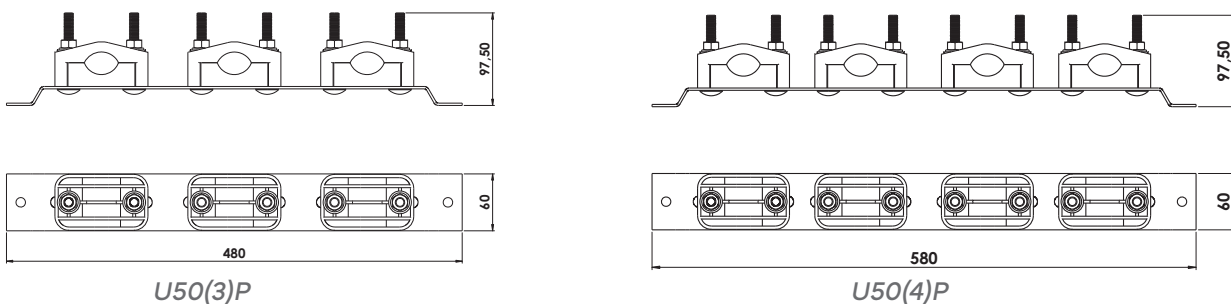

Low-voltage disconnecter mounting structure

KZRNN-01  
KZRNN-02

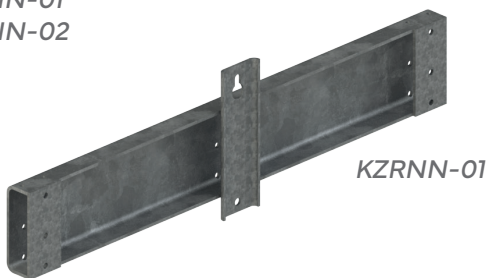

KZRNN-01



KZRNN-02

**Construction:**

- Structure made of S235 steel.
- Hot-dip galvanized.

**Application:**

Structures used for the assembly of LV disconnecters to ŻN and E-type poles. Mounted to poles using steel tape.

Cat. no.	Name	Weight kg
KZRNN-01	Structure for the attachment of low-voltage disconnectors (5x 160A or 2x 160A and 2x 400A)	8.6
KZRNN-02	Structure for the attachment of low-voltage disconnectors (1x 160A or 400A)	1.6

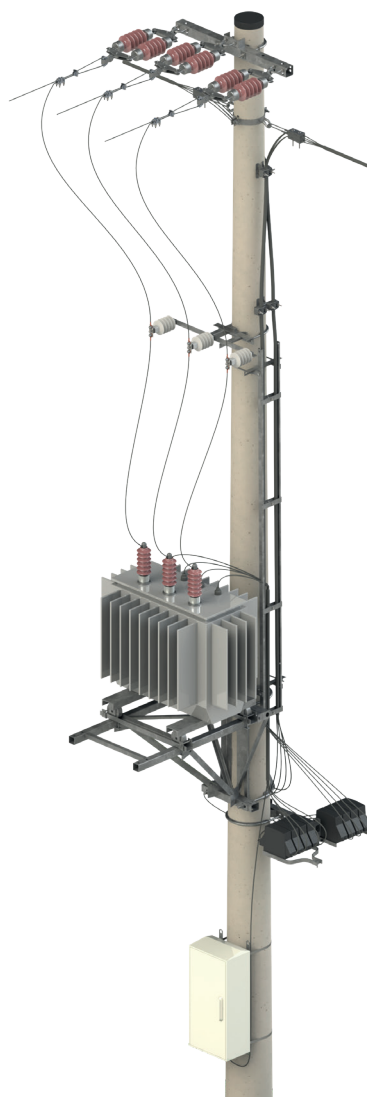
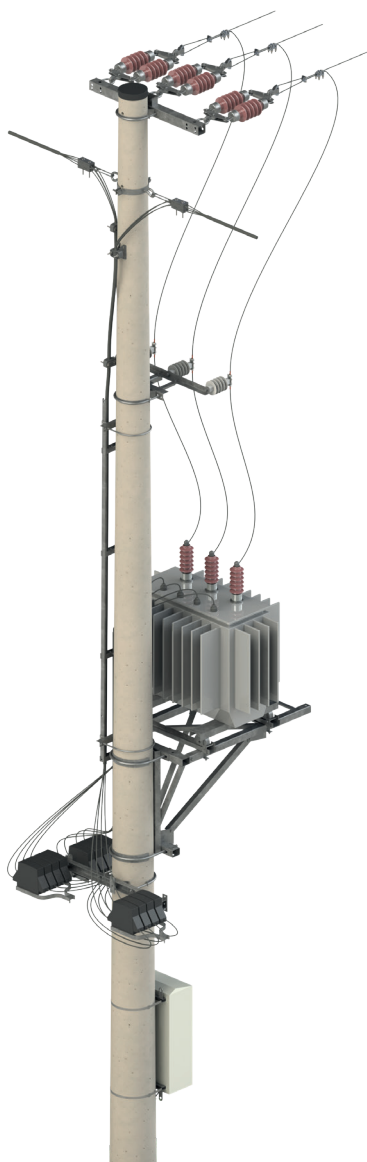

## Lamp arm

## a) single-arm bracket

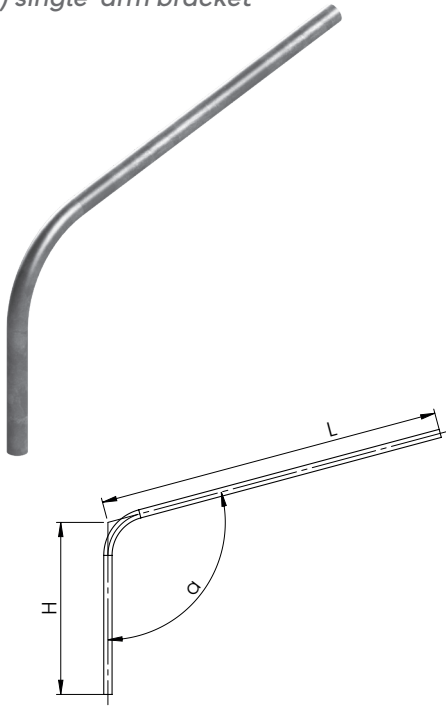
**Application:**

They are used for mounting street lighting luminaires on spun poles, medium-voltage poles (ŽN / BSW), and flat surfaces such as building walls.

Cat. no. H x L	Name	Weight [kg/pc]
W0.5X0.5	Bracket 500x500 angle $\alpha$ , conduit 48.3/2.9 mm (1.5")	3.3
W0.5X1.0	Bracket 500x1000 angle $\alpha$ , conduit 48.3/2.9 mm (1.5")	5.0
W0.5X1.5	Bracket 500x1500 angle $\alpha$ , conduit 48.3/2.9 mm (1.5")	6.6
W0.5X2.0	Bracket 500x2000 angle $\alpha$ , conduit 48.3/2.9 mm (1.5")	8.0
W0.5X2.5	Bracket 500x2500 angle $\alpha$ , conduit 48.3/2.9 mm (1.5")	9.8
W1X0.5	Bracket 1000x500 angle $\alpha$ , conduit 48.3/2.9 mm (1.5")	5.0
W1X1.0	Bracket 1000x1000 angle $\alpha$ , conduit 48.3/2.9 mm (1.5")	7.0
W1X1.5	Bracket 1000x1500 angle $\alpha$ , conduit 48.3/2.9 mm (1.5")	8.7
W1X2.0	Bracket 1000x2000 angle $\alpha$ , conduit 48.3/2.9 mm (1.5")	10.2
W1X2.5	Bracket 1000x2500 angle $\alpha$ , conduit 48.3/3.2 mm (1.5")	11.9

On request, we can also manufacture 1, 2, 3 and 4 arm brackets with different dimensions and opening angles.

## b) double-arm bracket



Double-arm bracket parameters according to individual specifications:

H – bracket height.

L - arm length

$\alpha$  - bracket angle

$\beta$  - angle between the arms

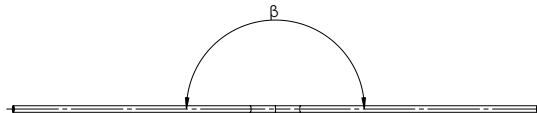
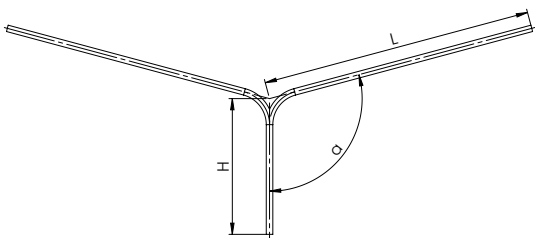

c) triple-arm bracket

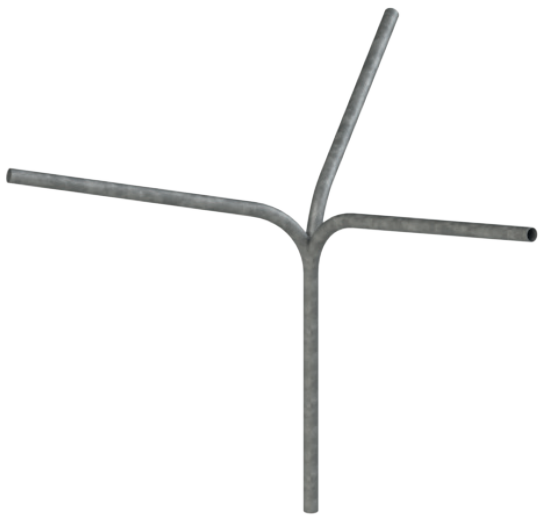

Triple-arm bracket parameters according to individual specifications:

H - bracket height

L - arm length

$\alpha$  - bracket angle

$\beta_1$  - angle between the arms 1-2

$\beta_2$  - angle between the arms 2-3

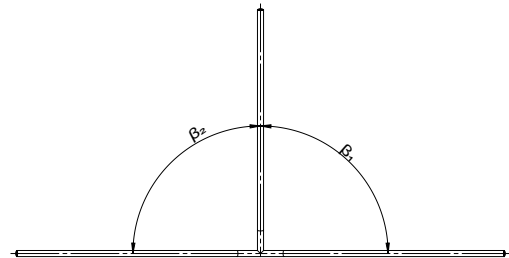
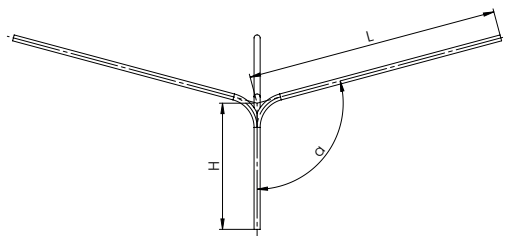

d) four-arm bracket



Four-arm bracket parameters according to individual specifications:

H - bracket height

L - arm length

$\alpha$  - bracket angle

$\beta_1$  - angle between the arms 1-2

$\beta_2$  - angle between the arms 2-3

$\beta_3$  - angle between the arms 3-4

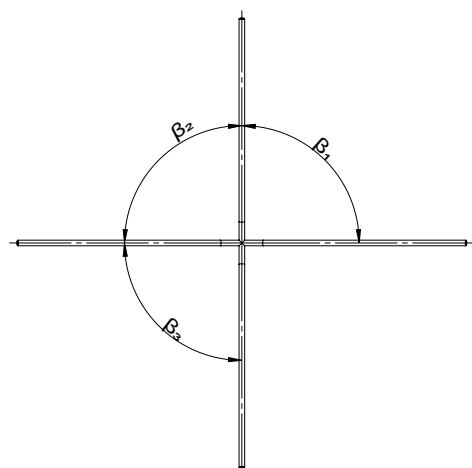
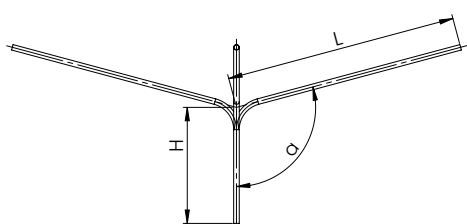

### Side-mounted lighting arm for spun poles

Wo-1  
Wo-2



#### Application:

The Wo-1 (for top diameter = 173) and Wo-2 (for top diameter = 218) brackets are designed for mounting street lighting luminaires on the side of E-type spun poles, below overhead power lines.

- Wo-4 bracket for poles with a diameter of  $\varnothing$  173 mm
- Standard size: 0.5 x 1 m
- Other available sizes: 0.5 x 1.5 m, 0.5 x 2 m, and custom dimensions upon request.
- Mounted using two 03/A steel clamps.
- Wo-1 bracket for poles with a diameter of  $\varnothing$  218 mm
- Standard size: 0.5 x 1m
- Other available sizes: 0.5 x 1.5 m, 0.5 x 2 m, and custom dimensions upon request.
- Mounted using two 03/A steel clamps.

We also offer brackets for poles with a top diameter of  $\varnothing$  263 mm (model Wo-2/263), mounted using 04/A clamps.

### Top-mounted brackets for luminaires on the apex of spun poles

Wo-4  
Wo-5  
Wo-5/263



#### Application:

Wo-4 brackets (for top diameter = 173) and Wo-5 brackets (for top diameter = 218) are used for mounting street lighting luminaires on the apex of spun poles of type E, above the cables.

- Wo-4 bracket for poles with a diameter of  $\varnothing$  173 mm
- Standard size: 0.5 x 1 m
- Other available sizes: 0.5 x 1.5 m, 0.5 x 2 m, and custom dimensions upon request.
- Wo-1 bracket for poles with a diameter of  $\varnothing$  218 mm
- Standard size: 0.5 x 1m
- Other available sizes: 0.5 x 1.5 m, 0.5 x 2 m, and custom dimensions upon request.

We also manufacture brackets for poles with larger top diameters, e.g. 263 mm (Wo-5/263)

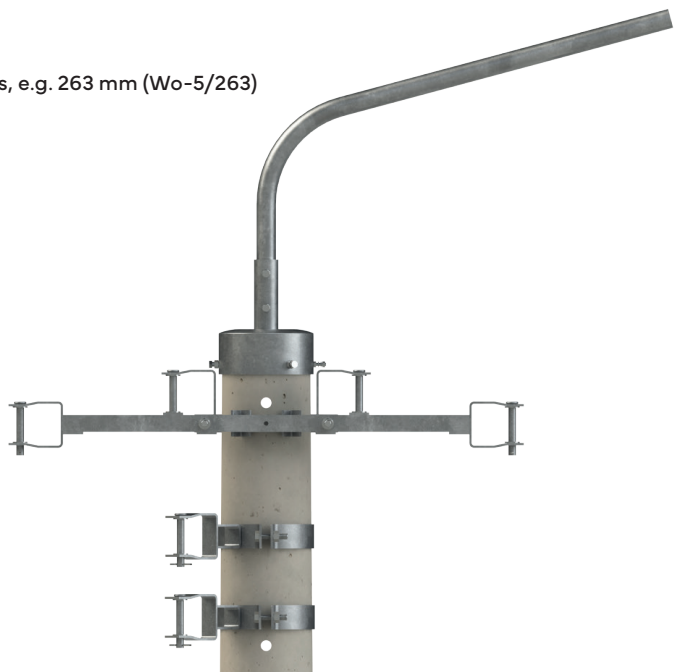

Spun pole arm holder attached under the line (with a steel strap)

W1051

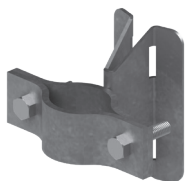

UWEPV/1,5

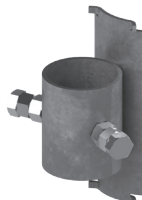

UWEPV/2/1,5



**Construction:**

- The clamps are made of S235 steel.
- Hot-dip galvanized.

**Application:**

They are used for mounting street lighting brackets on spun poles using a stainless-steel tape. The manufacturer recommends using tape-mounted brackets for luminaires with an outreach of up to 1.5 meters.

Cat. no.	Name	Weight [kg/pc]
W1051	Tape-mounted bracket clamp for spun pole	0.92
UWEPV/1.5	Tape-mounted bracket clamp for EPV pole Ø 48 mm (1.5")	0.7
UWEPV/2	Tape-mounted bracket clamp for EPV pole Ø 60.3 mm (2")	0.8
UWEPV/2/1.5	Double tape-mounted bracket clamp for EPV pole Ø 48 mm (1.5")	1.4
UWEPV/2/2	Double tape-mounted bracket clamp for EPV pole Ø 60.3 mm (2")	1.6



Spun pole arm holder attached under the line

W1052



**Construction:**

- The holders are made of S235 steel.
- Hot-dip galvanized.

**Application:**

They are used for mounting street lighting brackets on spun poles. Most commonly used for mounting long or multi-arm brackets.

Cat. no.	Name	Ø of the clamp (od-do)	Weight [kg/pc]
W1054	Spun pole arm holder (stirrup bolt)	150 mm requires clamp 01	1.78
W1052	Spun pole arm holder (stirrup bolt)	155-190 mm requires clamp 01A	1.80
W105	Spun pole arm holder (stirrup bolt)	200-240 mm requires clamp 03A	2.00
W1053	Spun pole arm holder (stirrup bolt)	263 mm requires clamp 04A	2.20

Require clamps:

O1/A for type E with top diameter = 173

O3/A for type E with top diameter = 218

O4/A for type E with top diameter = 263

## Wall arm holder

W10  
W10/150

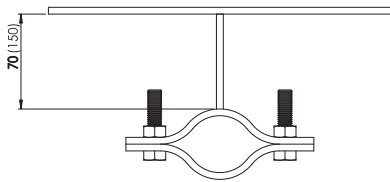
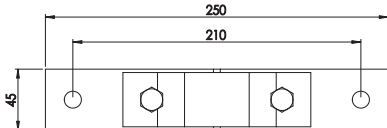
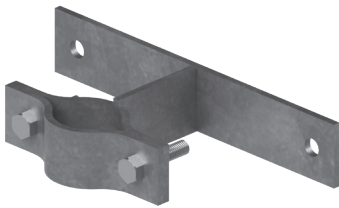

### Construction:

- The holder are made of S235 steel.
- Hot-dip galvanized or electro-galvanized.

### Application:

They are used for mounting street lighting brackets and poles on building walls or other flat surfaces using expansion bolts. Spacer lengths in the brackets range between 70 mm and 1000 mm.

Cat. no.	Name	Weight [kg/pc]
W10	Wall arm holder	1.14
W10/150	Wall arm holder	1.55

## Bracket holder L-200...L-1000

W10/200-1000

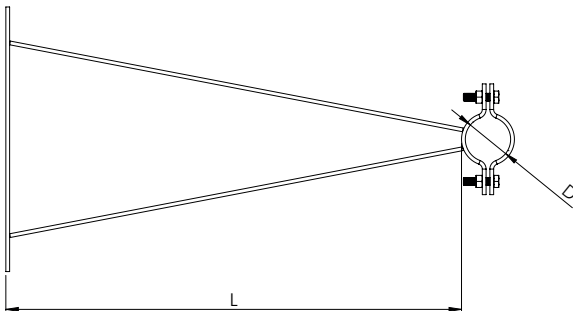
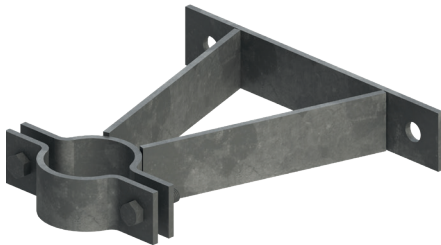

### Construction:

- All holders are made of St3s steel.
- Hot-dip galvanized.

### Application:

Used for mounting 1.5" diameter brackets to street lighting luminaires, poles on building walls, and other flat surfaces using expansion bolts.

Cat. no.	Name	Basis D	Weight [kg/pc]
W10/200	Wall-mounted bracket holder L-200	D-250	1.75
W10/250	Wall-mounted bracket holder L-250	D-250	2.20
W10/300	Wall-mounted bracket holder L-300	D-250	2.40
W10/350	Wall-mounted bracket holder L-350	D-250	2.45
W10/400	Wall-mounted bracket holder L-400	D-350	3.00
W10/500	Wall-mounted bracket holder L-500	D-350	3.10
W10/600	Wall-mounted bracket holder L-600	D-350	4.20
W10/700	Wall-mounted bracket holder L-700	D-350	4.60
W10/800	Wall-mounted bracket clamp L-800	D-550	5.00
W10/900	Wall-mounted bracket clamp L-900	D-550	5.40
W10/1000	Wall-mounted bracket clamp L-1000	D-550	5.90

**Pole arm holder**

W101C

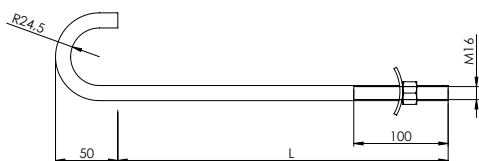

**Construction:**

- All holders are made of St3s steel.
- Hot-dip galvanized.

**Application:**

Used for mounting street lighting brackets on the side of low-voltage concrete poles.

Cat. no.	Name	Total bolt length L (mm)	Weight [kg/pc]
W108C	Pole bracket clamp L-160	210	0.50
W101C	Pole bracket clamp L-200	250	0.60
W102C	Pole bracket clamp L-250	350	0.66
W109C	Pole bracket clamp L-300	350	0.75

**Insulated arm holder**

W103

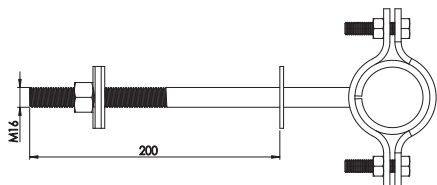
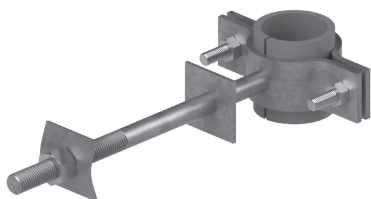

**Construction:**

- They are made of S235 steel.
- Hot-dip galvanized.

**Application:**

Used for mounting street lighting brackets on the side of low-voltage concrete poles, building walls, and similar surfaces. The brackets feature an offset that allows work using pole climbers. A Teflon insert insulates the bracket from the pole, eliminating the need for additional earthing of the bracket.

Cat. no.	Name	Weight [kg/pc]
W103	Insulated bracket clamp	1.38



Pole bracket holder

W104



**Construction:**

- All holders are made of S235 steel.
- Hot-dip galvanized.

**Application:**

Used for mounting street lighting brackets on the apex of low-voltage concrete poles.

Cat. no.	Name	Pole width
W104	Reinforced concrete pole top arm holder	150 mm
W104W	Reinforced concrete pole top arm holder	100 mm
W1041	Reinforced concrete A - pole top arm holder	Wedge mounting
W1042	Reinforced concrete A - pole top arm holder	200 mm - 300 mm

W104W

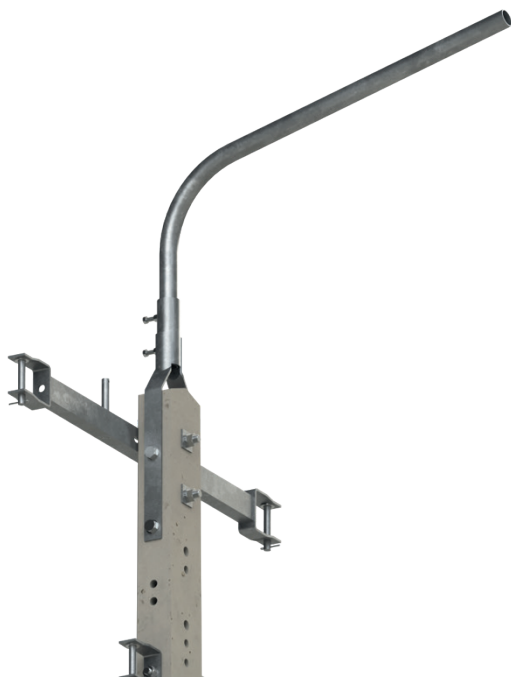

Spun pole top arm holder

W106

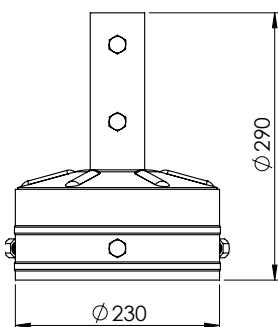

**Construction:**

- They are made of S235 steel.
- Hot-dip galvanized.

**Application:**

Used for mounting street lighting brackets on the apex of spun poles. Recommended for single- and double-arm brackets with dimensions from 0.5 × 0.5 m to 0.5 × 1.0 m.

Cat. no.	Name	Ø top diameter of poles	Ø of bracket	Weight [kg/pc]
W1061	Bracket clamp for spun pole	173 mm	1,5"	3.20
W106	Bracket clamp for spun pole	218 mm	1,5"	4.10
W1069	Bracket clamp for spun pole	240 mm	1,5"	4.50
W1067	Bracket clamp for spun pole	263 mm	1,5"	4.70
W1062	Bracket clamp for spun pole	173 mm	2"	3.20
W1066	Bracket clamp for spun pole	218 mm	2"	4.50
W1068	Bracket clamp for spun pole	263 mm	2"	4.60

Reinforced Spun pole top arm holder

W106/W

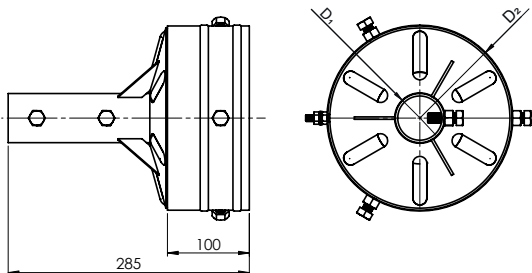

**Construction:**

- The clamps are made of S235 steel.
- Hot-dip galvanized.

**Application:**

Used for mounting street lighting brackets on the apex of spun poles.

Cat. no.	Name	Ø top diameter of poles	Ø of bracket	Weight [kg/pc]
W1061/W	Reinforced bracket clamp for spun pole	173	1,5"	3.20
W106/W	Reinforced bracket clamp for spun pole	218	1,5"	4.10
W1069/W	Reinforced bracket clamp for spun pole	240	1,5"	4.50
W1067/W	Reinforced bracket clamp for spun pole	263	1,5"	4.70
W1062/W	Reinforced bracket clamp for spun pole	173	2"	3.20
W1066/W	Reinforced bracket clamp for spun pole	218	2"	4.50
W1068/W	Reinforced bracket clamp for spun pole	263	2"	4.60

## Overhead fuse BN25A / BN63A

Z 207

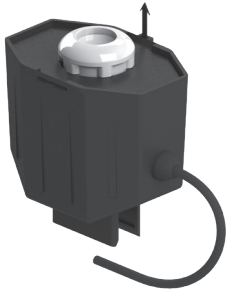

Z207 + Z2082Z (for ASxSN)  
Z207 + Z208Z (for AL)

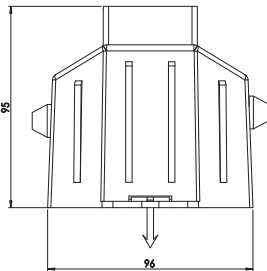
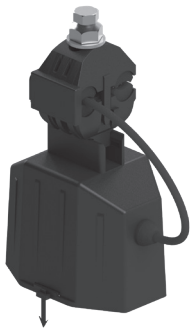

Z 207

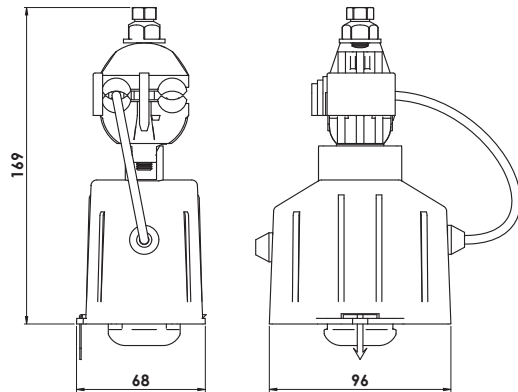
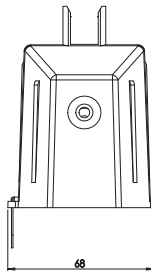

Z207 + Z2082Z

**Construction:**

- The fuse cover is made of plastic.
- The 25 A or 63 A fuse socket is made of electrical-grade porcelain with external surfaces glazed in white.
- The upper and lower contacts are made of brass and equipped with main clamps.
- The metal components of the socket are protected against corrosion with protective coatings.

**Application:**

Used for protecting street lighting circuits or small electrical loads. Designed to be mounted on insulation-piercing connectors, either of our own production or those supplied by other manufacturers. Suitable for installation on bundles of insulated AsXS(n) conductors or bare aluminium (AL) cables.

**Technical data:**

Rated voltage	500V
Rated current	25A or 63A
Upper contact thread	E27 or E33
Cable connectivity	at BN-25A from 1.5 mm to 10 mm; at BN-63A from 2.5 mm to 25 mm

Nr katalogowy	Type	Rated voltage	Max. fuse	Pack pcs.	Cable Connectivity	Weight [kg/pc]
Z207	BN25 A	500V	25 A	30	1,5 mm-10 mm	0.21
Z2071	BN63 A	500V	63 A	30	2,5 mm-25 mm	0.33
Z207 + Z2082Z (for ASxSN) Z207 + Z208Z (for AL)	BN25 A + CLAMP	500V	25 A	30	1,5 mm-10 mm	0.32
Z2071+Z2082Z (for ASxSN) Z208Z Z2071 + Z208Z (for AL)	BN63 A + CLAMP	500V	63 A	30	2,5 mm-25 mm	0.42

**Overhead fuse BNA 25 LN 25-70 mm<sup>2</sup>**  
**Uninsulated line BNA 25 LI 16-35 mm<sup>2</sup>**  
**Insulated line**

BNA 25 LI

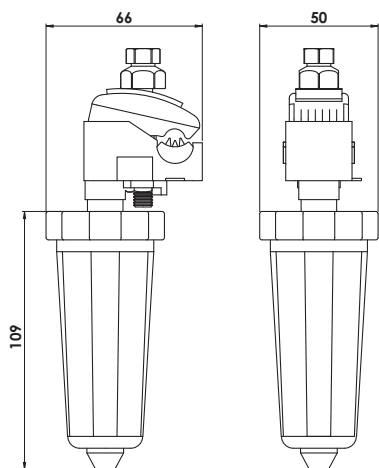

**Construction:**

- Fuse cover made of plastic.
- The 25 A fuse socket is made of electrical-grade porcelain with external surfaces glazed in white.
- Equipped with a shear nut.

**Application:**

Used for protecting street lighting circuits or small electrical loads. Designed for installation on bundles of bare aluminium (AL) cables (BNA 2) or insulated AsXS(n) cables (BNA 1).

Cat. no.	Type	Rated voltage	Max. fuse	Pack pcs.	Cable Connectivity	Weight [kg/pc]
BNA 25 LI	BNA 1 LI	230V	25 A	30.	2.5 – 4 mm <sup>2</sup>	0.25
BNA 25 LN	BNA 2 LN	230V	25 A	30	2.5 – 4 mm <sup>2</sup>	0.25



**The fuses are compatible with most insulation-piercing connectors from competing manufacturers.**

## Insulation cable-to-pole connectors

ZKS

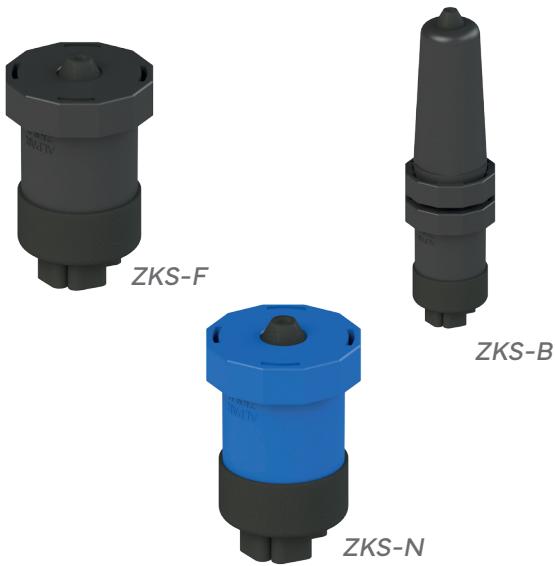

### Construction:

The housing is made of black-coloured plastic, resistant to weather conditions. Strength requirements are confirmed by tests according to PN-EN 50483:2009. The clamp is made of aluminium alloy – enabling connection of two or four AL/CU cables of 35 mm<sup>2</sup>. The screws are made of stainless steel.

### Application:

Cable connectors are used to join phase or neutral cables. They are installed in lighting pole boxes or illuminated traffic signs to connect light sources (lighting fixtures or traffic signs) to the cable line.

Cat. no.	Name	Weight [kg/pc]
ZKS-F	ZKS-F cable pole insulation connector (phase)	0.1970
ZKS-N	ZKS-N cable pole insulation connector (neutral)	0.1970
ZKS-B	ZKS-B cable pole insulation connector (fuse type)	0.1970

## Spool, pin and cap insulator

S80/2 N80/2 cap80  
S115/2 N115/2 cap115

### Application:

Low-voltage pin insulators are mounted on THS hook rods or TKS shackles. The rod is wrapped with hemp tow impregnated with red lead, then the insulator is screwed onto it or an appropriately sized cap is used. Low-voltage spool insulators are secured using clamps equipped with a pin that passes through the insulator and is fastened with a cotter pin.

We also offer spool insulators of type S-115/2 and cap insulators of type N-95.



## Hook rods

K20

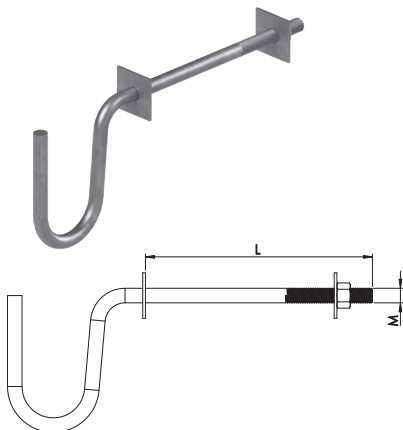

### Application:

Hook rods are used to mount pin insulators on support structures in power lines with a rated voltage up to 1 kV.

Cat. no.	Name	M	Weight [kg/pc]
K204	Hook rods THS-80 L150	16	0.76
K201	Hook rods THS-80 L200	16	0.86
K205	Hook rods THS-80 L220	16	0.90
K20	Hook rods THS-80 L250	16	0.95
K202	Hook rods THS-80 L300	16	1.00
K203	Hook rods THS-95 L220	20	1.48
K206	Hook rods THS-95 L200	20	1.40

**Straight-through, end, and corner crossarms**

PN-1

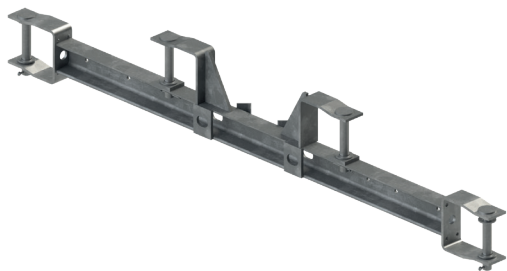

PK-1

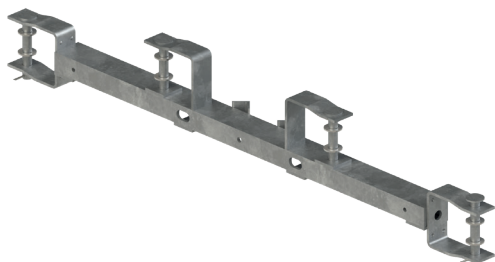

PP-3



Cat. no.	Name	U-shaped rod.	Weight [kg/pc]
PN-1 PN-2	Corner crossarm for a single pole with a bend angle of 120°-180°	TK/C-80 TK/C-115	14.6 17.8
PN-3 PN-4	Corner crossarm for a single pole with a bend angle of 90°-120°	TK/C-80 TK/C-115	16.1 21.8
PNb-1 PNb-2	Corner crossarm for a twin pole with a bend angle of 90°-180°	TK/C-80 TK/C-115	18.2 23.9
PNp-1 PNp-2	Corner crossarm for a double pole with a bend angle of 90°-180°	TK/C-80 TK/C-115	19.1 25.1
PK-1 PK-2	End crossarm for single, twin, and double poles	TK/C-80 TK/C-115	14.6 20.4
PKb-1 PKp-1 PKb-2 PKp-2	End crossarm for twin and double poles	TK/C-80 TK/C-115	14.7 17.9
PP-1	Through crossarm with O1 clamp	Insulator N80	4.25
PP-2	Through crossarm with O1 clamp	Insulator N95	4.75
PP-3	Through crossarm with O3 clamp	Insulator N80	4.50
PP-4	Through crossarm with O3 clamp	Insulator N95	4.70

**Pass-through design**

Kp-1

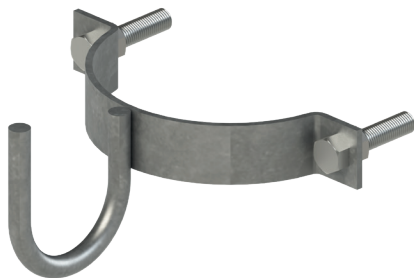

**Application:**

Structure designed for suspending bare cables on spun poles in a through (inline) configuration.

Cat. no.	Name	Diameter	Weight [kg/pc]
Kp-1 N-80	Through structure for O-1 clamp	173	1.50
Kp-2 N-95	Through structure for O-1 clamp	173	1.70
Kp-3 N-80	Through structure for O-3 clamp	240	1.75
Kp-4 N-95	Through structure for O-3 clamp	240	1.95

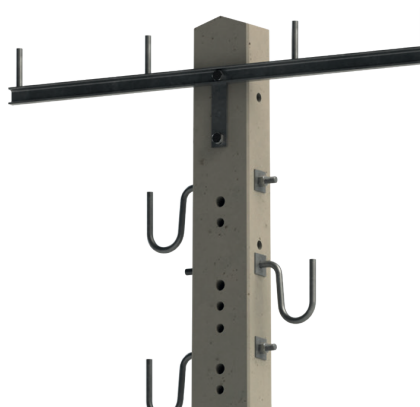

### Spun pole holders stirrup bolt

O-3



**Application:**

Clamps are used for mounting spun pole brackets, heavy-duty structures, or crossarms. Hot-dip galvanized.

Cat. no.	Name	Ø of the clamp (od-do)	Weight [kg/pc]
O1/A	Spun pole holders stirrup bolt	155-190 mm	0.69
O3/A	Spun pole holders stirrup bolt	200-240 mm	0.98
O-3	Tension structures stirrup bolt	200-240 mm	1.1
O4/A	Spun pole holders stirrup bolt	263 mm	1.18

### Tension structure

KM-1  
KM-2

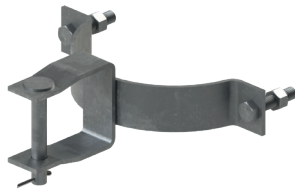

KM-3  
KM-4



KM-5  
KM-6

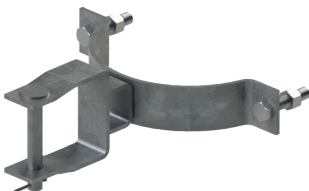

KM-7  
KM-8



KM-9  
KM-10

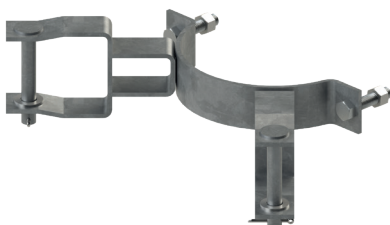

**Application:**

Heavy-duty structures (KM) are used for mounting S-80 and S-115 type insulators on spun poles.

Cat. no.	Name	Ø of the clamp	Insulator	Weight [kg/pc]
KM-1/173	Tension structure	173 mm requires O1/A clamp	TK/C-80	2.15
KM-2/173	Tension structure		TK/C-115	3.00
KM-3/173	Tension structure		TK/C-80	2.62
KM-4/173	Tension structure		TK/C-115	3.47
KM-5/173	Tension structure		TK/C-80	3.47
KM-6/173	Tension structure		TK/C-115	4.12
KM-7/173	Tension structure		TK/C-80	2.90
KM-8/173	Tension structure		TK/C-115	4.00
KM-9/173	Tension structure		2xTK/C-80	4.80
KM-10/173	Tension structure		2xTK/C-115	6.05
KM-1	Tension structure	200-240 mm requires O-3 clamp (KM)	TK/C-80	2.80
KM-2	Tension structure		TK/C-115	3.58
KM-3	Tension structure		TK/C-80	2.80
KM-4	Tension structure		TK/C-115	3.60
KM-5	Tension structure		TK/C-80	3.25
KM-6	Tension structure		TK/C-115	4.12
KM-7	Tension structure		TK/C-80	3.30
KM-8	Tension structure		TK/C-115	4.20
KM-9	Tension structure		2xTK/C-80	4.90
KM-10	Tension structure		2xTK/C-115	6.71
KM-1/263	Tension structure	263 mm requires O4/A clamp	TK/C-80	2.68
KM-2/263	Tension structure		TK/C-115	3.56
KM-3/263	Tension structure		TK/C-80	2.80
KM-4/263	Tension structure		TK/C-115	3.47
KM-5/263	Tension structure		TK/C-80	3.40
KM-6/263	Tension structure		TK/C-115	3.90
KM-7/263	Tension structure		TK/C-80	3.10
KM-8/263	Tension structure		TK/C-115	4.10
KM-9/263	Tension structure		2xTK/C-80	4.80
KM-10/263	Tension structure		2xTK/C-115	6.60

Shackle – TKS 1 frame

TKTs1/80



**Application:**

U-bolt rods are intended for mounting porcelain spool insulators on support structures in overhead lines up to 1 kV, using a steel tape.

Cat. no.	Name	Weight [kg/pc]
TKTs1/80	TKTs1/80 shackle-type frame for steel tape mounting	1.39
TKTs1/115	TKTs1/115 shackle-type frame for steel tape mounting	2.40

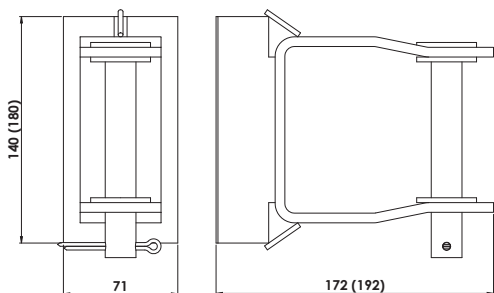

Shackle - TKS frame

K30

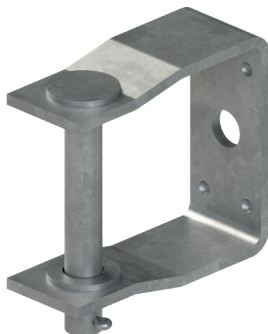

**Application:**

U-bolt rods are intended for mounting porcelain spool insulators significantly on support structures in overhead lines up to 1 kV.

Cat. no.	Name	Weight [kg/pc]
K30	TKS S-80 shackle frame	1.10
K301	TKS S-115 shackle frame	2.00

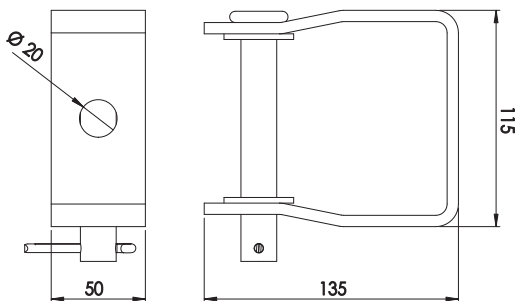

## Structure for a stork nest

GB

**Application:**

The structure is designed to create dedicated nests for storks. It allows installation not only on E-type and ŽN-type power poles, but also – after minor structural modifications – on poles erected specifically for storks.

GB-1

**GB-1 Stork nest**

The mounting elements for the E/ŽN/BSW-type pole are supplied as a complete set with the nest structure (the type of fastening must be specified when placing the order).

**Construction:**

- S235JR steel sections.
- Hot-dip galvanized structure.

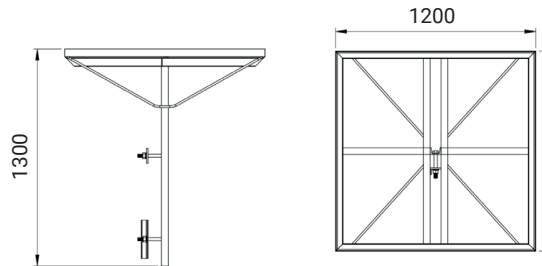

GB-2

**GB-2 Stork nest (detachable)**

The mounting elements for the E/ŽN/BSW-type pole are supplied as a complete set with the nest structure (the type of fastening must be specified when placing the order).

**Construction:**

- S235JR steel sections.
- Hot-dip galvanized structure.

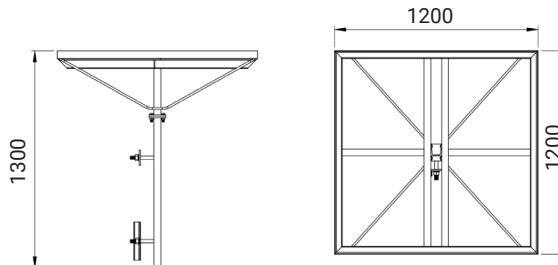

GB-3

**GB-3 Stork nest (detachable)**

The mounting elements for the E/ŽN/BSW-type pole are supplied as a complete set with the nest structure (the type of fastening must be specified when placing the order).

**Construction:**

- S235JR steel sections.
- Hot-dip galvanized structure.
- Equipped with a perforated platform.

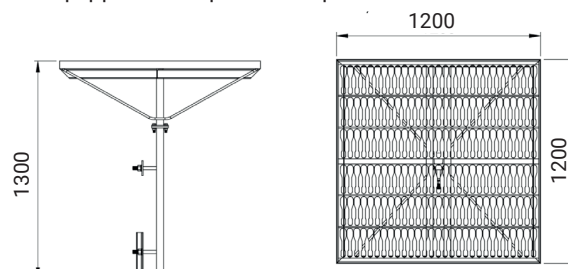

GB-6



**GB-6 Stork nest (disassembled)**

The mounting elements for the E/ŽN/BSW-type pole are supplied as a complete set with the nest structure (the type of fastening must be specified when placing the order).

**Construction:**

- S235JR steel sections.
- Hot-dip galvanized structure.

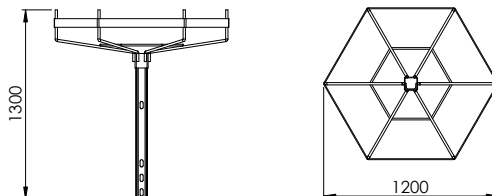

GB-8



**GB-8 Stork Nest**

Mounting elements for the type E pole are supplied as a complete set with the nest structure. Apex mounting for spun pole type E with a top diameter of 173/218/240/263/308 mm (to be specified when placing the order).

**Construction:**

- S235JR steel sections.
- Hot-dip galvanized construction.

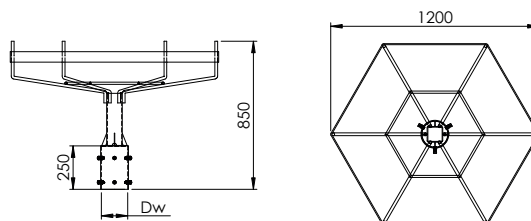

## Single-clevis extension link

3837

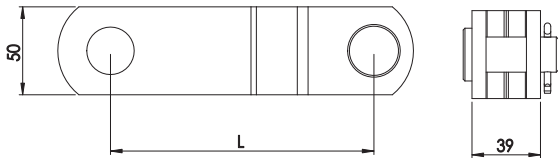

38352

**Application:**

They are used to adjust the length of the cable suspension.

Cat. no.	Name	Breaking load kN	Weight [kg/pc]
3837	Single-clevis extension connector L-150	120	1.32
38352	Single-clevis extension connector L-200	120	1.72
3842	Single-clevis extension connector L-300	120	2.3
38421	Single-clevis extension connector L-320	120	2.42
38430	Single-clevis extension connector L-400	120	2.95
38431	Single-clevis extension connector L-450	120	3.32
38450	Single-clevis extension connector L-600	120	4.27
38451	Single-clevis extension connector L-700	120	4.9
3851	Single-clevis extension connector L-850	120	5.9
38513	Single-clevis extension connector L-1000	120	6.96

## Top wedge KSW

K10

**Application:**

- They are used to connect spreader ŽN poles together. Most commonly used at line ends, angles, or as termination points of power lines.
- Hot-dip galvanized.

Cat. no.	Name	Weight [kg/pc]
K10	Top wedge	24.6

## Reinforced concrete pole Stretcher bar

K101

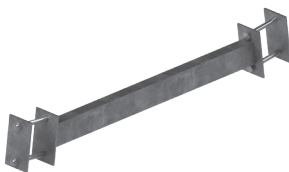
**Application::**

- They are used to connect ŽN poles together. Most commonly used at line ends, angles, or as termination points of power lines.
- Hot-dip galvanized.

Cat. no.	Name	Weight [kg/pc]
K101	Reinforced concrete pole stretcher bar	18,2

**Bolt screw clamp**

2421

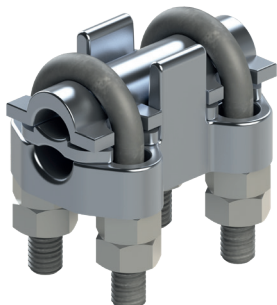

**Application:**

Bolt-and-U-bolt clamps are used for connecting two aluminium or steel-aluminium cables, for closing loops on post insulators, and for use with U-bolt end clamps (half-sheaves).

Cat. no.	Name	Min. slip-out force kN	Weight [kg/pc]
2411	Bow screw clamp 8-10 (35-50)	5	0.27
2421	Bow screw clamp 11-15 (70-120)	7	0.51
2431	Bow screw clamp 15-19 (150-185)	14	0.79

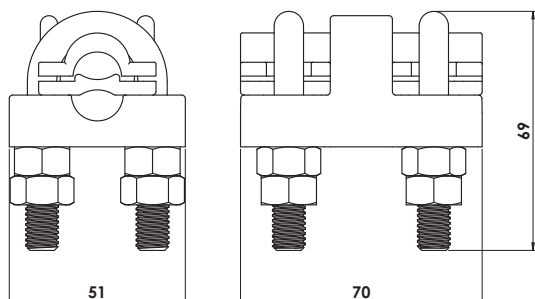

**Bolt screw hanger**

41111



**Application:**

U-bolt hangers are used for suspension of insulator strings – either in straight-through or strain configurations – on supporting structures.

Cat. no.	Height H	Length H	Thread length l	Breaking load kN	Weight [kg]
41111	90	140	80	100	0.72
41121	90	200	140	100	0.80
41122	50	200	140	100	0.90

41121



41122

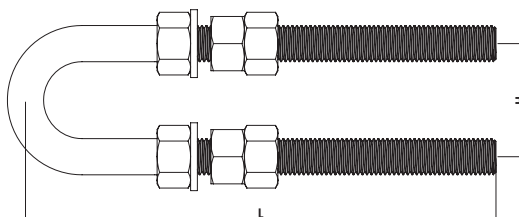

**Anchor bow holder**

23255

**Application:**

U-bolt end holder are used for strain suspension of aluminium or steel-aluminium cables on suspension insulators.

Cat. no.	For conductors with a diameter of mm	Breaking load kN	Weight [kg]
23255	6-12	40	0.46

**Double-eye link**

3532

**Application:**

Used for connecting various accessories into chains.

Cat. no.	Name	Breaking load kN	Weight [kg]
3532	Twisted double-eye connector	120	0.60
3521	Flat double-eye connector	300	0.80

3521

**V-type strain yoke**

38253

38254

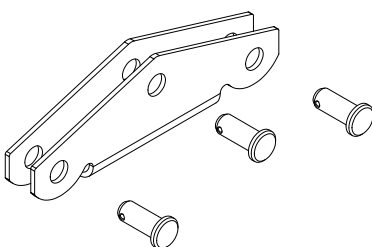
**Application:**

The double-row yoke connector is designed for connecting suspension insulators into double-string chains for overhead lines.

Cat. no.	Name	Breaking load kN	Weight [kg]
38253	L200 double-row yoke connector	160	1.10
38254	L250 double-row yoke connector	160	1.60

**Aluminium feeder clamps**

Z 3011

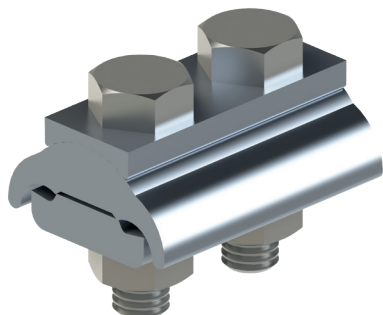

**Application:**

They are used for connecting bare aluminium cables in overhead power lines.

Cat. no.	Name	Weight [kg/pc]
Z301	Al. current clamp 6-35	0.07
Z3011	Al. current clamp 10-50	0.08
Z3012	Al. current clamp 16-95	0.17
Z3013	Al. current clamp 16-150	0.22

**AL-CU feeder clamps**

Z 302

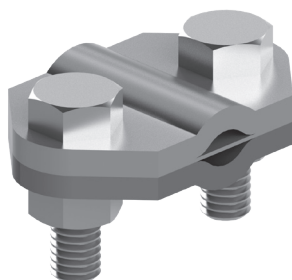

**Application:**

They are used to connect bare aluminium cables to copper cables.

Cat. no.	Name	Weight [kg/pc]
Z302	Feeder clamp Al-Cu 6-35	0.05
Z3021	Feeder clamp Al-Cu 10-50	0.11

**Loop clamps**

Z3031

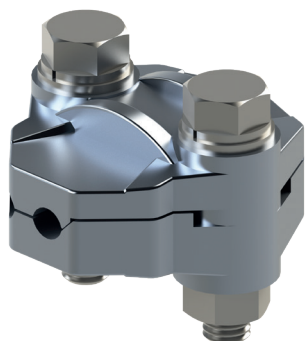

**Application:**

They are used in strain suspensions of bare aluminium and steel-aluminium cables, with the possibility of branching off with an aluminium cable.

Cat. no.	Name	Weight [kg/pc]
Z303	Loop clamp 10-16	0.06
Z3031	Loop clamp 25-35	0.13
Z3032	Loop clamp 50-70	0.30

## Power lock

K62

**Construction:**

- Power lock with a triangular key, shackle thickness 8 mm.
- 8 mm triangular key.

**Application:**

The energy lock is suitable for securing cable joints, gas connections, water intakes, antenna cabinets, meter cabinets, control cabinets, and similar applications.

Cat. no.	Name	Weight [kg/pc]
K62	Power lock	0.17
K621	Energy lock/cable connector key	0.013

## Rod cover

K61

**Construction:**

- Made of UV-resistant plastic.

**Application:**

It protects against water ingress and is mounted on the rods of connections (1.5- and 2-inch conduits) that lead cables into the building.

## Stand-off insulator

K60

**Application:**

Indoor supporting insulator, used to insulate busbars in distribution installations with voltages up to 1 kV and mains frequency up to 100 Hz.

**Installation:**

The fixing screws should be screwed in 14 mm deep. Recommended tightening torque of 10 Nm.

Steel strap / buckle

T207 K207



Application:

The steel tape with buckles is used for the permanent installation of pole accessories. It is made of stainless steel and its edges are blunt. The tape is packaged in plastic housings or cardboard enclosures that allow specific sections of tape to be easily cut off.

Cat. no.	Name	Notes	Weight [kg]
T207	Steel strap	20x0.7 in 50mb or 25mb rolls	0.115 kg/m
K207	Buckle	Pack of 100	0.015 [kg/pc]
T207/10	Steel strap	10x0.7 in 50mb or 25mb rolls	0.008 kg/m
K207/10	Buckle	Pack of 100	0.008 [kg/pc]

Flexible cap

OE1  
OE2  
OE3  
OE4



Application:

Insulating sheath to protect cable ends. The tips are made of rubber and are assembled by pressing it onto the end of the cable.

Cat. no.	Name	Diameter mm	Diameter mm <sup>2</sup>	Length	Weight [kg]
OE1	Cover cap	Ø 3-6mm	6-10 mm <sup>2</sup>	30	0.002
OE2	Cover cap	Ø 7-10 mm	16-35 mm <sup>2</sup>	34	0.003
OE3	Cover cap	Ø 9-14 mm	35-70 mm <sup>2</sup>	38	0.006
OE4	Cover cap	Ø 14-19 mm	95-150 mm <sup>2</sup>	42	0.012

Insulated connectors

MJPT 16 - 95



Application:

For connecting AsXS(n) insulated conductors of the same cross-section. Once clamped, the connectors do not require additional insulation.

Cat. no.	Cable cross section	Jaw	Connector colour	Weight [kg]
MJPT 16	16/16	E173	blue	0.03
MJPT 25	25/25	E173	orange	0.03
MJPT 35	35/35	E173	red	0.03
MJPT 50	50/50	E173	yellow	0.04
MJPT 70	70/70	E173	white	0.05
MJPT 95	95/95	E173	grey	0.06

## Steel strap tensioner

N207

**Application:**

Used for clamping and cutting steel strap. The main application is for spun poles or poles that do not have holes for standard hook bolts, etc.

Cat. no.	Name	Max force kN	Weight kg
N207	Steel strap tensioner	10	2.00

## Toggle clamp

N218  
N2181**Application:**

Used to lay overhead lines when they are mounted on poles or building walls.

Cat. no.	Name	Max cable diameter	Weight kg
N218	Toggle clamp	2/4x16-70mm <sup>2</sup>	2.3
N2181	Toggle clamp	1x16-95mm <sup>2</sup>	1.3

## Swivel

N219

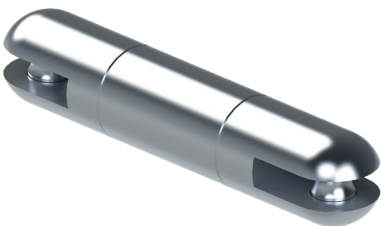
**Application:**

Used to lay overhead lines most often when unwinding cables from drums or laying them on poles to relieve cable tension.

Cat. no.	Name	Max force kN	Weight kg
N219	Swivel	10	0.5

Hybrid box wrench for clamps

N231



**Application:**

Used to hold the clamp when tightening with a dynamometric or hexagonal wrench. The grip parts of the wrenches are insulated which allows for live work.

Cat. no.	Name	Application	Weight kg
N231	Hybrid box wrench for clamps	For all clamps	0.12

Hex key (Allen key)

N221

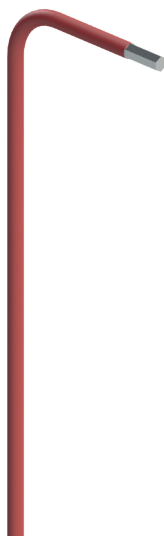

**Application:**

Used for tightening clamp screws during installation on overhead lines. The grip parts of the wrenches are insulated which allows for live work.

Cat. no.	Name	Size mm	Weight kg
N221	Hex key (Allen key)	6	0.09

Separating wedges

N228

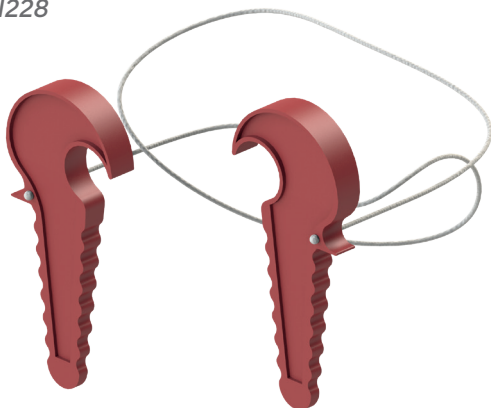

**Application:**

They are used to separate a bundle of cables for installing a clamp or end bracket.

Cat. no.	Name	Weight kg
N228	Separating wedges	0.11







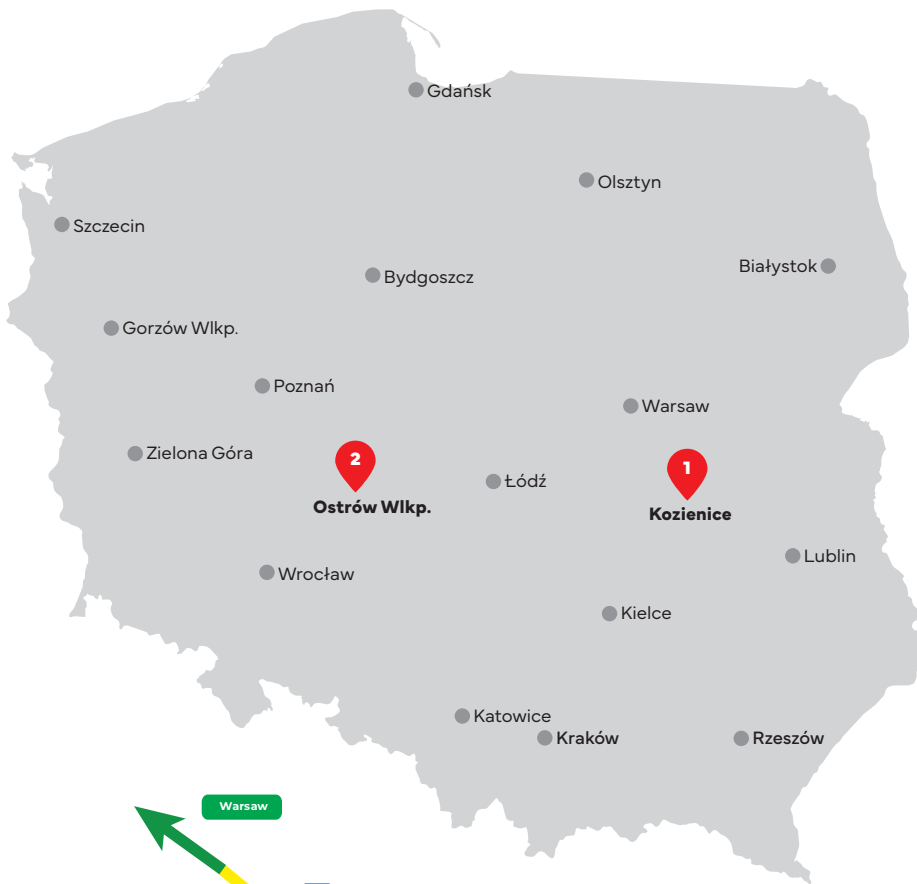

**ALPAR - HEADQUARTERS**  
Łuczynów 98  
26-900 Kozienice, Poland  
tel. +48 48 614 61 14



**ALPAR - SALES OFFICE**  
Nowa 8A  
63-400 Ostrów Wielkopolski  
tel. +48 530 906 662 | +48 530 244 868





**HEADQUARTERS:**

Łuczynów 98 | 26-900 Kozienice, Poland  
tel. +48 48 614 61 14

**SALES OFFICE:**

Nowa 8A | 63-400 Ostrów Wielkopolski, Poland  
tel. +48 530 906 662 | +48 530 244 868

**[www.alpar.pl](http://www.alpar.pl)**  
email: [sekretariat@alpar.pl](mailto:sekretariat@alpar.pl)